

Committed to Providing Quality Products
with the Best Service

Uflow[®]
Automation
INDIA

Automation
Simplified...

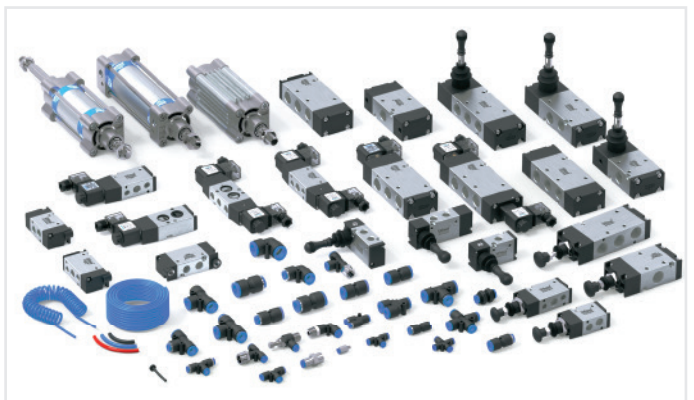

Country of Origin - INDIA



COMPANY PROFILE

Uflow Automation is an engineering organization committed to providing complete solutions to customer's requirements. We are established in the year 2007 and progressing with a vision of applying finest engineering practices in valve manufacturing industry by our restless and high skilled **ENGINEERS**, standard organizational **PROCESSES** and superior quality **PRODUCTS**.

We are a leading solenoid valve manufacturing company in India, known as **UFLOW**, our range of products includes - Pilot Operated Diaphragm Type Valves, Pneumatically Control Valves, Gas Solenoid valves, High Pressure Valves, Industrial Valves, Pneumatic Directional Control Valves, Rotary Coupling and Actuators. Our products are sold across INDIA and being exported outside India in various other countries.

Our Quality	Our Commitment	About Us
<ul style="list-style-type: none"> <input checked="" type="checkbox"/> In-House full scale testing facility. <input checked="" type="checkbox"/> Lean manufacturing practices / six sigma, kaizen, 5S. <input checked="" type="checkbox"/> Certified by : ISO 9001:2015 (TUV Nord), CE, ERDA, CIMFR, BIS, PESO. 	<ul style="list-style-type: none"> <input checked="" type="checkbox"/> To understand customer's need first before proposing our products. <input checked="" type="checkbox"/> To keep on providing competitive rate's by adapting to continuous process improvement, without compromising on quality. <input checked="" type="checkbox"/> To provide continuous support to our customers and go beyond their expectations in terms of delivery and after sale services. 	<ul style="list-style-type: none"> <input checked="" type="checkbox"/> In house R&D, manufacturing and testing facility is all located in a single premise at Rajkot Gujarat India. <input checked="" type="checkbox"/> Authorized channel partners in 20 different states in India. <input checked="" type="checkbox"/> Sales office in the UAE, Germany, Chile, Australia (Expanding).

We started building our products for a specific market segment and over the period of time we progressed to built it for various sectors that includes:

- | | | | | | |
|---|---|--|---|--|--|
| <input checked="" type="checkbox"/> Textile | <input checked="" type="checkbox"/> Water Treatment | <input checked="" type="checkbox"/> Energy & Power | <input checked="" type="checkbox"/> Packaging | <input checked="" type="checkbox"/> Pharmaceutical | <input checked="" type="checkbox"/> Oil & Gas |
| <input checked="" type="checkbox"/> Nuclear | <input checked="" type="checkbox"/> Marine | <input checked="" type="checkbox"/> Chemical | <input checked="" type="checkbox"/> Food and Beverage | <input checked="" type="checkbox"/> Steel & Cement | <input checked="" type="checkbox"/> Automotive |

We stand amongst the pioneers of the industry because of our following competitive advantages:

- Total quality management allow us to maintain the quality of our products,
- We follow genuine customer relationship policy and that help us to build trusted relationships.
- We believe in timely delivery and consistent quality standard, and this is possible due to the state of the art testing facility, that ensures our customers don't have any complains.
- Innovative products range with sophisticated and latest technology.
- Qualified customer service team, facilitate with the customers to resolve their respective query. Also feel free to ask for our customer references and product samples.

Uflow's Quality control is based on the platform of stringent process control by elimination of production variances; by a computerized integrated system we are able to guarantee the quality of products, and by recording each production step to ensure effective data analysis as well as a complete and efficient traceability of both components and finished products. This practice helps us in maintaining standards of high competitiveness in the marketplace.

Note: *For Any Other Information Contact Uflow.
* All Information may change without prior notice.

Index

Pneumatic Series	01
3/8" Manifold for 1/4" DCV Series	08
1/2" Manifold for 1/2" DCV Series	09
Pneumatic Tie Rod Cylinder (As Per ISO 15552 / VDMA 24562 Standards)	12
Pneumatic Tie Rod Cylinder (As per ISO 6431 / CETOP RP43P, RP53P standards)	14
Pneumatic Cylinder Double End Double Acting (As Per ISO 15552 / VDMA 24562 Standards)	15
Pneumatic Profile Cylinder - Square Type (As Per ISO 15552 / VDMA 24562 Standards)	17
Pneumatic Profile Cylinder Double End Double Acting - Square Type (As Per ISO 15552 / VDMA 24562 Standards)	18
Air Filter	22
Air Regulator	23
Air Lubricator	24
Filter Regulator Combination	25
FRL Modular	26
FRCL Modular	28
MIST Separator	30
High Pressure Regulator	32
One Touch Fittings	34
Flow Controller	41
Plastic Tubings	43
3/2 Single Solenoid Poppet Valve (Normally Close / Normally Open)	48
5/2 Single Solenoid Directional Control Poppet Valve (Monostable)	49
3/2 X 5/2 Convertible Single Solenoid Directional Control Namur Poppet Valve (Monostable)	50

Index

5/2 Double Solenoid Directional Control Poppet Valve (Bistable)	51
3/2 Single Solenoid Directional Control Poppet Valve (Normally Close / Normally Open)	52
3/2 Single Solenoid Namur Poppet Valve (Normally Close)	53
3 Way Direct Acting Namur Poppet Type Valve	54
3 Way Direct Acting Poppet Type Valve (Universal)	55
3 Way Direct Acting Poppet Type Valve (Universal)	56
5/2 Double Solenoid Directional Control Hybrid Poppet Valve	57
3/2 Single And Dual Pressure Blow Solenoid Poppet Valve (Normally Close)	60
Pilot Operated Diaphragm Type Solenoid Valve (Normally Close / Open)	64
Pilot Operated Diaphragm Type Solenoid Valve (Normally Close)	66
Semi Lift Diaphragm Operated Solenoid Valve (Normally Close / Open)	68
Semi Lift Diaphragm Operated Plastic Solenoid Valve (Normally Close)	70
Pilot Operated Piston Type Solenoid Valve (Normally Close / Open)	72
Pulse Jet Angle Type Dust Collector Valve (Normally Close)	74
Gas Solenoid Valve	76
2/2 Way Direct Acting Solenoid Valve (Normally Close / Open)	77
3/2 Way Direct Acting Solenoid Valve (Normally Close / Open)	80
2/2 Solenoid Valve For Terminal / Gantry Automation (Normally Close / Open)	82
2 Way Direct Acting Media Separated Solenoid Valve (normally Close)	84
2/2 Way Direct Acting Auto Drain Solenoid Valve (Normally Close)	86
Pinch Type Solenoid Valve (Normally Close / Open)	89
2/2 Way Control Valve with Aluminum Operator (Normally Close)	91

Index

Solenoid Coils	93
Angle Seat Valve with Plastic Actuator Operated (Normally Close / Open / Double Acting)	100
Angle Seat Valve with Steel Actuator Operated (Normally Closed / Open)	104
3 Way Control Valve (Normally Close / Open)	106
Rotary Quarter Turn Pneumatic Actuator	109
Screwed / Socket Weld Ball Valve	117
3 Piece Flange Ball Valve	118
Butterfly Valve	120
Micro Limit Switch	131
Roto Seal Coupling	134
External Pilot Operated Diaphragm Valve (Normally Close/Open)	138
2 Way - 3 Way Direct Acting Pilot Solenoid Valve (Normally Close/Open)	140
Pilot Operated Diaphragm Type Plastic Solenoid Valve with Flow Controller (Normally Close)	142
Proportional Flow Control Solenoid Valve - MINI (Low Flow)	145
Proportional Flow Control Solenoid Valve - MAX (High Flow)	146
3/2 Way Direct Acting Universal Valve (Normally Close / Open)	148



PNEUMATIC VALVE SERIES

Model Information

Type:	Solenoid Operated, Lever Operated, Pilot Air Operated, Push Pull (3X2-NC / NO, 5X2, 5X3)
Design:	Spool With Cartridge Type
Media:	Compressed Air (Filtered & Lubricated)
Working Pressure Range:	2 - 10 Bar for Solenoid Valve 0 - 10 Bar for Manual Valve & Air Pilot Valve
Ambient / Media Temperature:	5°C - 60°C
Materials of Construction:	Aluminium, Nitrile, Brass, Polymer

Coil Information

Coil Width :	26 mm
Coil Bore :	10 mm
Voltage (V) ± 10% :	AC (50Hz, 60Hz) - 24V, 110V, 230V DC 12V, 24V, 36V, 48V, 110V
Power Consumption :	AC-6W, DC-6W
Duty Cycle :	Continuous
Class of Insulation :	Class H
Type of Coil Protection :	IP65
Coil Housing :	Epoxy Square Coil

FEATURES

- Cartridge Type Design For Long Life
- Compact Design
- Standard NAMUR Mounting
- 1 Million Cycle Tested
- Low Power Consumption
- Manual Override
- Lubrication Not Essential
- Wide Range Of Coil Voltage

3X2, 5X2 Single solenoid valve with spring return



1 - Input, 2/4 - Output, 3/5 - Exhaust

Model No.	Flow (at 6 Bar)	Port Size			Function	Symbol
		In	Out	Exh		
SSA1BN23CT060V1	1200 LPM	¼"	¼"	¼"	Spring Return (NC)	
STA1BN23CT060V1	1200 LPM	¼"	¼"	¼"	Spring Return (NO)	
SFA1BN23CT060V1	1200 LPM	¼"	¼"	⅝"	Spring Return	
SSA2BN23CT120V0	3500 LPM	½"	½"	½"	Spring Return (NC)	
STA2BN23CT120V0	3500 LPM	½"	½"	½"	Spring Return (NO)	
SFA2BN23CT120V0	3500 LPM	½"	½"	½"	Spring Return	

3X2, 5X2 Double solenoid valve



1 - Input, 2/4 - Output, 3/5 - Exhaust

Model No.	Flow (at 6 Bar)	Port Size			Function	Symbol
		In	Out	Exh		
SVA1BN23CT060V1	1200 LPM	¼"	¼"	¼"	Double Solenoid	
SDA1BN23CT060V1	1200 LPM	¼"	¼"	⅝"	Double Solenoid	
SVA2BN23CT120V0	3500 LPM	½"	½"	½"	Double Solenoid	
SDA2BN23CT120V0	3500 LPM	½"	½"	½"	Double Solenoid	

3X2, 5X2 Single solenoid namur valve with spring return



1 - Input, 2/4 - Output, 3/5 - Exhaust

Model No.	Flow (at 6 Bar)	Port Size			Function	Symbol
		In	Out	Exh		
SCA1RN23CT060V1	1200 LPM	¼"	Namur	¼"	3X2 Spring Return	
	1200 LPM	¼"	Namur	¼"	5X2 Spring Return	

3X2, 5X2 Double solenoid namur valve

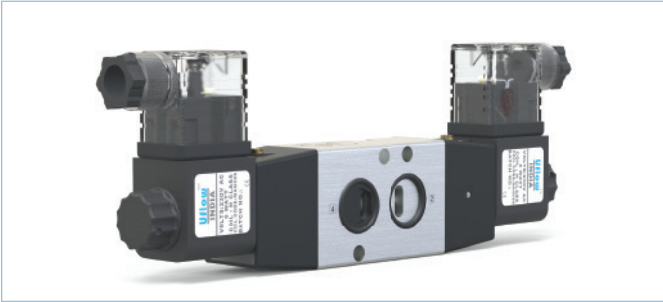

Model No.	Flow (at 6 Bar)	Port Size			Function	Symbol
		In	Out	Exh		
SJA1RN23CT060V1	1200 LPM	¼"	Namur	¼"	3X2 Double Solenoid	
	1200 LPM	¼"	Namur	¼"	5X2 Double Solenoid	

1 - Input, 2/4 - Output, 3/5 - Exhaust

5X3 Double solenoid valve with spring center



Model No.	Flow (at 6 Bar)	Port Size			Function	Symbol
		In	Out	Exh		
SBA1BN23CT060V1	1200 LPM	¼"	¼"	⅝"	Center Blocked	
SEA1BN23CT060V1	1200 LPM	¼"	¼"	⅝"	Center Exhausted	
SPA1BN23CT060V1	1200 LPM	¼"	¼"	⅝"	Center Pressurised	
SBA2BN23CT120V0	3500 LPM	½"	½"	½"	Center Blocked	
SEA2BN23CT120V0	3500 LPM	½"	½"	½"	Center Exhausted	
SPA2BN23CT120V0	3500 LPM	½"	½"	½"	Center Pressurised	

1 - Input, 2/4 - Output, 3/5 - Exhaust

3X2 Hand lever valve manual and spring return



Model No.	Flow (at 6 Bar)	Port Size			Function	Symbol
		In	Out	Exh		
LSA1BN04V1	1200 LPM	¼"	¼"	¼"	Spring Return(NC)	
LTA1BN04V1	1200 LPM	¼"	¼"	¼"	Spring Return(NO)	
LVA1BN04V1	1200 LPM	¼"	¼"	¼"	Manual Return	
LSA2BN04V0	3500 LPM	½"	½"	½"	Spring Return(NC)	
LTA2BN04V0	3500 LPM	½"	½"	½"	Spring Return(NO)	
LVA2BN04V0	3500 LPM	½"	½"	½"	Manual Return	

1 - Input, 2/4 - Output, 3/5 - Exhaust

5X2 Hand lever valve manual and spring return



Model No.	Flow (at 6 Bar)	Port Size			Function	Symbol
		In	Out	Exh		
LFA1BN04V1	1200 LPM	¼"	¼"	⅝"	Spring Return	
LDA1BN04V1	1200 LPM	¼"	¼"	⅝"	Manual Return	
LFA2BN04V0	3500 LPM	½"	½"	½"	Spring Return	
LDA2BN04V0	3500 LPM	½"	½"	½"	Manual Return	

1 - Input, 2/4 - Output, 3/5 - Exhaust

5X3 Hand lever valve manual return



1 - Input, 2/4 - Output, 3/5 - Exhaust

Model No.	Flow (at 6 Bar)	Port Size			Function	Symbol
		In	Out	Exh		
LBA1BN04V1	1200 LPM	¼"	¼"	⅝"	Center Blocked	
LEA1BN04V1	1200 LPM	¼"	¼"	⅝"	Center Exhausted	
LPA1BN04V1	1200 LPM	¼"	¼"	⅝"	Center Pressurised	
LBA2BN04V0	3500 LPM	½"	½"	½"	Center Blocked	
LEA2BN04V0	3500 LPM	½"	½"	½"	Center Exhausted	
LPA2BN04V0	3500 LPM	½"	½"	½"	Center Pressurised	

5X3 Hand lever valve with spring center



1 - Input, 2/4 - Output, 3/5 - Exhaust

Model No.	Flow (at 6 Bar)	Port Size			Function	Symbol
		In	Out	Exh		
LKA1BN04V1	1200 LPM	¼"	¼"	⅝"	Center Blocked	
LHA1BN04V1	1200 LPM	¼"	¼"	⅝"	Center Exhausted	
LRA1BN04V1	1200 LPM	¼"	¼"	⅝"	Center Pressurised	
LKA2BN04V0	3500 LPM	½"	½"	½"	Center Blocked	
LHA2BN04V0	3500 LPM	½"	½"	½"	Center Exhausted	
LRA2BN04V0	3500 LPM	½"	½"	½"	Center Pressurised	

3X2 External pilot operated valve



1 - Input, 2/4 - Output, 3/5 - Exhaust, 10/12 - External Pilot

Model No.	Flow (at 6 Bar)	Port Size			Function	Symbol
		In	Out	Exh		
ASA1BN04V1	1200 LPM	¼"	¼"	¼"	Spring Return(NC)	
ATA1BN04V1	1200 LPM	¼"	¼"	¼"	Spring Return(NO)	
AVA1BN04V1	1200 LPM	¼"	¼"	¼"	Double External	
ASA2BN04V0	3500 LPM	½"	½"	½"	Spring Return(NC)	
ATA2BN04V0	3500 LPM	½"	½"	½"	Spring Return(NO)	
AVA2BN04V0	3500 LPM	½"	½"	½"	Double External	

5X2 External pilot operated valve

1 - Input, 2/4 - Output, 3/5 - Exhaust, 10/12 - External Pilot



Model No.	Flow (at 6 Bar)	Port Size			Function	Symbol
		In	Out	Exh		
AFA1BN04V1	1200 LPM	¼"	¼"	⅙"	Spring Return	
ADA1BN04V1	1200 LPM	¼"	¼"	⅙"	Double External	
AFA2BN04V0	3500 LPM	½"	½"	½"	Spring Return	
ADA2BN04V0	3500 LPM	½"	½"	½"	Double External	

5X3 Double external pilot operated valve with spring center

1 - Input, 2/4 - Output, 3/5 - Exhaust, 10/12 - External Pilot



Model No.	Flow (at 6 Bar)	Port Size			Function	Symbol
		In	Out	Exh		
AKA1BN04V1	1200 LPM	¼"	¼"	⅙"	Center Blocked	
AHA1BN04V1	1200 LPM	¼"	¼"	⅙"	Center Exhausted	
ARA1BN04V1	1200 LPM	¼"	¼"	⅙"	Center Pressurised	
AKA2BN04V0	3500 LPM	½"	½"	½"	Center Blocked	
AHA2BN04V0	3500 LPM	½"	½"	½"	Center Exhausted	
ARA2BN04V0	3500 LPM	½"	½"	½"	Center Pressurised	

3X2 Push pull valve manual and spring return

1 - Input, 2/4 - Output, 3/5 - Exhaust



Model No.	Flow (at 6 Bar)	Port Size			Function	Symbol
		In	Out	Exh		
PSA1BN04V1	1200 LPM	¼"	¼"	¼"	Spring Return(NC)	
PTA1BN04V1	1200 LPM	¼"	¼"	¼"	Spring Return(NO)	
PVA1BN04V1	1200 LPM	¼"	¼"	¼"	Manual Return	
PSA2BN04V0	3500 LPM	½"	½"	½"	Spring Return(NC)	
PTA2BN04V0	3500 LPM	½"	½"	½"	Spring Return(NO)	
PVA2BN04V0	3500 LPM	½"	½"	½"	Manual Return	

5X2 Push pull valve manual and spring return

1 - Input, 2/4 - Output, 3/5 - Exhaust



Model No.	Flow (at 6 Bar)	Port Size			Function	Symbol
		In	Out	Exh		
PFA1BN04V1	1200 LPM	¼"	¼"	⅙"	Spring Return	
PDA1BN04V1	1200 LPM	¼"	¼"	⅙"	Manual Return	
PFA2BN04V0	3500 LPM	½"	½"	½"	Spring Return	
PDA2BN04V0	3500 LPM	½"	½"	½"	Manual Return	

DC SOLENOID VALVE MODEL IDENTIFICATION CHART

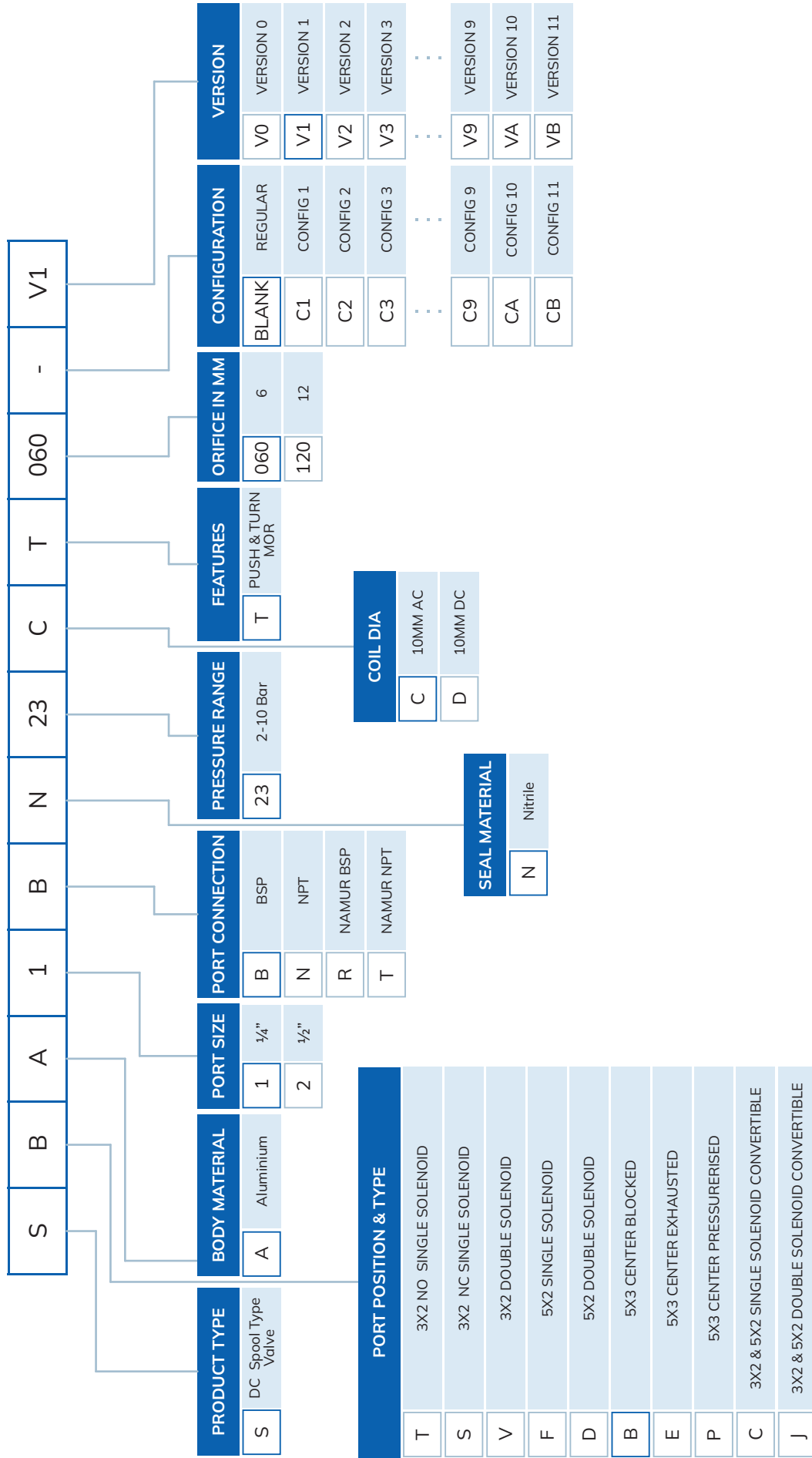

SBA1BN23CT060V1

1/4" 5X3 CENTER BLOCKED DC SPOOL TYPE VALVE ALUMINIUM-BSP-NITRILE-2 TO 10 Bar-10MM AC-PUSH & TURN MOR-6MM ORIFICE-VERSION 1

DC MANUAL MODEL IDENTIFICATION CHART

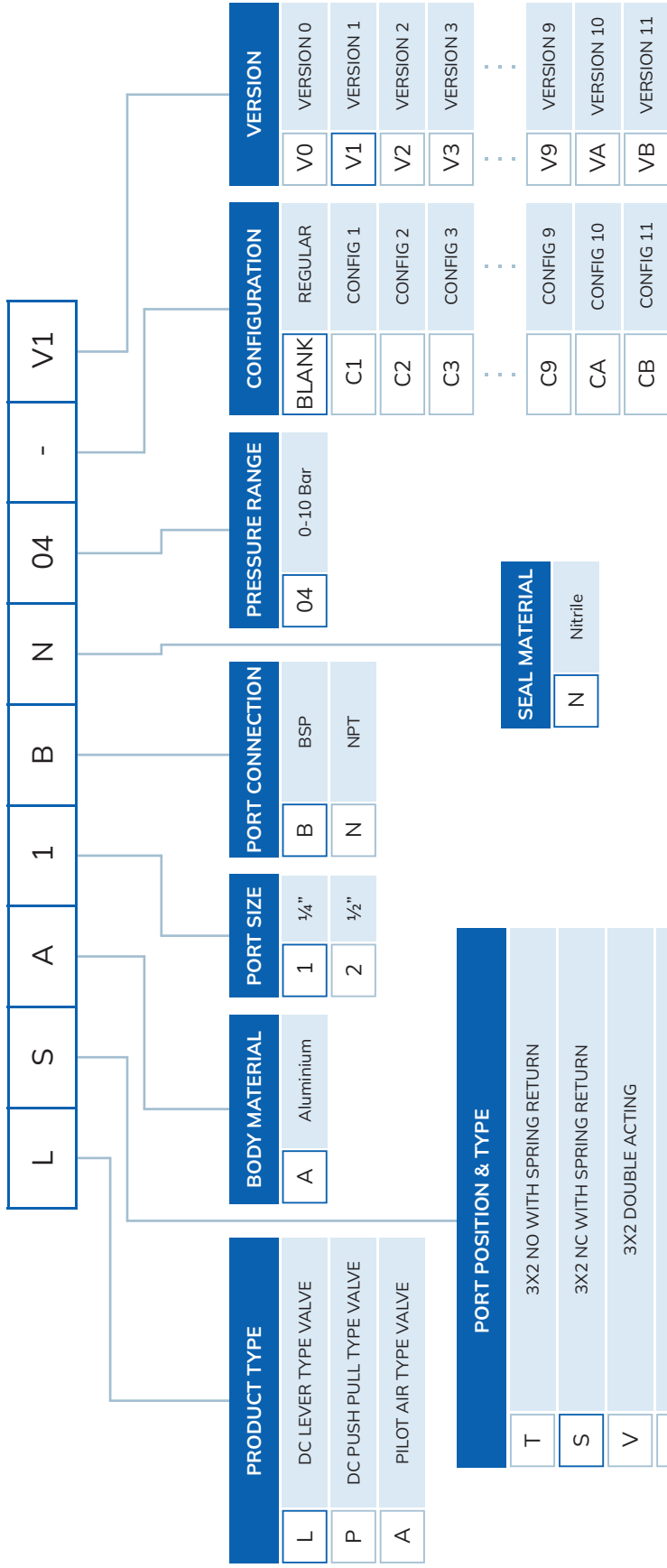

LSA1BN04V1

1/4" 3X2 NC WITH SPRING RETURN DC LEVER TYPE VALVE ALUMINIUM-BSP-NITRILE-0 TO 10 Bar-VERSION 1

Technical Data for 3X2 Manifold

Model No.	Diagram No.	No. of Valve	A
NTA102V0	19.1	02	81
NTA103V0	19.1	03	108
NTA104V0	19.1	04	135
NTA105V0	19.1	05	162
NTA106V0	19.1	06	189
NTA107V0	19.1	07	216
NTA108V0	19.1	08	243
NTA109V0	19.1	09	270
NTA110V0	19.1	10	297

Technical Data for 5X2 Manifold

Model No.	Diagram No.	No. of Valve	A
NFA102V0	19.2	02	81
NFA103V0	19.2	03	108
NFA104V0	19.2	04	135
NFA105V0	19.2	05	162
NFA106V0	19.2	06	189
NFA107V0	19.2	07	216
NFA108V0	19.2	08	243
NFA109V0	19.2	09	270
NFA110V0	19.2	10	297

FEATURES

- Ease of maintenance.
- Inlet & Exhaust on the manifold.
- Blanking plate can be installed or removed as per need according to future requirements, in case customer wish to add on extra valve.

DIAGRAM NO.19.1 - DIMENSIONS (MM)

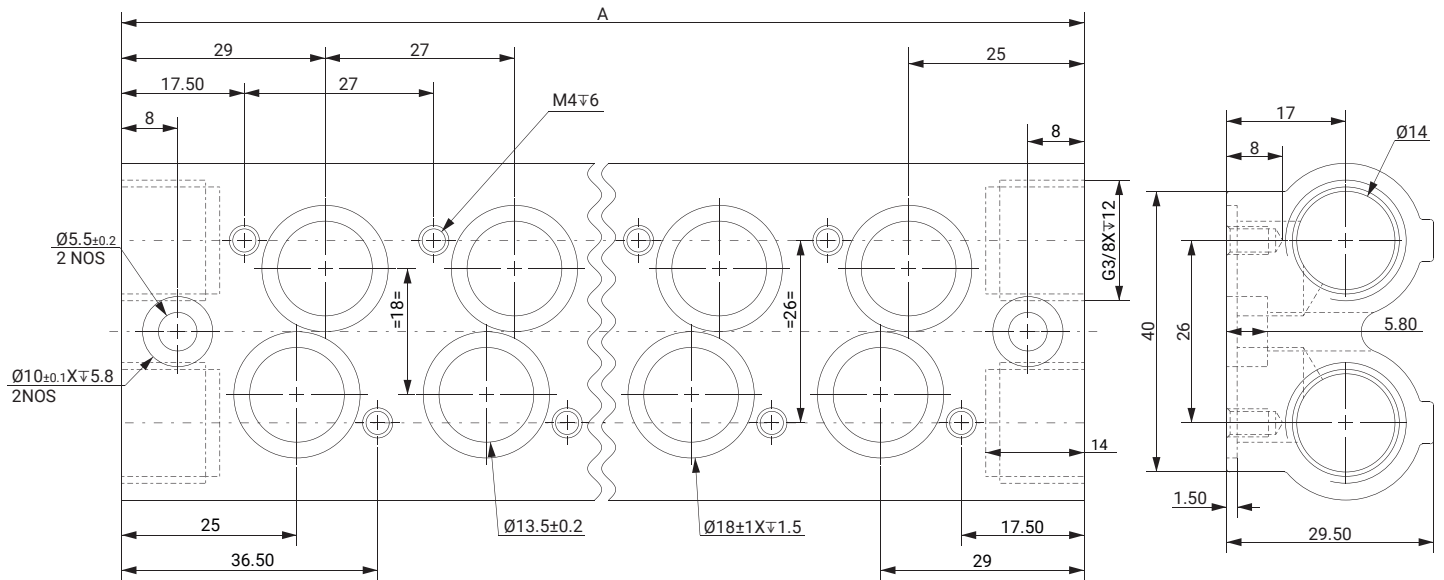
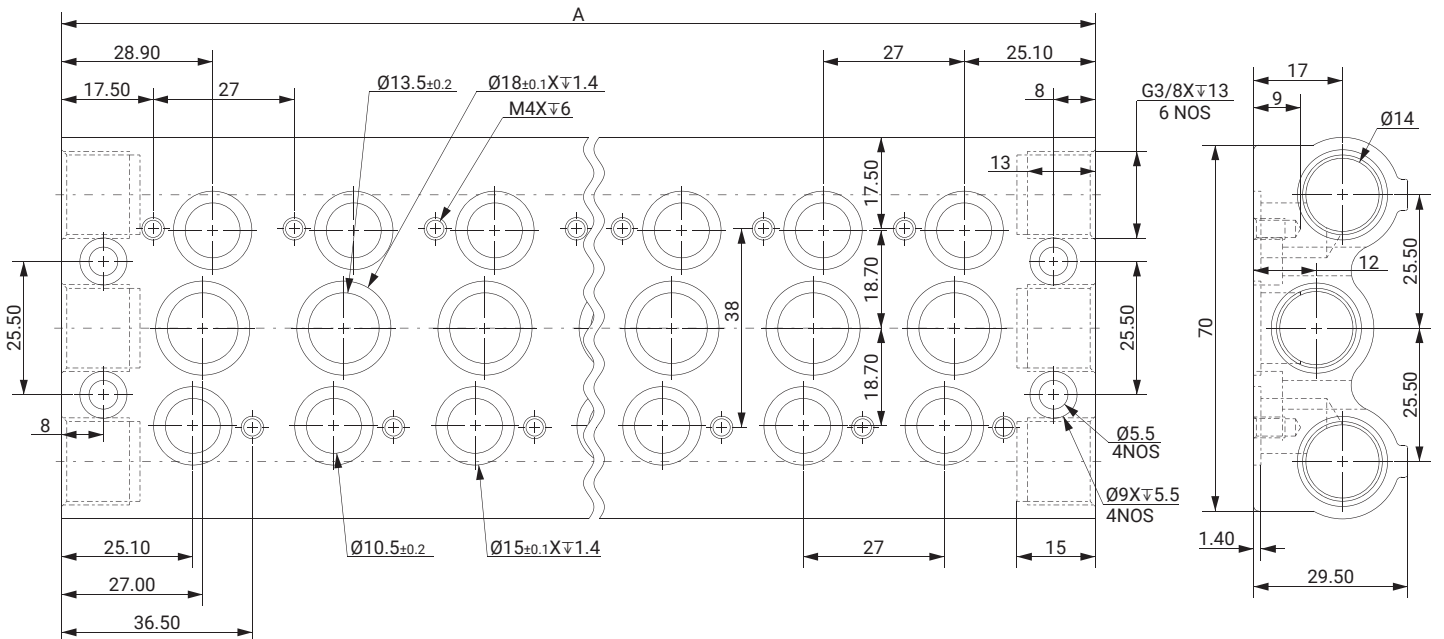

DIAGRAM NO.19.2 - DIMENSIONS (MM)



Technical Data for 3X2 Manifold

Model No.	Diagram No.	No. of Valve	A
NTA202V0	20.1	02	102
NTA203V0	20.1	03	138
NTA204V0	20.1	04	174
NTA205V0	20.1	05	210
NTA206V0	20.1	06	246
NTA207V0	20.1	07	282
NTA208V0	20.1	08	318
NTA209V0	20.1	09	354
NTA210V0	20.1	10	390

Technical Data for 5X2 Manifold

Model No.	Diagram No.	No. of Valve	A
NFA202V0	20.2	02	102
NFA203V0	20.2	03	138
NFA204V0	20.2	04	174
NFA205V0	20.2	05	210
NFA206V0	20.2	06	246
NFA207V0	20.2	07	282
NFA208V0	20.2	08	318
NFA209V0	20.2	09	354
NFA210V0	20.2	10	390

FEATURES

- Ease of maintenance.
- Inlet & Exhaust on the manifold.
- Blanking plate can be installed or removed as per need according to future requirements, in case customer wish to add on extra valve.

DIAGRAM NO. 20.1 - DIMENSIONS (MM)

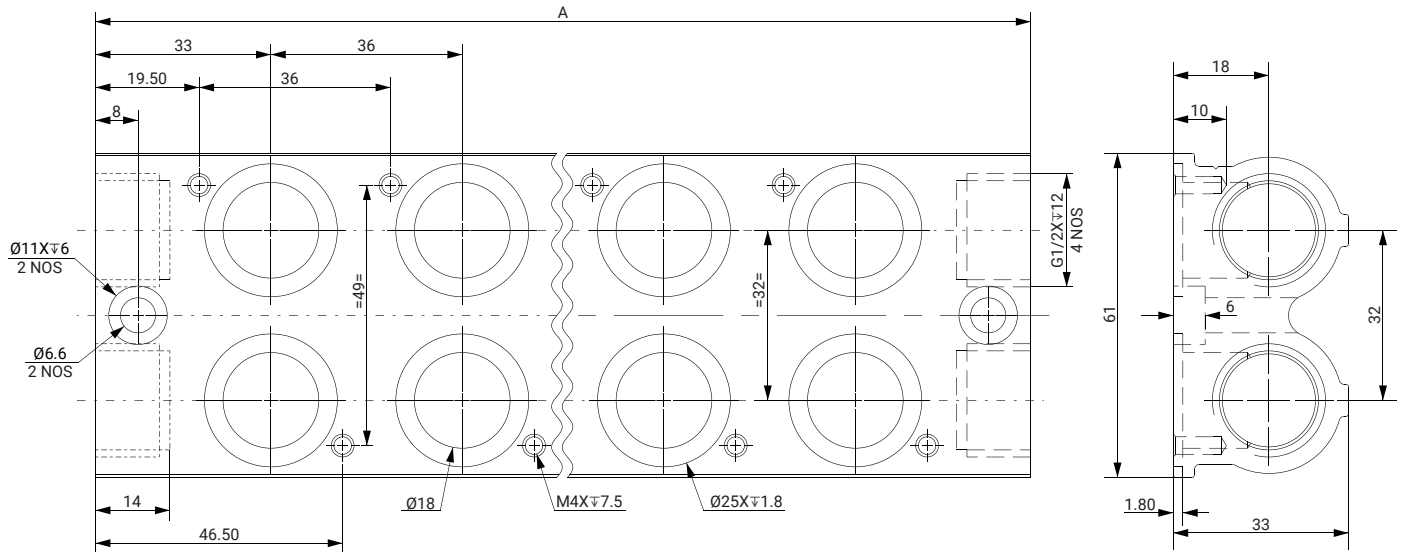
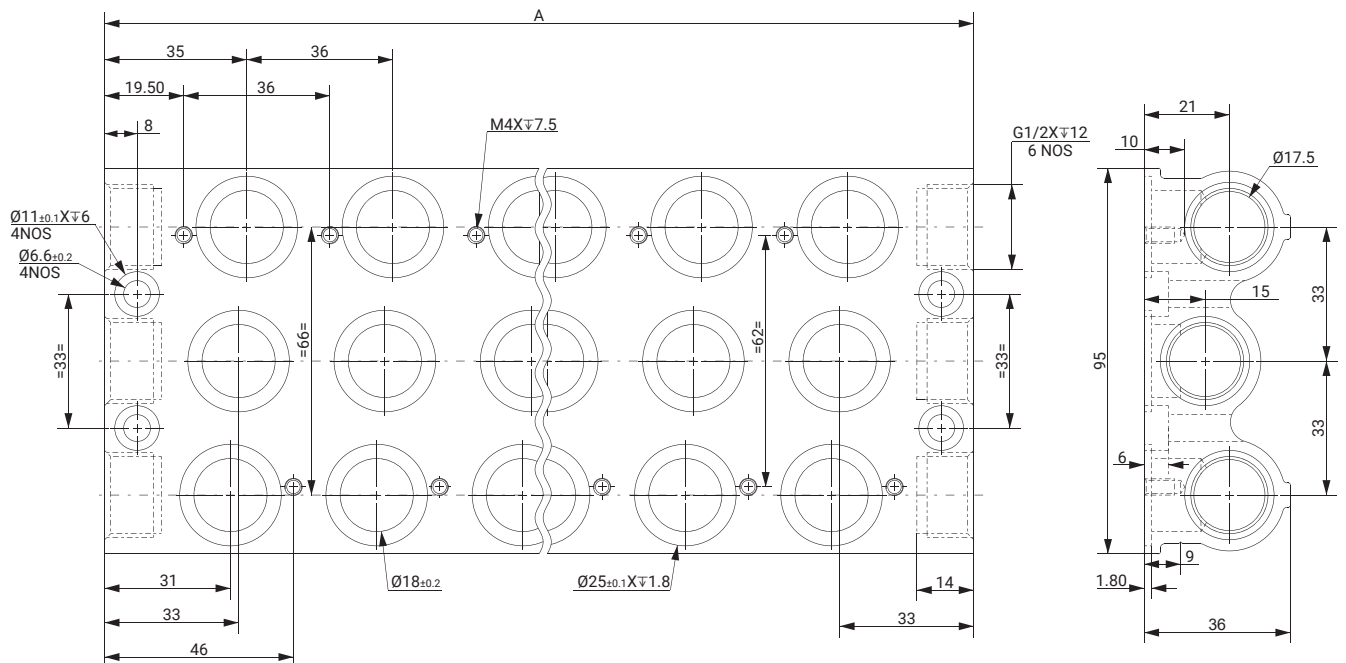
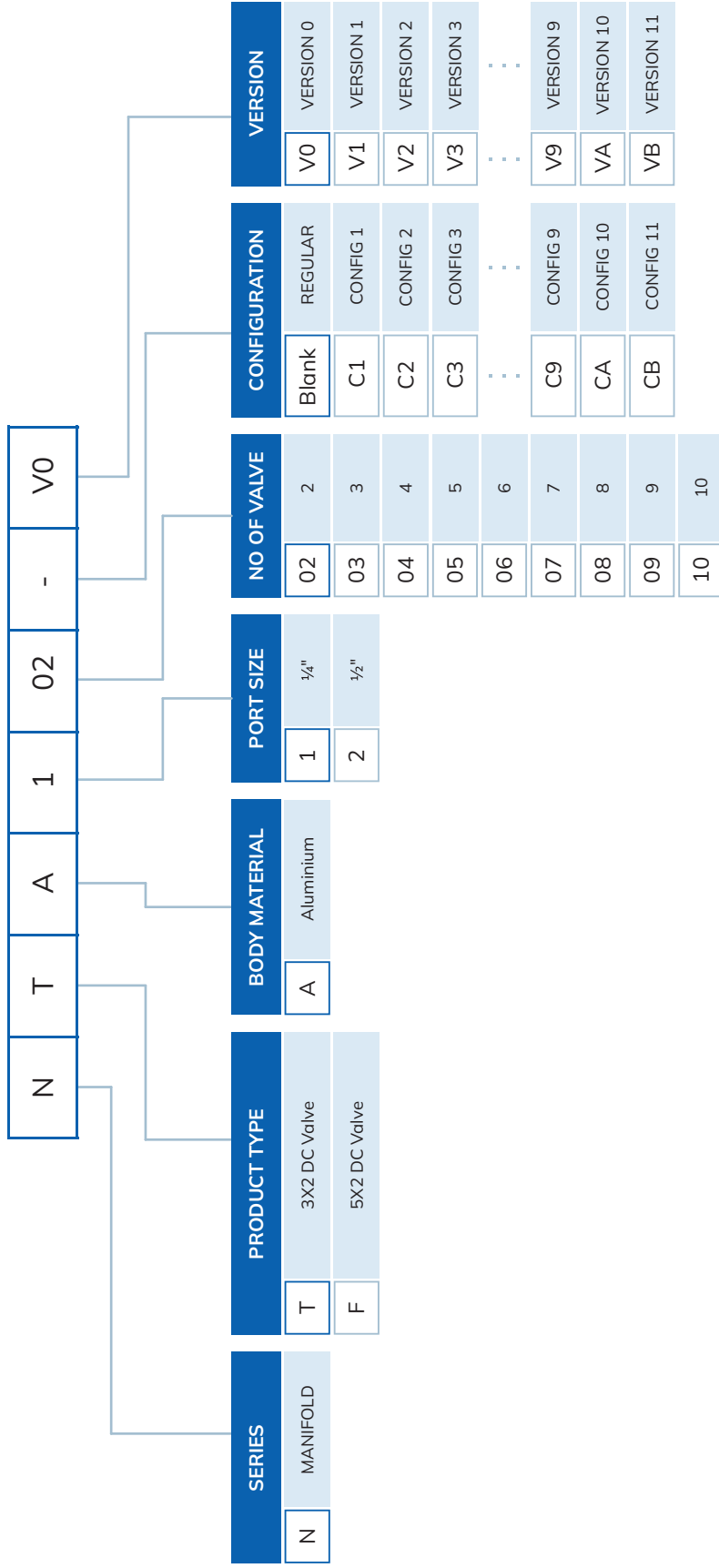

DIAGRAM NO. 20.2 - DIMENSIONS (MM)



MANIFOLD VALVE MODEL IDENTIFICATION CHART



NTA102V0
1/4" MANIFOLD ALUMINIUM 2 NOS OF 3X2 DIRECTIONAL CONTROL VALVE



PNEUMATIC AIR CYLINDER SERIES

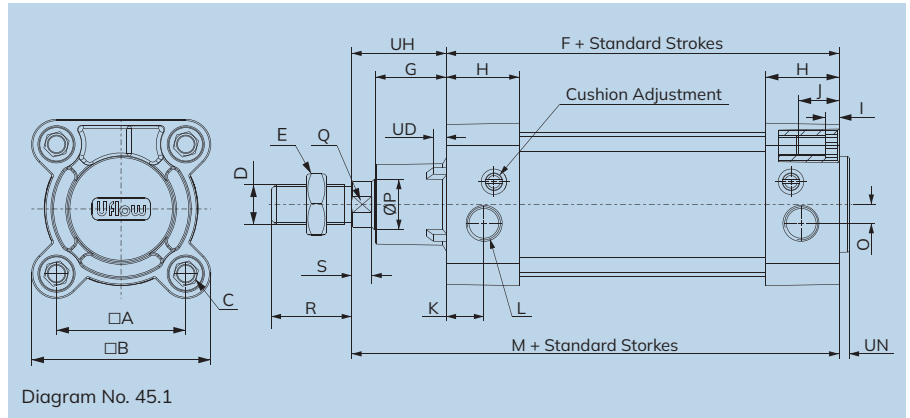

Specifications

Cylinder bore Ø (mm) :	32	40	50	63	80	100	125	160	200	250
Cushion stroke (mm) :	21	23	23	23	28	28	40	40	40	50
Standard strokes (mm):	25, 50, 80, 100, 125, 160, 200, 250, 300, 320, 400, 500									
Media :	Compressed air - filtered - lubricated									
Working pressure :	0.5 - 10 bar									
Medium temperature :	Regular +5°C to +60°C		High temperature applications +5°C to +150°C Max							
Materials of Construction :	Aluminium, Brass, Steel, Acetal, Polyurethane, Nitrile (Regular), FKM (High temperature)									
Mountings :	Foot Mounting, Front Flange, Rear Flange, Male Clevis, Female Clevis, Female Clevis (king Pin), Center Trunnion, Front Trunnion , Rear Trunnion									
Accessories :	Clevis Foot Bracket, Wall Mounting Bracket, Trunnion Bracket, Rod End Fork, Rod End Aligner, Rod End Spherical Eye									

Features

- Adjustable cushioning at both ends with elastomer pads.
- Wide varieties of mountings.
- Optional - High temperature (Viton seals) 150°C max.
- Optional - Non corrosive stainless steel piston rod and piston rod lock nut (SS304)

Technical Data

All Dimension in mm

Cylinder bore Ø	A	B	C	D	E	F +TOL	G	H	I	J	K	L	M +TOL	UN	O	P	Q	R	S	ØT	UD	UH + TOL	Stroke tol			
32	32.5	45	M6	M10X1.25	17	94 ±0.6	18.5	25.5	5	16	13	G $\frac{1}{8}$	120	±1	4	5	12	10	22	6	30	6	26	+2		
40	38	51	M6	M12X1.25	19	105	20.5	29	5	16	14.5	G $\frac{1}{4}$	135	±1	4	5	16	13	24	6.5	35	6.5	30	±1.3	+0	
50	46.5	64	M8	M16X1.5	24	106	±0.7	28	29	6	16	15	G $\frac{1}{4}$	143	±1.1	4	7.5	20	16	32	8	40	6.5	37	+2.5	
63	56.5	74	M8	M16X1.5	24	121	±0.8	27.5	35	6	16	17	G $\frac{3}{8}$	158	±1.1	4	10	20	16	32	8	45	6.5	37	+0	
80	72	94	M10	M20X1.5	30	128	±0.8	34	35	6	16	18	G $\frac{3}{8}$	174	±1.1	4	14	25	21	40	10	45	6.5	46	±1.5	+0
100	89	111	M10	M20X1.5	30	138	±1.0	35	38.5	6	16	18	G $\frac{1}{2}$	189	±1.2	4	10	25	21	40	10	55	6.5	51	+0	
125	110	136	M12	M27X2	41	160	±1.0	46.5	44	-	20	20	G $\frac{1}{2}$	225	±1.2	6	12	32	27	54	10	60	10	65	+4	
160	140	183	M16	M36X2	55	180	±1.1	60	50.7	-	24	31	G $\frac{3}{4}$	260	±1.5	6	12	40	36	72	8	65	8	60	±2.2	+0
200	175	222	M16	M36X2	55	180	±1.6	70	46.7	-	24	30	G $\frac{3}{4}$	275	±1.5	6	12	40	36	72	8	75	8	95	+0	
250	220	272	M20	M42X2	65	200	±1.6	75	51.2	-	25	32	G1	305	±2	10	25	50	46	84	12	90	12	105	+5	

Output Force

(Force in N : 1N = 0.1 kgf)

Cylinder bore Ø (mm)	Rod Ø (mm)		Working pressure in bar								
			2	3	4	5	6	7	8	9	10
32	12	Extend	145	217	289	362	434	507	579	651	724
		Retract	124	187	249	311	373	435	498	559	621
40	16	Extend	226	339	452	565	678	792	905	1018	1130
		Retract	190	285	380	475	570	665	760	855	950
50	20	Extend	353	530	706	884	1060	1237	1414	1590	1767
		Retract	297	445	594	742	891	1039	1187	1336	1484
63	20	Extend	561	842	1122	1403	1683	1964	2244	2525	2805
		Retract	505	757	1009	1261	1514	1766	2018	2270	2523
80	25	Extend	905	1357	1809	2262	2714	3167	3619	4072	4524
		Retract	816	1225	1633	2041	2449	2857	3266	3674	4082
100	25	Extend	1414	2120	2828	3534	4241	4948	5655	6362	7069
		Retract	1325	1988	2650	3313	3976	4640	5300	5965	6625
125	32	Extend	2209	3313	4417	5522	6626	7731	8835	9940	11044
		Retract	2064	3096	4128	5160	6192	7224	8256	9288	10320
160	40	Extend	3619	5428	7238	9047	10857	12666	14476	16286	18095
		Retract	3392	5089	6785	8482	10178	11875	13571	15268	16964
200	40	Extend	5654	8482	11309	14137	16964	19792	22619	25446	28274
		Retract	5428	8143	10857	13571	16286	19000	21714	24429	27143
250	50	Extend	8836	13253	17671	22089	26507	30925	35343	39760	44178
		Retract	8482	12723	16964	21205	25446	29688	33929	38170	42411

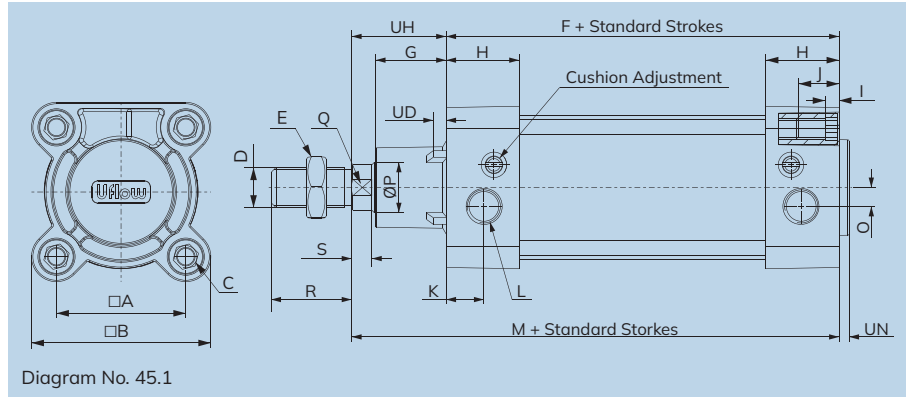

Specifications

Cylinder bore Ø (mm) :	32	40	50	63	80	100
Cushion stroke (mm) :	21	23	23	23	28	28
Standard strokes (mm):	25, 50, 80, 100, 125, 160, 200, 250, 300, 320, 400, 500					
Media :	Compressed air - filtered - lubricated					
Working pressure :	0.5 - 10 bar					
Medium temperature :	Regular +5°C to +60°C		High temperature applications +5°C to +150°C Max			
Materials of Construction :	Aluminium, Brass, Steel, Acetal, Polyurethane, Nitrile (Regular), FKM (High temperature)					
Mountings	Foot Mounting, Front Flange, Rear Flange, Male Clevis, Female Clevis, Female Clevis (king Pin), Center Trunnion, Front Trunnion, Rear Trunnion					
Accessories	Clevis Foot Bracket, Wall Mounting Bracket, Trunnion Bracket, Rod End Fork, Rod End Aligner, Rod End Spherical Eye					

Features

- Adjustable cushioning at both ends with elastomer pads.
- Wide varieties of mountings.
- Optional - High temperature (Viton seals) 150°C max.
- Optional - Non corrosive stainless steel piston rod and piston rod lock nut (SS304)

Technical Data

All Dimension in mm

Cylinder bore Ø	A	B	C	D	E	F + TOL	G	H	I	J	K	L	M + TOL	UN	O	P	Q	R	S	ØT	UD	UH + TOL	Stroke tol		
32	32	44	M6	M10X1.25	17	94		20.5	25	5	16	8.5	G $\frac{3}{4}$	120	4	0	12	10	22	6	30	6	26		
40	40	55	M6	M12X1.25	19	105	±0.6	24.5	28	5	16	12	G $\frac{3}{4}$	135	4	3	16	13	24	6.5	35	6.5	30	+1.3	+2
50	48	63	M8	M16X1.5	24	106	±0.7	30	30	6	16	12	G $\frac{3}{4}$	143	4	5	20	16	32	8	40	6.5	37		
63	60	83	M8	M16X1.5	24	121		30.5	33	6	16	16.5	G $\frac{3}{4}$	158	4	10	20	16	32	8	45	6.5	37		
80	72	98	M10	M20X1.5	30	128	±0.8	38.5	33	6	16	16	G $\frac{3}{4}$	174	4	15	25	21	40	10	45	6.5	46	+1.5	+2.5
100	89	115	M10	M20X1.5	30	138		44	37	6	16	18	G $\frac{1}{2}$	189	4	15	25	21	40	10	55	6.5	51		

Output Force

(Force in N : 1N = 0.1 kgf)

Cylinder bore Ø (mm)	Rod Ø (mm)		Working pressure in bar									
			2	3	4	5	6	7	8	9	10	
32	12	Extend	145	217	289	362	434	507	579	651	724	
		Retract	124	187	249	311	373	435	498	559	621	
40	16	Extend	226	339	452	565	678	792	905	1018	1130	
		Retract	190	285	380	475	570	665	760	855	950	
50	20	Extend	353	530	706	884	1060	1237	1414	1590	1767	
		Retract	297	445	594	742	891	1039	1187	1336	1484	
63	20	Extend	561	842	1122	1403	1683	1964	2244	2525	2805	
		Retract	505	757	1009	1261	1514	1766	2018	2270	2523	
80	25	Extend	905	1357	1809	2262	2714	3167	3619	4072	4524	
		Retract	816	1225	1633	2041	2449	2857	3266	3674	4082	
100	25	Extend	1414	2120	2828	3534	4241	4948	5655	6362	7069	
		Retract	1325	1988	2650	3313	3976	4640	5300	5965	6625	

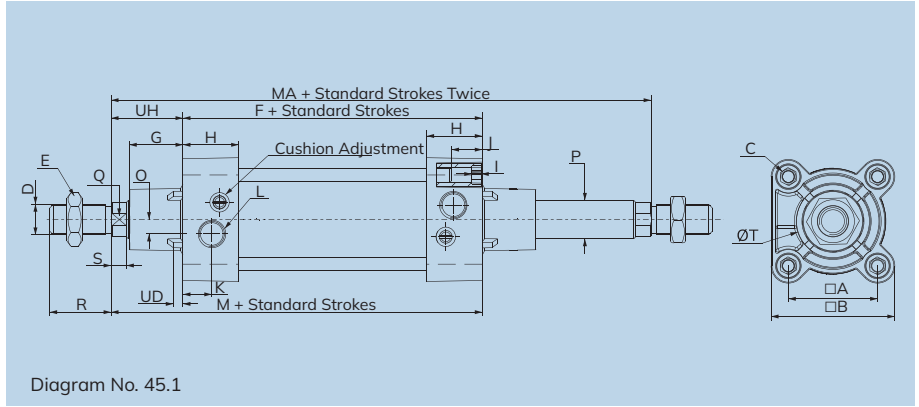

Specifications

Cylinder Bore Ø (mm) :	32	40	50	63	80	100	125	160	200
Cushion Stroke (mm) :	21	23	23	23	28	28	40	40	40
Standard Strokes (mm):	25, 50, 80, 100, 125, 160, 200, 250, 300, 320, 400, 500								
Media :	Compressed air - filtered - lubricated								
Working Pressure :	0.5 - 10 bar								
Medium Temperature :	Regular +5°C to +60°C		High Temperature Applications +5°C to +150°C Max						
Materials of Construction :	Aluminium, Brass, Steel, Acetal, Polyurethane, Nitrile (Regular), FKM (High temperature)								
Mountings	Foot Mounting, Flange, Female Clevis, Front Trunnion, Center Trunnion								
Accessories	Clevis Foot Bracket, Wall Mounting Bracket, Trunnion Bracket, Rod End Fork, Rod End Aligner, Rod End Spherical Eye								

Features

- Adjustable cushioning at both ends with pads.
- Wide varieties of mountings.
- Optional - High temperature (Viton seals) 150°C max.
- Optional - Non corrosive stainless steel piston rod and piston rod lock nut (SS304)

Technical Data

Cylinder bore Ø	All Dimension in mm																							Stroke tol			
	A	B	C	D	E	F +TOL	G	H	I	J	K	L	M +TOL	MA +TOL	O	P	Q	R	S	ØT	UD	UH +TOL					
32	32.5	45	M6	M10X1.25	17	94	±0.6	18.5	25.5	5	16	13	G½	120	±1	147	5	12	10	22	6	30	6	26			
40	38	51	M6	M12X1.25	19	105		20.5	29	5	16	14.5	G¼	135		166										7.5	16
50	46.5	64	M8	M16X1.5	24	106	±0.7	28	29	6	16	15	G¼	143	±1.5	181	10	20	16	32	8	40	6.5	37			
63	56.5	74	M8	M16X1.5	24	121	27.5	35	6	16	17	G¾	158	196		14										20	16
80	72	94	M10	M20X1.5	30	128	±0.8	34	35	6	16	18	G¾	174	±1.1	221	14	25	21	40	10	45	6.5	46	±1.5	0	
100	89	111	M10	M20X1.5	30	138	35	38.5	6	16	18	G½	189	241		10											25
125	110	136	M12	M27X2	41	160	±1	48.5	44	6	20	20	G½	225	±1.2	292	12	32	27	54	13	60	10	66			
160	140	183	M18	M36X2	55	180	±1.1	60	51	-	24	26	G¾	260	±1.5	341										±2	12
200	175	222	M16	M36X2	55	180	±1.6	70	46	-	24	25	G¾	275	±1.5	372	25	40	36	72	16	75	8	96			

Output Force

(Force in N : 1N = 0.1 kgf)

Cylinder bore Ø (mm)	Rod Ø (mm)	Working pressure in bar									
		2	3	4	5	6	7	8	9	10	
32	12	124	187	249	311	373	435	498	559	621	
40	16	190	285	380	475	570	665	760	855	950	
50	20	297	445	594	742	891	1039	1187	1336	1484	
63	20	505	757	1009	1261	1514	1766	2018	2270	2523	
80	25	816	1225	1633	2041	2449	2857	3266	3674	4082	
100	25	1325	1988	2650	3313	3976	4640	5300	5965	6625	
125	32	2064	3096	4128	5160	6192	7224	8256	9288	10320	
160	40	3392	5089	6785	8482	10178	11875	13571	15268	16964	
200	40	5428	8143	10857	13571	16286	19000	21714	24429	27143	

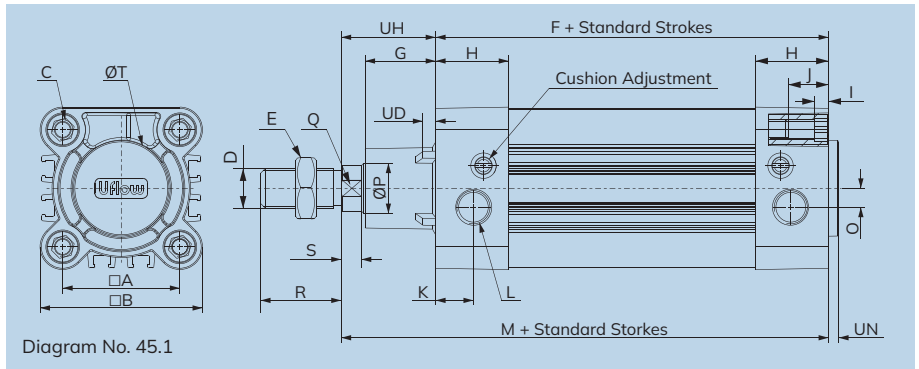

Diagram No. 45.1

Specifications

Cylinder Bore Ø (mm) :	32	40	50	63	80	100	125
Cushion Stroke (mm) :	21	23	23	23	28	28	40
Standard Strokes (mm):	25, 50, 80, 100, 125, 160, 200, 250, 300, 320, 400, 500						50, 80, 100, 125, 160, 200
Media :	Compressed air - filtered - lubricated						250, 300, 320, 400, 500
Working Pressure :	0.5 - 10 bar						
Medium Temperature :	Regular			High temperature applications			
	5°C - 60°C			5°C - 150°C Max			
Materials of Construction :	Aluminium, Brass, Steel, Acetal, Polyurethane, Nitrile (Regular), FKM (High temperature)						
Mountings :	Foot Mounting, Front Flange, Rear Flange, Male Clevis, Male Clevis (with Spherical Bearing), Female Clevis, Female Clevis (king Pin), Front Trunnion, Rear Trunnion						
Accessories :	Clevis Foot Bracket, Clevis Foot Bracket (spherical), Wall Mounting Bracket, Trunnion Bracket, Rod End Fork, Rod End Aligner, Rod End Spherical Eye						

Features

- Adjustable cushioning at both ends with pads.
- Wide varieties of mountings.
- Optional - High temperature (Viton seals) 150°C max.
- Optional - Non corrosive stainless steel piston rod and piston rod lock nut (SS304)

Technical Data

All Dimension in mm

Cylinder bore Ø	A	B	C	D	E	F + TOL	G	H	I	J	K	L	M + TOL	UN	O	P	Q	R	S	ØT	UD	UH + TOL	Stroke tol			
32	32.5	45	M6	M10X1.25	17	94		18.5	25.5	5	16	13	G½	120		4	5	12	10	22	6	30	6	26		
40	38	51	M6	M12X1.25	19	105	±0.6	20.5	29	5	16	14.5	G¾	135	±1	4	5	16	13	24	6.5	35	6.5	30	±1.3	+2
50	46.5	64	M8	M16X1.5	24	106	±0.7	28	29	6	16	15	G¾	143		4	7.5	20	16	32	8	40	6.5	37	+0	
63	56.5	74	M8	M16X1.5	24	121		27.5	35	6	16	17	G¾	158		4	10	20	16	32	8	45	6.5	37	+2.5	
80	72	94	M10	M20X1.5	30	128	±0.8	34	35	6	16	18	G¾	174	±1.1	4	14	25	21	40	10	45	6.5	46	±1.5	+0
100	89	111	M10	M20X1.5	30	138		35	38.5	6	16	18	G½	189		4	10	25	21	40	10	55	6.5	51	+0	
125	110	136	M12	M20X1.5	41	160	±1	49	44	-	20	20	G½	225	±1.2	6	12	32	27	54	13	60	10	5	±2.2	+4

Output Force

(Force in N : 1N = 0.1 kgf)

Cylinder bore Ø (mm)	Rod Ø (mm)		Working pressure in bar									
			2	3	4	5	6	7	8	9	10	
32	12	Extend	145	217	289	362	434	507	579	651	724	
		Retract	124	187	249	311	373	435	498	559	621	
40	16	Extend	226	339	452	565	678	792	905	1018	1130	
		Retract	190	285	380	475	570	665	760	855	950	
50	20	Extend	353	530	706	884	1060	1237	1414	1590	1767	
		Retract	297	445	594	742	891	1039	1187	1336	1484	
63	20	Extend	561	842	1122	1403	1683	1964	2244	2525	2805	
		Retract	505	757	1009	1261	1514	1766	2018	2270	2523	
80	25	Extend	905	1357	1809	2262	2714	3167	3619	4072	4524	
		Retract	816	1225	1633	2041	2449	2857	3266	3674	4082	
100	25	Extend	1414	2120	2828	3534	4241	4948	5655	6362	7069	
		Retract	1325	1988	2650	3313	3976	4640	5300	5965	6625	
125	32	Extend	2209	3313	4417	5522	6626	7731	8835	9940	11044	
		Retract	2064	3096	4128	5160	6192	7224	8256	9288	10320	

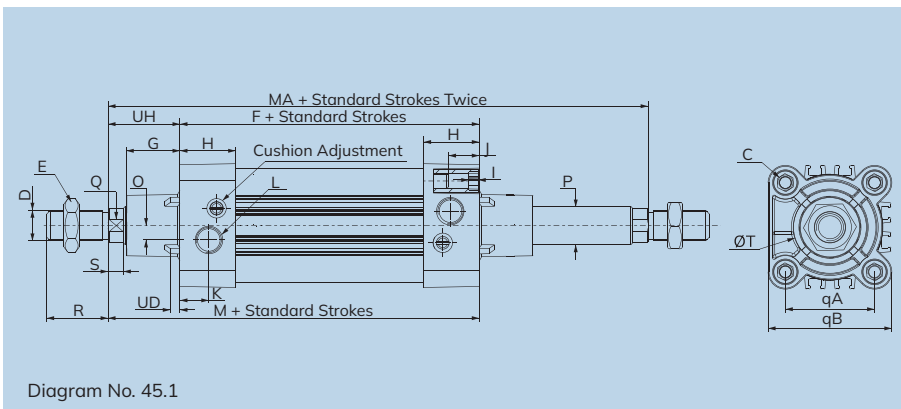

Specifications

Cylinder Bore Ø (mm) :	32	40	50	63	80	100	125
Cushion Stroke (mm) :	21	23	23	23	28	28	40
Standard Strokes (mm):	25, 50, 80, 100, 125, 160, 200, 250, 300, 320, 400, 500			50, 80, 100, 125, 160, 200, 250, 300, 320, 400, 500			
Media :	Compressed air - filtered - lubricated						
Working Pressure :	0.5 - 10 bar						
Medium Temperature :	Regular +5°C to +60°C		High Temperature Applications +5°C to +150°C Max				
Materials of Construction :	Aluminium, Brass, Steel, Acetal, Polyurethane, Nitrile (Regular), FKM (High temperature)						
Mountings	Foot Mounting, Flange, Female Clevis, Front & Rear Trunnion, Center Trunnion						
Accessories	Clevis Foot Bracket, Wall Mounting Bracket, Trunnion Bracket, Rod End Fork, Rod End Aligner, Rod End Spherical Eye						

Features

- Adjustable cushioning at both ends with pads.
- Wide varieties of mountings.
- Optional - High temperature (Viton seals) 150°C max.
- Optional - Non corrosive stainless steel piston rod and piston rod lock nut (SS304)

Technical Data

All Dimension in mm

Cylinder bore Ø	A	B	C	D	E	F +TOL	G	H	I	J	K	L	M +TOL	MA +TOL	O	P	Q	R	S	ØT	UD	UH +TOL	Stroke tol				
32	32.5	45	M6	M10X1.25	17	94	±0.6	18.5	25.5	5	16	13	G ¹ / ₂	120	±1	147	5	12	10	22	6	30	6	26	+2		
40	38	51	M6	M12X1.25	19	105		20.5	29	5	16	14.5	G ¹ / ₄	135		166	5	16	13	24	6.5	35	6.5	30	±1.3	0	
50	46.5	64	M8	M16X1.5	24	106	±0.7	28	29	6	16	15	G ¹ / ₄	143		181	±1.5	7.5	20	16	32	8	40	6.5	37		
63	56.5	74	M8	M16X1.5	24	121		27.5	35	6	16	17	G ³ / ₈	158		196		10	20	16	32	8	45	6.5	37		
80	72	94	M10	M20X1.5	30	128	±0.8	34	35	6	16	18	G ³ / ₈	174	±1.1	221		14	25	21	40	10	45	6.5	46	±1.5	+2.5
100	89	111	M10	M20X1.5	30	138		35	38.5	6	16	18	G ¹ / ₂	189		241		10	25	21	40	10	55	6.5	51	0	
125	110	136	M12	M27X2	41	160	±1	48.5	44	6	20	20	G ¹ / ₂	225	±1.2	292	±2	12	32	32	54	13	60	10	66	±2.2	+4

Output Force

(Force in N : 1N = 0.1 kgf)

Cylinder bore Ø (mm)	Rod Ø (mm)	Working pressure in bar									
		2	3	4	5	6	7	8	9	10	
32	12	124	187	249	311	373	435	498	559	621	
40	16	190	285	380	475	570	665	760	855	950	
50	20	297	445	594	742	891	1039	1187	1336	1484	
63	20	505	757	1009	1261	1514	1766	2018	2270	2523	
80	25	816	1225	1633	2041	2449	2857	3266	3674	4082	
100	25	1325	1988	2650	3313	3976	4640	5300	5965	6625	
125	32	2064	3096	4128	5160	6192	7224	8256	9288	10320	

PNEUMATIC CYLINDER IDENTIFICATION CHART (As Per ISO 15552 / VDMA 24562 Standards)

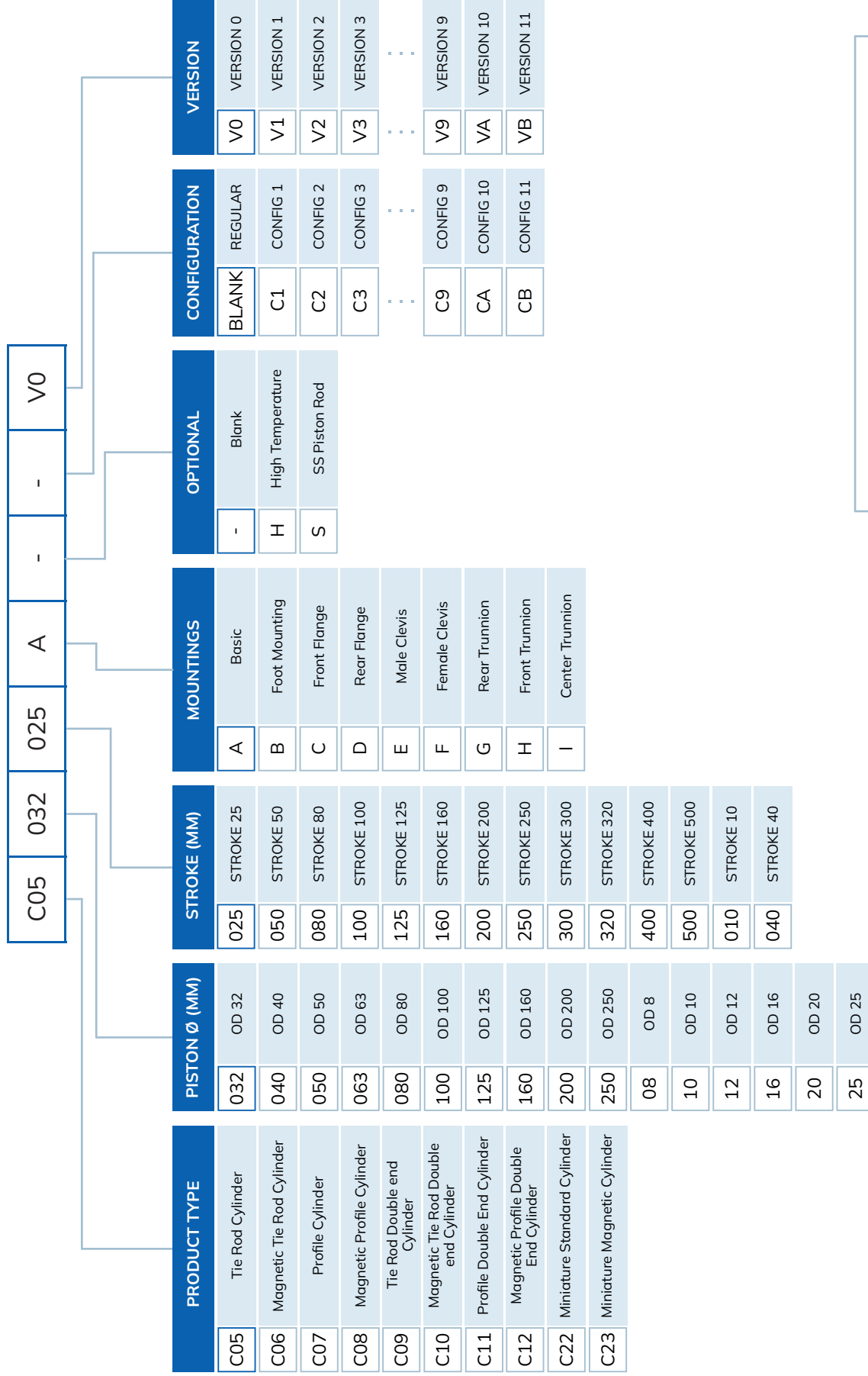

C05032025AV0
STANDARD CYLINDER OD 32-STROKE 25-BASIC

Note: The above chart is for identification purposes only, and it may not be possible to make all combinations for the above chart.

PNEUMATIC CYLINDER IDENTIFICATION CHART (As per ISO 6431 / CETOP RP43P, RP53P Standards)



C31032025AV0
STANDARD CYLINDER OD 32-STROKE 25-BASIC

Note: The above chart is for identification purposes only, and it may not be possible to make all combinations for the above chart.



AIR PREPARATION UNIT SERIES

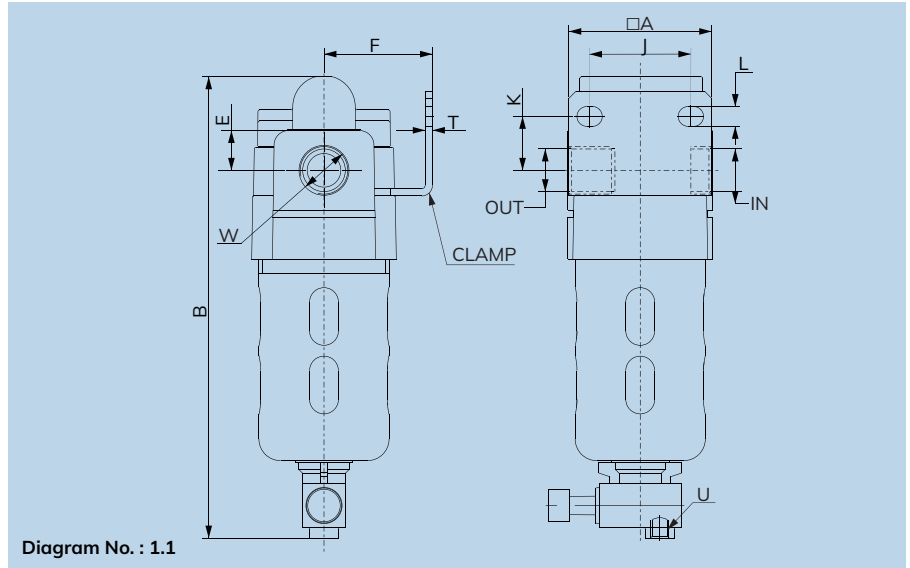

Diagram No. : 1.1

Specifications

Model No.:	F1A106BV0	F1A706BV0	F1A206BV0	F1A306BV0	F1A406BV0
Media :	Compressed air				
Port Size:	G¼	G¾	G½	G¾	G1
Flow Rate LPM *:	800	2250	3500	5000	6500
Maximum Supply Pressure:	10 Bar				
Ambient Temperature:	Manual Drain: -10°C to +50°C, Semi Auto Drain: +5°C to +50°C				
Media Temperature:	+5°C to +50°C				
Filtration (µm)	1, 5, 25, 40 (Standard), 50, 100				
Bowl Capacity (ml): (at maximum oil level)	9	32	44	165	165
Bowl Material:	Polycarbonate				
Installation:	Vertical (as in the picture)				
Materials of construction:	Aluminium, Bronze, Steel, Acetal, Polycarbonate, SS, Nitrile				
Optional accessories:	Clamp, Modular mounting kit				

*Supply Pressure 6 bar, pressure drop Δp = 0.5bar (For Standard Models)

Features

- Conforms to ISO 5782 -1
- Suitable for modular mounting
- Press type Manual drain for easy operation
- Bronze filtering element
- Separator and shield for efficient moisture separation

Precautions

- Note the direction of flow before installation and connect piping accordingly.
- Flush pipings for dirt, dust, rust and other foreign particles.
- Install in clean atmosphere.
- Nipples of taper threads to be used with teflon tape. Ensure teflon tape does not enter the unit during tightening.
- Nipples of straight threads to be used with sealing washer.
- Polycarbonate bowls may get damaged and possibly fail if exposed to synthetic oils, thinner, solvents, trichloroethylene, kerosene or other aromatic hydrocarbons.

Symbol

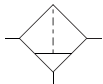

Technical Data

Model No.	Diagram No.	W	A	B	E	F	J	K	L	T	U
F1A106BV0	1.1	¼"	40	128	11	30	28	15	5.5	2	M5
F1A706BV0	1.1	¾"	55	140	14	40	40	25	6.5	2	M5
F1A206BV0	1.1	½"	70	170	18	50	55	25	8.5	2	M5
F1A306BV0	1.1	¾"	90	260	24	70	66	35	11	5	M5
F1A406BV0	1.1	1"	90	260	24	70	66	35	11	5	M5

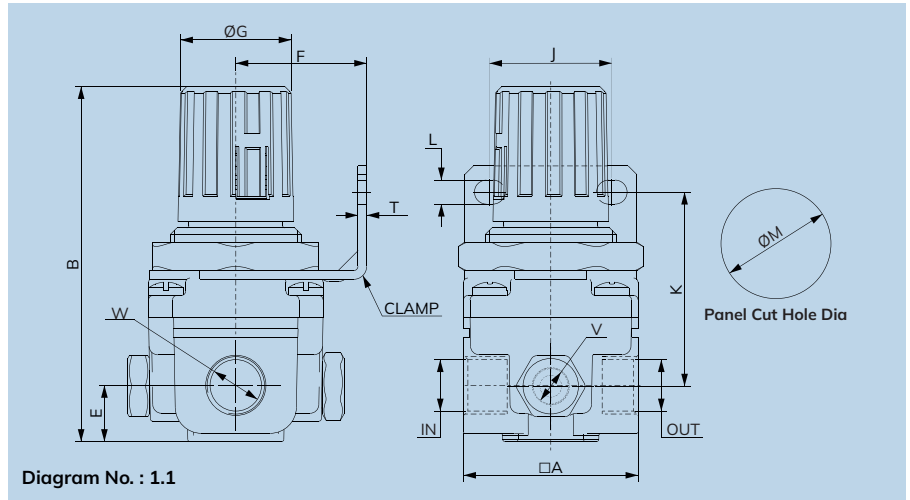

Specifications

Model No.:	R1A106BV0	R1A706BV0	R1A206BV0	R1A306BV0	R1A406BV0
Media :	Compressed air - Filtered				
Port Size:	G¼	G¾	G½	G¾	G1
Pressure Gauge Port Size:	G¾	G½	G¾	G¼	G¼
Flow Rate LPM*:	600	2500	4000	5000	6000
Maximum Supply Pressure:	15 Bar				
Regulating Pressure Range:	0.2- 2, 0.2 -4, 0.5-7, 0.5-10 (Standard)				
Media Temperature:	+5°C to +50°C				
Ambient Temperature:	-10°C to +60°C				
Installation:	Any Position				
Materials of construction:	Aluminium, Brass, Steel, Acetal, SS, Nitrile				
Optional accessories:	Clamp, Modular mounting kit, Pressure Gauge				

*Supply Pressure 7 bar, pressure drop Δp = 0.5bar (For Standard Models)

Features

- Conforms to ISO 6953 - 1
- Suitable for panel and modular mountings
- Nonraising 'Push To Lock' Adjusting Knob For Locking At Any Set Pressure
- Diaphragm operated, relieving type
- Pressure Compensated By Balanced Poppet
- Good Flow And Regulating Characteristics

Precautions

- Note the direction of flow before installation and connect piping accordingly.
- Flush pipings for dirt, dust, rust and other foreign particles.
- Install in clean atmosphere.
- Nipples of taper threads to be used with teflon tape. Ensure teflon tape does not enter the unit during tightening. Nipples of straight threads to be used with sealing washer.

Symbol

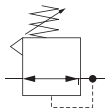

Pressure Setting

Pull the knob and adjust by turning the knob clockwise to increase the pressure. Push the knob back to its locked position. (Turning the knob counter clockwise will reduce the pressure)

Technical Data

Model No.	Diagram No.	W	V	A	B	E	F	ØG	J	K	L	T	ØM
R1A106BV0	1.1	¼"	⅝"	40	81	13	30	25	28	45	5.5	2	30.5
R1A706BV0	1.1	⅜"	⅝"	55	135	40	40	40	40	53	6.5	2	43
R1A206BV0	1.1	½"	⅝"	70	164	40	50	47	55	62	8.5	2	53
R1A306BV0	1.1	¾"	¾"	90	177	48	70	51	66	65	11	5	53
R1A406BV0	1.1	1"	¾"	90	177	48	70	51	66	65	11	5	53

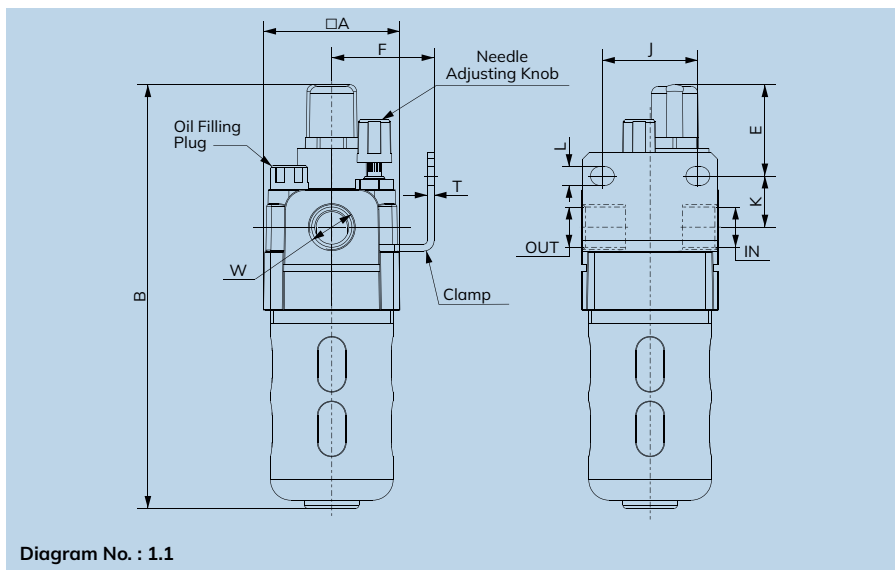

Specifications

Model No.:	L1A106BV0	L1A706BV0	L1A206BV0	L1A306BV0	L1A406BV0
Media :	Compressed air - Filtered				
Port Size:	G $\frac{1}{4}$	G $\frac{3}{8}$	G $\frac{1}{2}$	G $\frac{3}{4}$	G1
Flow Rate LPM*:	1350	3000	5650	7200	9000
Maximum Supply Pressure:	10 Bar				
Ambient Temperature:	-10°C to +50°C				
Medium Temperature:	+5°C to +50°C				
Min Operating Flow (lts/min):	12	40	45	50	50
Bowl Capacity (ml): (at maximum oil level)	20	57	152	200	200
Recommended Oil:	ISO VG 32 (Servo System 32)				
Bowl Material:	Polycarbonate				
Installation:	Vertical (as in the picture)				
Materials of construction:	Aluminium, Bronze, Steel, Acetal, Polycarbonate, SS, Nitrile				
Optional accessories:	Clamp, Modular mounting kit				

*Supply Pressure 6 bar, pressure drop $\Delta p = 0.5\text{bar}$ (For Standard Models)

Features

- Conforms to ISO 6301-1
- Suitable for modular mounting
- Fog/Mist type
- Fine adjustment of lubrication
- Lubrication proportional to flow

Symbol

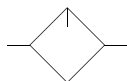

Precautions

- Note the direction of flow before installation and connect piping accordingly.
- Flush pipings for dirt, dust, rust and other foreign particles.
- Install in clean atmosphere.
- Nipples of taper threads to be used with teflon tape. Ensure teflon tape does not enter the unit during tightening. Nipples of straight threads to be used with sealing washer.
- Polycarbonate bowls may get damaged and possibly fail if exposed to synthetic oils, thinner, solvents, trichloroethylene, kerosene or other aromatic hydrocarbons.
- Oil may be filled when under pressure. However it is recommended to vent the air completely before filling the oil.

Technical Data

Model No.	Diagram No.	W	A	B	E	F	J	K	L	T
L1A106BV0	1.1	$\frac{1}{4}$ "	40	124	42	30	28	15	5.5	2
L1A706BV0	1.1	$\frac{3}{8}$ "	55	150	44	40	40	25	6.5	2
L1A206BV0	1.1	$\frac{1}{2}$ "	70	181	46	50	55	15	8.5	2
L1A306BV0	1.1	$\frac{3}{4}$ "	90	267	47	70	66	35	11	5
L1A406BV0	1.1	1"	90	267	47	70	66	35	11	5

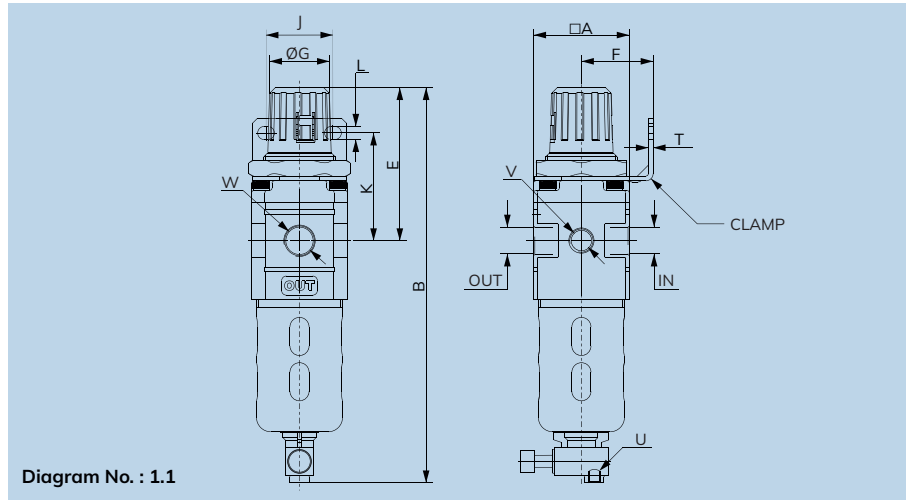

Diagram No. : 1.1

Specifications

Model No.:	FRA106BV0	FRA706BV0	FRA206BV0	FRA306BV0	FRA406BV0
Media :	Compressed Air				
Port Size:	G¼	G¾	G½	G¾	G1
Pressure Gauge Port Size:	G¾	G¾	G¾	G¼	G¼
Flow Rate LPM*:	500	1800	3000	4250	5500
Maximum Supply Pressure:	10 Bar				
Regulating Pressure Range:	0.2- 2, 0.2- 4, 0.5- 7, 0.5- 10 (Standard)				
Medium Temperature:	+5°C to +50°C				
Filteration (µm)	1, 5, 25, 40 (Standard), 50, 100				
Bowl Capacity (ml) (at maximum condensate level)	9	32	44	165	165
Bowl Material	Polycarbonate				
Installation:	Vertical				
Materials of construction:	Aluminium, Brass, Steel, Acetal, SS, Nitrile				
Optional accessories:	Clamp, Modular mounting kit, Pressure Gauge				

*Supply Pressure 7 bar, pressure drop Δp = 0.5bar (For Standard Models)

Features

- Modular type
- Suitable for panel mounting
- Filter
 - Bronze filtering element
 - Separator and shield for efficient moisture separation
- Regulator
 - Diaphragm operated, relieving type
 - Pressure compensated by balanced poppet
 - Non raising 'Press to lock' adjusting knob for locking at any set pressure
- Good flow and regulating characteristics

Precautions

- Note the direction of flow before installation and connect piping accordingly.
- Flush pipings for dirt, dust, rust and other foreign particles.
- Install in clean atmosphere.
- Nipples of taper threads to be used with teflon tape. Ensure teflon tape does not enter the unit during tightening. Nipples of straight threads to be used with sealing washer.
- Polycarbonate bowls may get damaged and possibly fail if exposed to synthetic oils, thinner, solvents, trichloroethylene kerosene or other aromatic hydrocarbons.

Pressure Setting

Pull the knob and adjust by turning the knob clockwise to increase the pressure. Push the knob back to its locked position. (Turning the knob counter clockwise will reduce the pressure)

Symbol

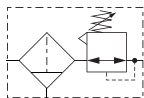

Technical Data

Model No.	Diagram No.	W	V	A	B	E	F	ØG	J	K	L	T	U
FRA106BV0	1.1	¼"	⅛"	40	165	64	30	25	28	45	5.5	2	M5
FRA706BV0	1.1	⅜"	⅛"	55	220	95	40	40	40	53	6.5	2	M5
FRA206BV0	1.1	½"	⅛"	70	287	134	50	47	55	62	8.5	2	M5
FRA306BV0	1.1	¾"	¼"	90	370	130	70	51	66	65	11	5	M5
FRA406BV0	1.1	1"	¼"	90	370	130	70	51	66	65	11	5	M5

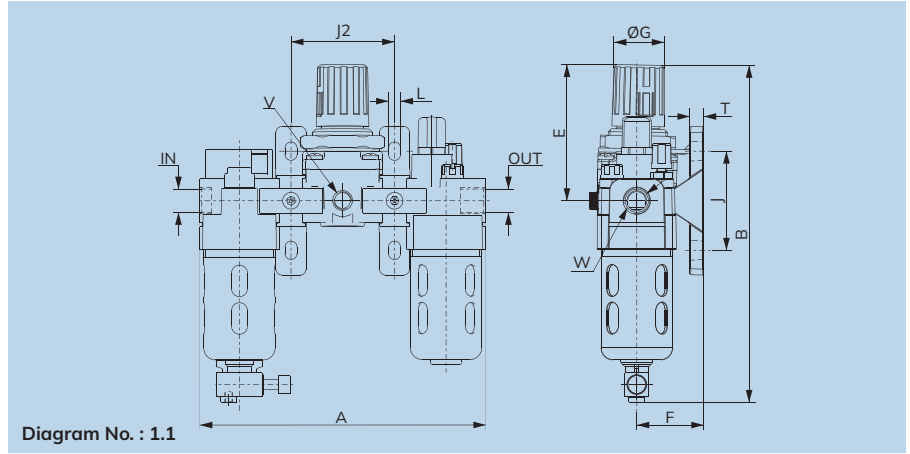
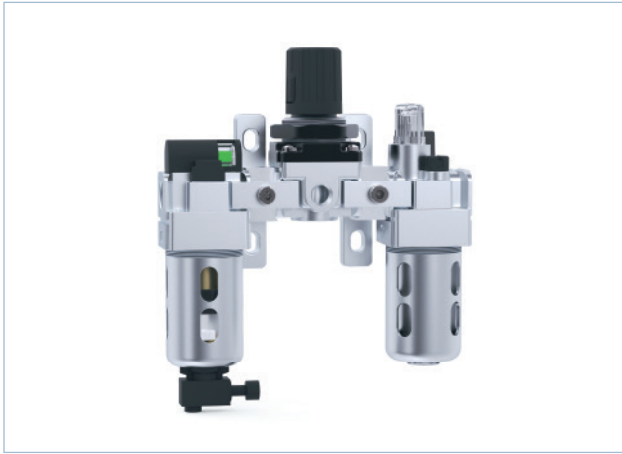

Diagram No. : 1.1

Specifications

Model No.:	F1A106BV0-R1A106BV0-L1A106BV0-MKFRL1V0	F1A706BV0-R1A706BV0-L1A706BV0-MKFRL7V0	F1A206BV0-R1A206BV0-L1A206BV0-MKFRL2V0	F1A306BV0-R1A306BV0-L1A306BV0-MKFRL3V0	F1A406BV0-R1A406BV0-L1A406BV0-MKFRL3V0
Media :	Compressed Air				
Port Size:	G $\frac{1}{4}$	G $\frac{3}{8}$	G $\frac{1}{2}$	G $\frac{3}{4}$	G1
Pressure Gauge Port Size:	G $\frac{1}{8}$	G $\frac{1}{8}$	G $\frac{1}{8}$	G $\frac{1}{4}$	G $\frac{1}{4}$
Flow Rate LPM*:	500	1250	2800	3500	4000
Maximum Supply Pressure:	10 Bar				
Regulating Pressure Range:	0.2 - 2, 0.2 - 4, 0.5 - 7, 0.5- 10 (Standard)				
Ambient Temperature:	-10°C to +50°C				
Medium Temperature:	+5°C to +50°C				
Filteration (μ m)	1, 5, 25, 40 (Standard), 50, 100				
Min Operating Flow (lts / min)	12	40	45	50	50
Bowl Capacity FRC (ml) (at maximum condensate level)	9	32	44	165	165
Bowl Capacity Lubricator (ml) (at maximum oil level)	20	57	152	200	200
Recommended Oil	ISO VG 32 (Servo System 32)				
Bowl Material	Polycarbonate				
Installation:	Vertical				
Materials of construction:	Aluminium, Brass, Steel, Acetal, SS, Nitrile				
Optional accessories:	Clamp, Modular mounting kit, Pressure Gauge				

*Supply Pressure 7 bar, pressure drop $\Delta p = 0.5$ bar (For Standard Models)

Features

- Modular type for easy and fast maintenance
- Suitable for wall mounting
- Filter
 - Bronze filtering element
 - Separator and shield for efficient moisture separation
 - Press type manual drain for easy operation
- Regulator
 - Diaphragm operated, relieving type
 - Pressure compensated by balanced poppet
 - Non raising 'Press to lock' adjusting knob for locking at any set pressure
- Lubricator
 - Fog / Mist type Lubricator
 - Fine adjustment of lubrication
 - Lubrication proportional to flow
- Good flow and regulating characteristics

Precautions

- Note the direction of flow before installation and connect piping accordingly.
- Flush pipings for dirt, dust, rust and other foreign particles.
- Install in clean atmosphere.
- Nipples of taper threads (R) to be used with teflon tape. Ensure teflon tape does not enter the unit during tightening. Nipples of straight threads (G) to be used with sealing washer.
- Polycarbonate bowls may get damaged and possibly fail if exposed to synthetic oils, thinner, solvents, trichloroethylene, kerosene or other aromatic hydrocarbons.

Pressure Setting

Pull the knob and adjust by turning the knob clockwise to increase the pressure. Push the knob back to its locked position. (Turning the knob counter clockwise will reduce the pressure)

Symbol

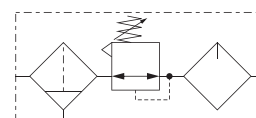

Technical Data

Model No.	Diagram No.	W	V	A	B	E	F	ØG	J	J2	L	T	U
F1A106BV0-R1A106BV0-L1A106BV0-MKFRL1V0	1.1	¼"	⅛"	145	170	68	34	25	50	52	7	7	M5
F1A706BV0-R1A706BV0-L1A706BV0-MKFRL7V0	1.1	⅜"	⅛"	192	220	95	45	40	70	69	7	7	M5
F1A206BV0-R1A206BV0-L1A206BV0-MKFRL2V0	1.1	½"	⅛"	242	275	124	53	47	90	86	9	9	M5
F1A306BV0-R1A306BV0-L1A306BV0-MKFRL3V0	1.1	¾"	¼"	300	366	130	70	51	100	105	12	10	M5
F1A406BV0-R1A406BV0-L1A406BV0-MKFRL3V0	1.1	1"	¼"	300	366	130	70	51	100	105	12	10	M5

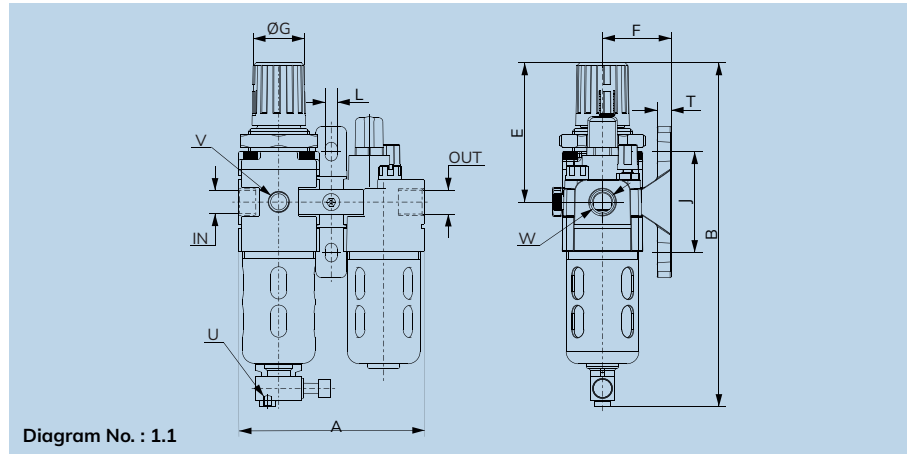
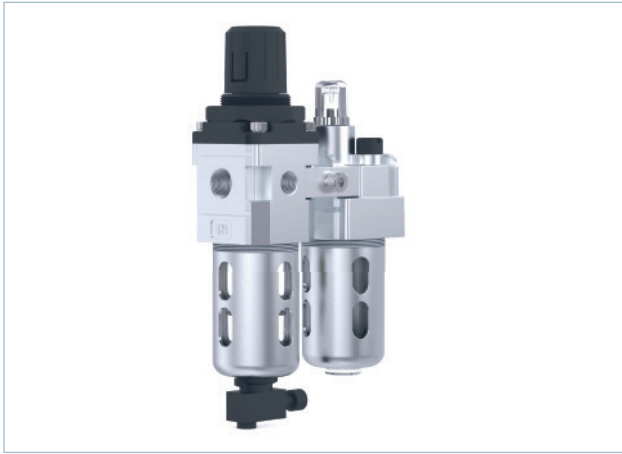

Specifications

Model No.:	FRA106BV0-L1A106BV0 -MKFRL1V0	FRA706BV0-L1A706BV0 -MKFRL7V0	FRA206BV0-L1A206BV0 -MKFRL2V0	FRA306BV0-L1A306BV0 -MKFRL3V0	FRA406BV0-L1A406BV0 -MKFRL3V0
Media :	Compressed Air				
Port Size:	G $\frac{1}{4}$	G $\frac{3}{8}$	G $\frac{1}{2}$	G $\frac{3}{4}$	G1
Pressure Gauge Port Size:	G $\frac{1}{8}$	G $\frac{1}{8}$	G $\frac{1}{8}$	G $\frac{1}{4}$	G $\frac{1}{4}$
Flow Rate LPM*:	500	1250	2800	3500	4000
Maximum Supply Pressure:	10 Bar				
Regulating Pressure Range:	0.2- 2, 0.2- 4, 0.5- 7, 0.5- 10 (Standard)				
Ambient Temperature:	-10°C to +50°C				
Medium Temperature:	+5°C to +50°C				
Filteration (μ m)	1, 5, 25, 40 (Standard), 50, 100				
Min Operating Flow (lts / min)	12	40	45	50	50
Bowl Capacity FRC (ml) (at maximum condensate level)	9	32	44	165	165
Bowl Capacity Lubricator (ml) (at maximum oil level)	20	57	152	200	200
Recommended Oil	ISO VG 32 (Servo System 32)				
Bowl Material	Polycarbonate				
Installation:	Vertical				
Materials of construction:	Aluminium, Brass, Steel, Acetal, SS, Nitrile				
Optional accessories:	Clamp, Modular mounting kit, Pressure Gauge				

*Supply Pressure 7 bar, pressure drop $\Delta p = 0.5$ bar (For Standard Models)

Features

- Modular type for easy and fast maintenance
- Suitable for wall mounting
- Filter
 - Bronze filtering element
 - Separator and shield for efficient moisture separation
 - Press type manual drain for easy operation
- Regulator
 - Diaphragm operated, relieving type
 - Pressure compensated by balanced poppet
 - Non raising 'Press to lock' adjusting knob for locking at any set pressure
- Lubricator
 - Fog / Mist type Lubricator
 - Fine adjustment of lubrication
 - Lubrication proportional to flow
- Good flow and regulating characteristics

Precautions

- Note the direction of flow before installation and connect piping accordingly.
- Flush pipings for dirt, dust, rust and other foreign particles.
- Install in clean atmosphere.
- Nipples of taper threads (R) to be used with teflon tape. Ensure teflon tape does not enter the unit during tightening. Nipples of straight threads (G) to be used with sealing washer.
- Polycarbonate bowls may get damaged and possibly fail if exposed to synthetic oils, thinner, solvents, trichloroethylene, kerosene or other aromatic hydrocarbons.

Pressure Setting

Pull the knob and adjust by turning the knob clockwise to increase the pressure. Push the knob back to its locked position. (Turning the knob counter clockwise will reduce the pressure)

Symbol

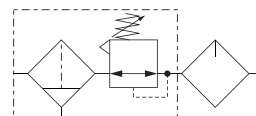

Technical Data

Model No.	Diagram No.	W	V	A	B	E	F	ØG	J	L	T	U
FRA106BV0-L1A106BV0 -MKFRL1V0	1.1	¼"	⅛"	92	170	69	34	25	50	7	7	M5
FRA706BV0-L1A706BV0 -MKFRL7V0	1.1	⅜"	⅛"	124	220	95	45	40	70	7	7	M5
FRA206BV0-L1A206BV0 -MKFRL2V0	1.1	½"	⅛"	155	276	123	53	47	90	9	9	M5
FRA306BV0-L1A306BV0 -MKFRL3V0	1.1	¾"	¼"	200	370	130	70	51	100	12	10	M5
FRA406BV0-L1A406BV0 -MKFRL3V0	1.1	1"	¼"	200	370	130	70	51	100	12	10	M5

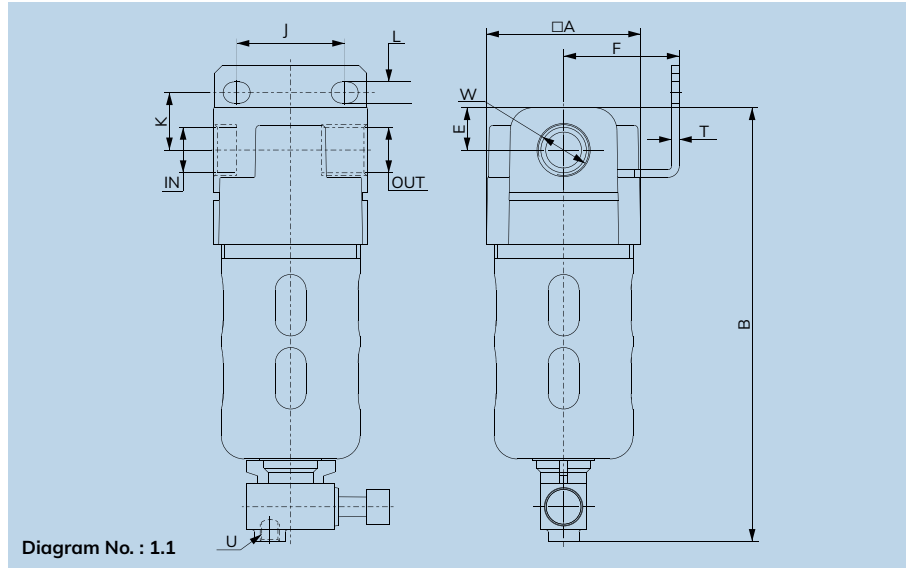

Specifications

Model No.:	FS1A106BV0		FS1A206BV0	
Medium:	Compressed air - Filtered			
Port Size:	G¼		G½	
Filteration (µm):	0.01	0.1	0.01	0.1
Flow Rate(Its/min)*:	250	275	1500	2000
Maximum Supply Pressure:	10 Bar			
Ambient Temperature:	-10°C to +50°C			
Medium Temperature:	+5°C to +50°C			
Bowl Capacity (ml): (at maximum oil level)	9		44	
Bowl Material:	Polycarbonate			
Installation:	Vertical (as in the picture)			
Application:	These type of mist separators are used in Chemical, Pharmaceutical, Food processing industry, Paintshops and for other precision pneumatic systems.			
Materials of construction:	Aluminium, Bronze, Steel, Acetal, Polycarbonate, SS, Nitrile			
Optional accessories:	Clamp, Modular mounting kit			

*Supply Pressure 6 bar, pressure drop Δp = 0.3bar (For Standard Models)

Features

- Borosilicate filtering element
- 99.99% compressed filtered air upto 0.01micron to 0.1 micron
- Suitable for Modular mounting
- Press type Manual drain for easy operation
- Separator for efficient moisture separation

Precautions

- Mount the mist separator in line, next to a standard air filter series F1with 5 micron filter element.
- Note the direction of flow before installation and connect piping accordingly.
- Flush pipings for dirt, dust,rust and other foreign particles.
- Install in clean atmosphere.
- Nipples of taper threads (R) to be usedwith teflon tape. Ensure Teflon tape does not enter the unit during tightening. Nipples of straight threads (G) to be used with sealing washer.
- Polycarbonate bowls may get damaged and possibly fail if exposed to synthetic oils, thinner, solvents, trichloroethylene kerosene or other aromatic hydrocarbons.

Function

- Removes submicronic oil, water droplets and solid contaminants from compressed air.
- Used for high efficient filtration of compressed air, removing fine oil particles and droplets of sizes upto 0.01 microns

Technical Data

Model No.	Diagram No.	W	A	B	E	F	J	K	L	T	U
FS1A106BV0	1.1	¼"	40	113	11	30	28	15	5.5	2	M5
FS1A206BV0	1.1	½"	70	172	18	50	55	25	8.5	2	M5

AIR PREPARATION UNITS VALVE MODEL IDENTIFICATION CHART

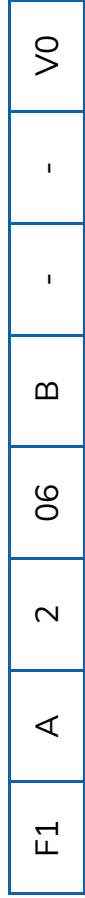

PRODUCT TYPE	BODY MATERIAL	PORT SIZE	PRESSURE RANGE	Port Connection	FEATURES	CONFIGURATION	VERSION
F1	A	1	06	B	REGULAR	-	V0
FR		7		N	Regulator With NRV	C1	V1
L1		2			Internal Autodrain	C2	V2
R1		3			With Metal bowl	C3	V3
S1		4			With Modular	⋮	⋮
					Without Piping Adaptor	C9	V9
					With Pressure Gauge	CA	VA
					With Service Indicator	CB	VB

F1A206BV0
1/2" FILTER ALUMINIUM-0.5 TO 10 Bar-BSP

Note: The above chart is for identification purposes only, and it may not be possible to make all combinations for the above chart.



Valve Specifications

Type :	Piston Type, Self Relieving
Body :	WCB, Aluminium
Port Size :	½" BSP Female
Orifice :	12mm
Seals :	Nitrile (NBR)
Media :	Compressed Air (Filtered & Lubricated)
Temperature :	+5°C to +50°C
Pressure Range :	Inlet - 3 to 42 bar, Regulated 0 to 42 bar
Flow (NLPM) at 5 Bar :	2500 Normal litres per min.

Dimension Drawing (All dimensions in mm)

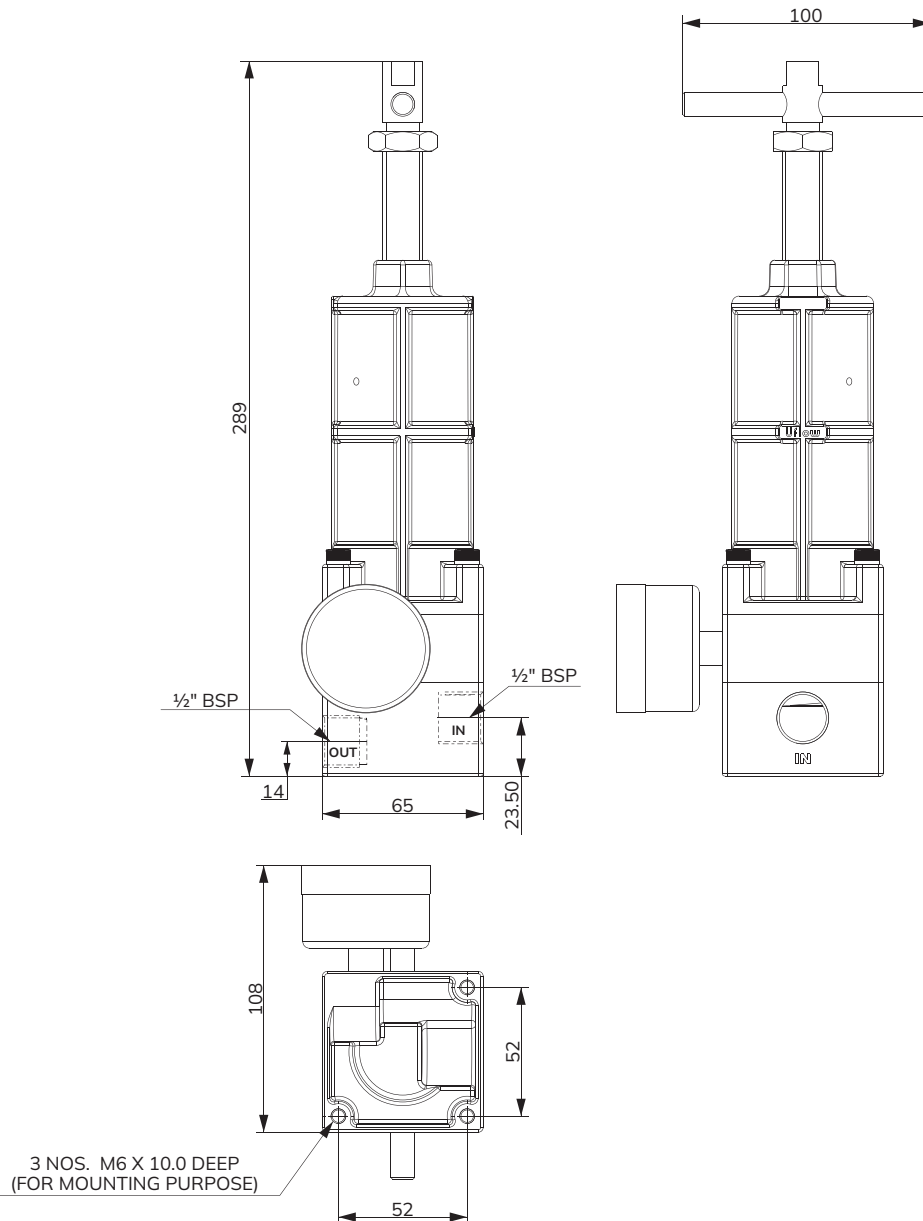

HIGH PRESSURE REGULATOR MODEL IDENTIFICATION CHART

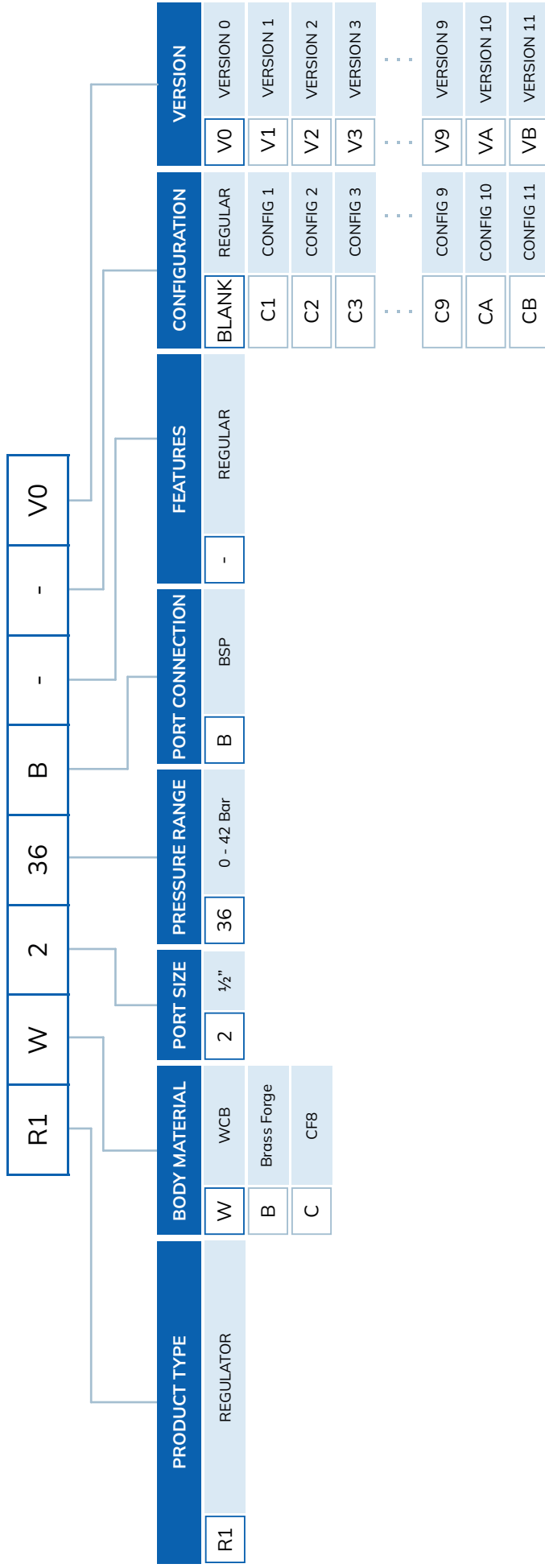

R1W236BV0
1/2" REGULATOR WCB-0 TO 42 BAR-BSP

Note: The above chart is for identification purposes only, and it may not be possible to make all combinations for the above chart.



**ONE TOUCH FITTINGS
SERIES**

Specifications

Media :	Air
Max. operating pressure :	10 Bar
Ambient temperature :	-10°C to +60°C
Threaded connection :	Male : R - Taper thread, Female : G - Parallel thread
Media temperature :	+5°C to +50°C
Applicable tube material :	Nylon, Polyurethane
Applicable tube size (OD) :	Ø4, Ø6, Ø8, Ø10, Ø12, Ø14, Ø16
Recommended tolerance for tube OD :	±0.1 mm
Recommended minimum wall thickness of tubes :	

Nylon		PU	
Tube OD (mm)	Thickness (mm)	Tube OD (mm)	Thickness (mm)
Ø4	1	Ø4	1
Ø6		Ø6	1
Ø8		Ø8	1.5
Ø10		Ø10	1.5
Ø12		Ø12	2
Ø14		Ø14	2
Ø16		Ø16	2.5

Features

- ☑ Compact & Captivating Design
- ☑ All Threaded nipples has plastic portion that is capable of rotating 360°
- ☑ Full bore piping enables smooth flow of fluids.
- ☑ New Design SS collet
- ☑ Air tight sealing of tubes
- ☑ Compatible with both Nylon & PU pipes
- ☑ Male Taper threads with PTFE coating
- ☑ Durable & Maintenance free
- ☑ Robust collet design lets the fitment & function remains unaffected even due to vibration.
- ☑ Simple & fast connection of tube just by plugging-in manually and similarly smooth way of pulling-out just by the press of plastic collet cap.

Application

One-touch fitting can be effectively used in all compressed air applications Some of the pneumatic application include

- ☑ Pneumatic cylinders (all types)
- ☑ All compressed air lines, machinery of all kinds wherever pneumatic systems are used
- ☑ Directional control valves(DCV), solenoid valves(SOV) and other valves
- ☑ Pneumatic control & circuit panels
- ☑ Air preparation units like filter, regulator and lubricators(FRL)

Straight Union

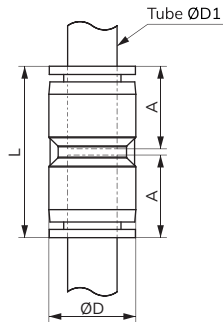

Model No.	Tube OD - ØD1	ØD	L	A
VO210404V0	4	11	31	12
VO210606V0	6	13	33	15
VO210808V0	8	15	35	16
VO211010V0	10	19	39	18
VO211212V0	12	21	42	20
VO211414V0	14	23	42	20
VO211616V0	16	26	46	22

Different Dia. Straight Union

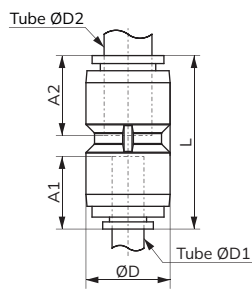

Model No.	Tube OD		ØD	L	A1	A2
	ØD1	ØD2				
VO220406V1	4	6	13	35	16	15
VO220608V1	6	8	15	37	16	16
VO220610V0	6	10	19	41	17	18
VO220810V1	8	10	19	41	18	18
VO220812V0	8	12	21	44	18	20
VO221012V1	10	12	31	44	20	20
VO221216V0	12	16	26	48	22	22

Union Elbow Reducer

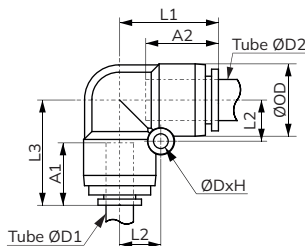

Model No.	Tube OD		ØD	L1	L2	L3	A1	A2	ØDxH
	ØD1	ØD2							
VO240812V0	8	12	21	31	12	29	18	21	Ø4.3X21.5

Union Elbow

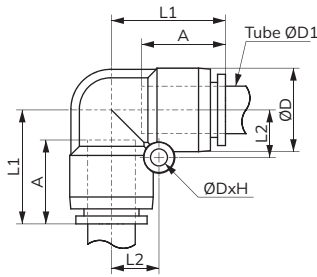

Model No.	Tube OD ØD1	ØD	L1	L2	A	ØDxH
VO230404V0	4	11	18	7	15	Ø3.3X11
VO230606V0	6	13	20	8	15	Ø3.3X13
VO230808V0	8	15	25	9	17	Ø3.3X15.5
VO231010V0	10	19	26	11	19	Ø4.3X19
VO231212V0	12	21	29	12	21	Ø4.3X21.5
VO231414V0	14	23	30	13	21	Ø4.3X23.5
VO231616V0	16	26	31	15	22	Ø4.3X26

Union Tee

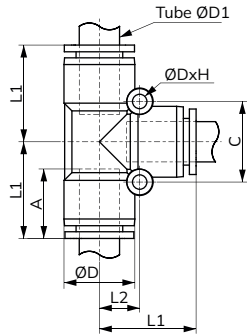

Model No.	Tube OD ØD1	ØD	L1	L2	C	A	ØDxH
VO250404V0	4	10.6	17.7	6.5	13	14.9	Ø3.3X11
VO250606V0	6	12.8	20	7.5	15	16	Ø3.3X13
VO250808V0	8	15	24	9	18	17.2	Ø3.3X15.5
VO251010V0	10	18.5	26.4	11	22	19.2	Ø4.3X19
VO251212V0	12	21.1	28.8	12	24	20.7	Ø4.3X20.5
VO251414V0	14	23.1	29.8	13	26	20.7	Ø4.3X23.5
VO251616V0	16	25.6	31.3	14.5	29	22.2	Ø4.3X26

Union Tee Reducer

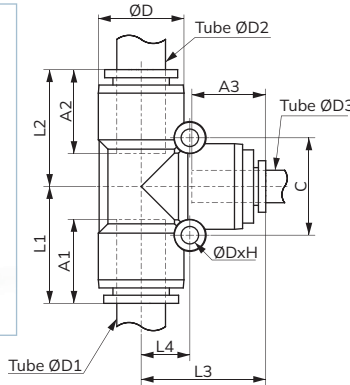

Model No.	Tube OD			ØD	L1	L2	L3	L4	C	A1	A2	A3	ØDxH
	ØD1	ØD2	ØD3										
VO26040406V0	4	4	6	12.6	22.8	22.8	20	7.5	15	12.4	12.4	16	Ø3.3X13
VO26060604V0	6	6	4	12.6	20	20	22.8	7.5	15	16	16	12.4	Ø3.3X13
VO26060608V0	6	6	8	15	26	26	24	9	18	16.3	16.3	17.2	Ø3.3X15.5
VO26061212V0	6	12	12	21.1	30.2	28.8	28.8	12	24	17.3	20.7	20.7	Ø4.3X20.5
VO26080806V0	8	8	6	15	24	24	26	9	18	17.2	17.2	16.3	Ø3.3X15.5
VO26080810V0	8	8	10	18.5	28.7	28.7	26.4	11	22	17.7	17.7	19.2	Ø4.3X19
VO26081212V0	8	12	12	21.1	30.7	28.8	28.8	12	24	18.2	20.7	20.7	Ø4.3X24
VO26101006V0	10	10	6	18.5	26.4	26.4	28.2	11	22	19.2	19.2	17.2	Ø4.3X19
VO26101008V0	10	10	8	18.5	26.4	26.4	28.7	11	22	19.2	19.2	17.7	Ø4.3X19
VO26101012V0	10	10	12	21.1	31.2	31.2	28.8	12	24	20.2	20.2	20.7	Ø4.3X20.5
VO26121206V0	12	12	6	21.1	28.8	28.8	30.2	12	24	20.7	20.7	17.3	Ø4.3X20.5
VO26121208V0	12	12	8	21.1	28.8	28.8	30.7	12	24	20.7	20.7	18.2	Ø4.3X20.5
VO26121210V0	12	12	10	21.1	28.8	28.8	30.2	12	24	20.7	20.7	20.2	Ø4.3X20.5

Union 'Y'

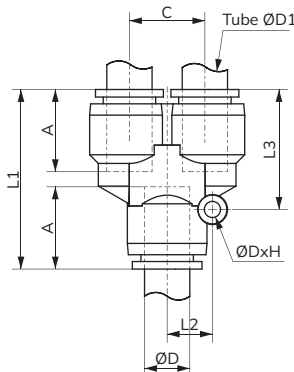

Model No.	Tube OD ØD1	ØD	L1	L2	L3	C	A	ØDxH
VO270404V0	4	10.6	31.4	6.5	21.3	10	14.9	Ø3.3X11
VO270606V0	6	12.8	34	7.5	22.5	12	16	Ø3.3X13
VO270808V0	8	15	39	9	26.5	14.5	17.2	Ø3.3X15.5
VO271010V0	10	18.5	45.3	11	29.9	18	19.2	Ø4.3X19
VO271212V0	12	21.1	47.6	12	31.8	20	21.8	Ø4.3X21.5

Union 'Y' Reducer

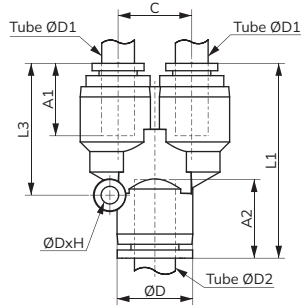

Model No.	Tube OD		ØD	L1	L2	L3	C	A1	A2	ØDxH
	ØD1	ØD2								
VO28040406V0	4	6	12.6	36.8	7.5	25.3	12	15.9	16	Ø3.3X13
VO28060608V0	6	8	15	41.1	9	28.6	14.5	16.3	17.2	Ø3.3X15.5
VO28080810V0	8	10	18.5	47.6	11	32.2	18	19.2	17.7	Ø4.3X19

Bulk Head Union

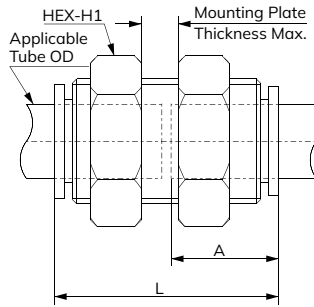

Model No.	Tube OD	HEX	L	A	Mounting Plate Thickness Max.	Mounting Hole Dia.
VO2904V0	4	14	32	15	16	13
VO2906V0	6	17	33	16	14	15
VO2908V0	8	19	34	16	12	17
VO2910V0	10	24	38	18	12	21
VO2912V0	12	27	39	19	12	23
VO2914V0	14	30	40	19	10	25
VO2916V0	16	32	49	24	12	28

Male Connector

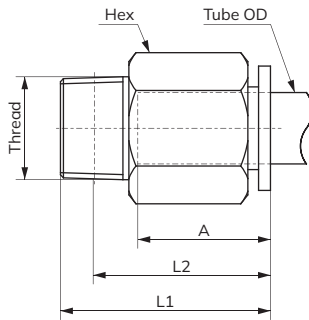

Model No.	Tube OD	Thread	Hex	L1	L2	A
VO3004AV0	4	M5 x 0.8	10	21.2	17.2	14.4
VO3004CV0		R1/4	14	18.2	12.7	14.4
VO3004BV0		R1/8	10	21.7	18	14.4
VO3006AV0	6	M5 x 0.8	12	21.5	17.5	15.3
VO3006BV0		R1/8	12	22.5	19	16.3
VO3006CV0		R1/4	14	25	19.75	16.3
VO3006DV0		R3/8	17	20	14.74	16.3
VO3008BV0	8	R1/8	14	25	21	16.7
VO3008CV0		R1/4	14	27	21.75	17
VO3008DV0		R3/8	17	23	16.5	16.7
VO3008EV0		R1/2	22	25	18	17
VO3010CV0	10	R1/4	17	29.9	23.9	19.7
VO3010DV0		R3/8	17	29.9	23.9	19.7
VO3010EV0		R1/2	22	25.4	17.9	18.7
VO3012CV0	12	R1/4	22	36.8	30.8	22.3
VO3012DV0		R3/8	22	35.3	29.55	22.3
VO3012EV0		R1/2	22	32.8	25.3	22.3
VO3012GV0		G1/4	22	36.8	30.8	22.3
VO3012IV0		G3/8	22	35.3	29.46	22.3
VO3012JV0		G1/2	22	32.8	25.3	22.3
VO3014JV0	14	G1/2	24	33.8	26.3	22.2
VO3014HV0		G3/4	27	33.8	26.3	22.2
VO3016JV0	16	G1/2	24	38.3	30.3	23.7
VO3016HV0		G3/4	27	32.3	23.8	21.7
VO3016KV0		G1	36	38.3	28.8	23.7

Bulk Head Female Connector

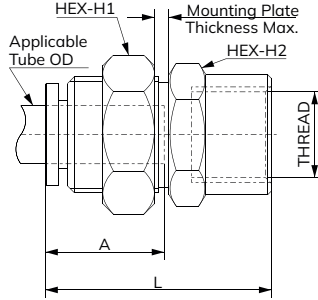

Model No.	Tube OD	Thread	HEX H1	HEX H2	L	A	Mounting Plate Thickness Max.	Mounting Hole Dia.
VO3106GV0	6	G1/4	17	17	32	16	8	15
VO3108GV0	8	G1/4	19	17	32	16	7	17

Female Connector

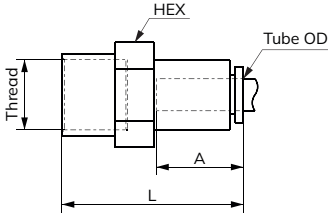

Model No.	Tube OD	Thread	Hex	L	A
VO3204FV0	4	G1/8	14	27	14.5
VO3204GV0		G1/4	17	31	14.5
VO3206FV0	6	G1/8	14	27	15.5
VO3206GV0		G1/4	17	31.5	15.5
VO3208FV0	8	G1/8	14	27	16
VO3208GV0		G1/4	17	31.5	16
VO3208IV0	10	G3/8	22	33.5	16
VO3210GV0		G1/4	17	33	18
VO3210IV0	12	G3/8	22	35	18
VO3212IV0		G3/8	22	35	18.5
VO3212JV0	14	G1/2	27	39.5	18.5
VO3214JV0		G1/2	27	39	19

Male Elbow

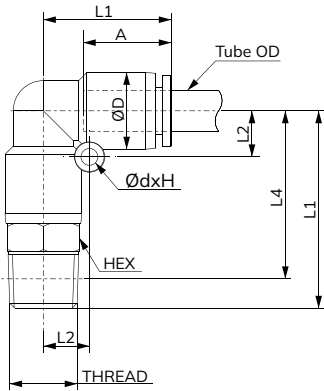

Model No.	Tube OD	Thread	HEX	ØD	L1	L2	L3	L4	A	ØdxH
VO3304AV0	4	M5X0.8	9	11	18	7	25	20	15	3.3x11
VO3304BV0		R1/8	10	11	18	7	30	27	15	3.3x11
VO3304CV0		R1/4	14	11	18	7	32	27	15	3.3x11
VO3306AV0	6	M5X0.8	11	13	20	8	28	25	15	3.3x13
VO3306BV0		R1/8	12	13	20	8	32	28	15	3.3x13
VO3306CV0		R1/4	14	13	20	8	34	28	15	3.3x13
VO3306DV0	8	R3/8	17	13	20	8	35	29	15	3.3x13
VO3308BV0		R1/8	14	15	25	9	35	31	17	3.3x15.5
VO3308CV0		R1/4	14	15	25	9	39	33	17	3.3x15.5
VO3308DV0	10	R3/8	17	15	25	9	37	31	17	3.3x15.5
VO3308EV0		R1/2	22	15	25	9	42	35	17	3.3x15.5
VO3310CV0		R1/4	17	19	26	11	42	37	19	4.3x19
VO3310DV0	12	R3/8	17	19	26	11	42	36	19	4.3x19
VO3310EV0		R1/2	22	19	26	11	46	38	19	4.3x19
VO3312CV0		R1/4	19	21	29	12	45	39	21	4.3x21.5
VO3312DV0	14	R3/8	19	21	29	12	45	39	21	4.3x21.5
VO3312EV0		R1/2	22	21	29	12	47	40	21	4.3x21.5
VO3314JV0		G1/2	22	23	30	13	51	43	21	4.3x26
VO3314HV0	16	G3/4	27	23	30	13	52	43	21	4.3x26
VO3316JV0		G1/2	24	26	31	15	54	47	22	4.3x26
VO3316HV0		G3/4	27	26	31	15	54	45	22	4.3x26
VO3316KV0	16	G1	36	26	31	15	61	51	22	4.3x26
VO3316KV0		G1	36	26	31	15	61	51	22	4.3x26

Female Elbow

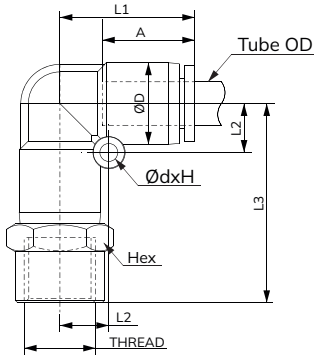

Model No.	Tube OD	Thread	HEX	ØD	L1	L2	L3	A	ØdXH
VO3506FV0	6	G1/8	14	13	20	8	28	15	3.3x11
VO3506GV0		G1/4	17	13	20	8	33	15	3.3x11
VO3508GV0	8	G1/4	17	15	25	9	37	17	3.3x15.5
VO3514JV0	14	G1/2	27	23	29	13	46	21	4.3x23.5

Male Branch Tee

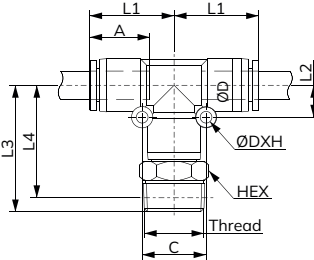

Model No.	Tube OD	Thread	HEX	ØD	L1	L2	L3	L4	C	ØdXH
VO3604BV0	4	R1/8	10	10.5	18.5	6.5	30	27	13	3.3 x11
VO3604CV0		R1/4	14	10.5	18.5	6.5	32	27	13	3.3 x11
VO3606BV0	6	R1/8	12	12.5	20	7.5	31.5	28	15	3.3 x13
VO3606CV0		R1/4	14	12.5	20	7.5	33.5	28	15	3.3 x13
VO3608BV0	8	R1/8	14	15	22	9	33.5	30	18	3.3 x15.5
VO3608CV0		R1/4	14	15	22	9	37	32	18	3.3 x15.5
VO3608DV0	10	R3/8	17	15	22	9	36.5	31	18	3.3 x15.5
VO3610CV0		R1/4	17	18.5	26	11	41.5	36	22	4.3 x19
VO3610DV0	12	R3/8	17	18.5	26	11	42	36	22	4.3 x19
VO3612DV0		R3/8	19	21	27.5	12	44.5	39	24	4.3 x20.5
VO3612EV0	14	R1/2	22	21	27.5	12	47	40	24	4.3 x20.5
VO3614EV0		R1/2	22	23	29	13	50.5	43	26	4.3 x26

Female Branch Tee

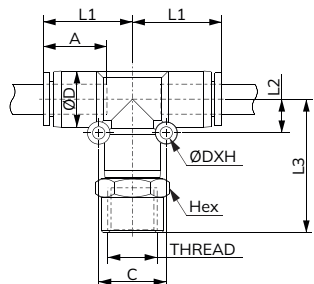

Model No.	Tube OD	Thread	HEX	ØD	L1	L2	L3	C	A	ØdXH
VO3706FV0	6	G1/8	14	13	20	8	28	15	16	3.3 x13
VO3706GV0		G1/4	17	13	20	8	33	15	16	3.3 x13
VO3708GV0	8	G1/4	17	15	22	9	34	18	16	3.3 x15.5

Female Run Tee

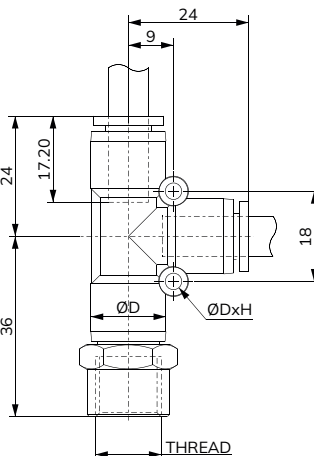

Model No.	Tube OD	Thread	HEX	ØD	L1	L2	L3	C	A	ØdXH
VO3906FV0	6	G1/8	14	13	20	8	28	15	16	3.3 x13
VO3906GV0		G1/4	17	13	20	8	33	15	16	3.3 x13
VO3908GV0	8	G1/4	17	15	22	9	34	18	16	3.3 x15.5

Male Run Tee

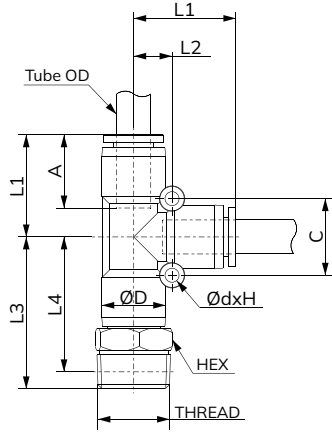

Model No.	Tube OD	Thread	HEX	ØD	L1	L2	L3	L4	C	ØdxH
VO3804BV0	4	R1/8	10	10.5	18.5	6.5	30	26.5	13	3.3 x11
VO3804CV0		R1/4	14	10.5	18.5	6.5	32	26.5	13	3.3 x11
VO3806BV0	6	R1/8	12	12.5	20	7.5	31.5	28	15	3.3 x13
VO3806CV0		R1/4	14	12.5	20	7.5	33.5	28	15	3.3 x13
VO3808BV0	8	R1/8	14	15	22	9	33.5	30	18	3.3 x15.5
VO3808CV0		R1/4	14	15	22	9	37	31.5	18	3.3 x15.5
VO3808DV0	10	R3/8	17	15	22	9	36.5	30.5	18	3.3 x15.5
VO3810CV0		R1/4	17	18.5	26	11	41.5	36	22	4.3 x19
VO3810DV0	12	R3/8	17	18.5	26	11	42	36	22	4.3 x19
VO3812DV0		R3/8	19	21	27.5	12	44.5	38.5	24	4.3 x20.5
VO3812EV0		R1/2	22	21	27.5	12	47	39.5	24	4.3 x20.5

Male Branch Y

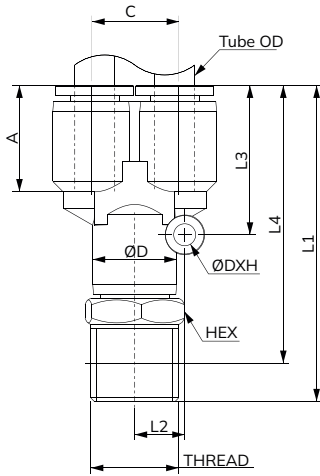

Model No.	Tube OD	Thread	HEX	ØD	L1	L2	L3	L4	C	A	ØDXH
VO4004BV0	4	R1/8	10	11	43	7	19	39	10	15	3.3 X 11
VO4004CV0		R1/4	14	11	45	7	19	39	10	15	3.3 X11
VO4006BV0	6	R1/8	12	13	46	8	22	43	12	16	3.3 X13
VO4006CV0		R1/4	14	13	48	8	22	43	12	16	3.3 X13
VO4008BV0	8	R1/8	14	15	50	9	25	46	15	16	3.3 X15.5
VO4008CV0		R1/4	14	15	53	9	25	48	15	16	3.3 X15.5
VO4008DV0		R3/8	17	15	53	9	25	47	15	16	3.3 X15.5
VO4010CV0	10	R1/4	17	19	60	11	30	54	18	18	4.3 X19
VO4010DV0		R3/8	17	19	60	11	30	54	18	18	4.3 X19
VO4012DV0	12	R3/8	19	21	64	12	32	58	20	19	4.3 X21.5
VO4012EV0		R1/2	22	21	67	12	32	59	20	19	4.3 X21.5

Cross Union

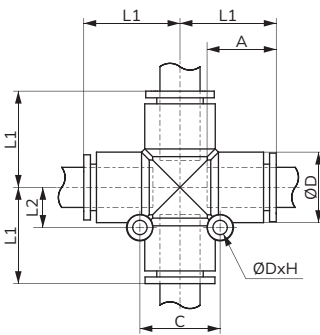

Model No.	Tube OD	ØD	L1	L2	C	A	ØDXH
VO490404V0	4	10.6	17.7	6.5	13	14.9	Ø3.3X11
VO490606V0	6	12.6	20	7.5	15	16	Ø3.3X13
VO490808V0	8	15	25	9	18	17.2	Ø3.3X15.5
VO491010V0	10	18.5	26.4	11	22	19.2	Ø4.3X19
VO491212V0	12	21.1	28.8	12	24	20.7	Ø4.3X21.5

Plug

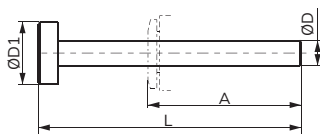

Model No.	Applicable Fitting size ØD	ØD1	L	A
VO5004V0	4	10	42	15
VO5006V0	6	12	44	16
VO5008V0	8	14	46	17
VO5010V0	10	16	48	20
VO5012V0	12	18	52	21
VO5014V0	14	20	45	22
VO5016V0	16	18	47	23

Specifications

Type	Supply control	Exhaust control
Model	VF52	VF55
Free flow	2 → 1	1 → 2
Controlled flow	1 → 2	2 → 1
Media	Compressed air - Dry / Lubricated	
Operating pressure range	1 - 10 bar	
Ambient Temperature	+5° to +60° C	
Materials of construction	Brass, Acetal, Nitrile	
Applicable tubes	Nylon, Polyurethane	

Features

- ☑ Directly mountable on cylinder / valve ports
- ☑ Can be rotated by 360°
- ☑ Fine regulation of air flow
- ☑ Nickel plated body
- ☑ Male threads(R) teflon coated
- ☑ Elegant design and finish

Application

- ☑ These valves are used to control the speed of piston in a pneumatic cylinder.

Function

- ☑ These valves allow controlled flow of air in one direction and free flow in the other direction.
- ☑ These are available in two versions - a) Supply control version, and b) Exhaust control version.

Symbol

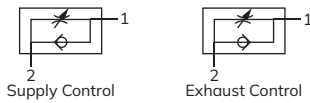

Flow Control - R Series

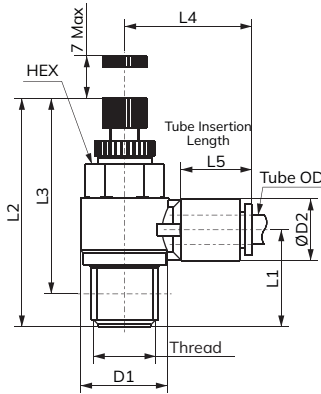

Model No.	Thread	Tube OD	Hex	L1	L2	L3	L4	L5	ØD1	ØD2	Free Flow Min. Lts/min	Free Flow Min. Lts/min
VF5204BV0	R1/8	4		15.5	39	35.5	22	14.5	13.5	10.5	100	100
VF5504BV0		6	12	16	39	35.5	23	15.5	13.5	12.5	200	140
VF5206BV0		8		18	39	35.5	27	17	13.5	15	200	140
VF5506BV0												
VF5206CV0	R1/4	6		20.5	47	41.5	25	15.5	18	12.5	400	350
VF5506CV0		8	14	21	47	41.5	27.5	17	18	15	550	420
VF5208CV0		10		23	47	41.5	32.5	20	18	18.5	650	450
VF5508CV0												
VF5210CV0	R3/8	8		25	53	47	29.5	17	22	15	1100	930
VF5508DV0		10	19	26	53	47	34.5	20	22	18.5	1300	1000
VF5210DV0		12		27	53	47	36	20.5	22	21	1400	1050
VF5510DV0												
VF5208EV0	R1/2	8		27.5	57	49.5	32.5	17	28	15	1400	1250
VF5508EV0		10	24	28.5	57	49.5	36.5	20	28	18.5	1750	1500
VF5210EV0		12		29.5	57	49.5	37.5	20.5	28	21	1900	1600
VF5510EV0												
VF5212EV0												
VF5512EV0												

Flow Control - M Series

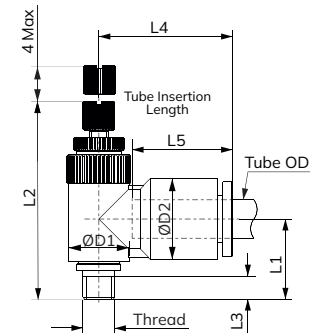

Model No.	Thread	Tube OD	L1	L2	L3	L4	L5	ØD1	ØD2	Free Flow Min. Lts/min	Free Flow Min. Lts/min
VF5204AV0	M5	4	12.5	31	3.5	20	14.5	9.5	10.5	60	45
VF5504AV0		6	12.5	31	3.5	21	15.5	9.5	12.5	100	50
VF5206AV0											
VF5506AV0											

ONE TOUCH FITTINGS IDENTIFICATION CHART

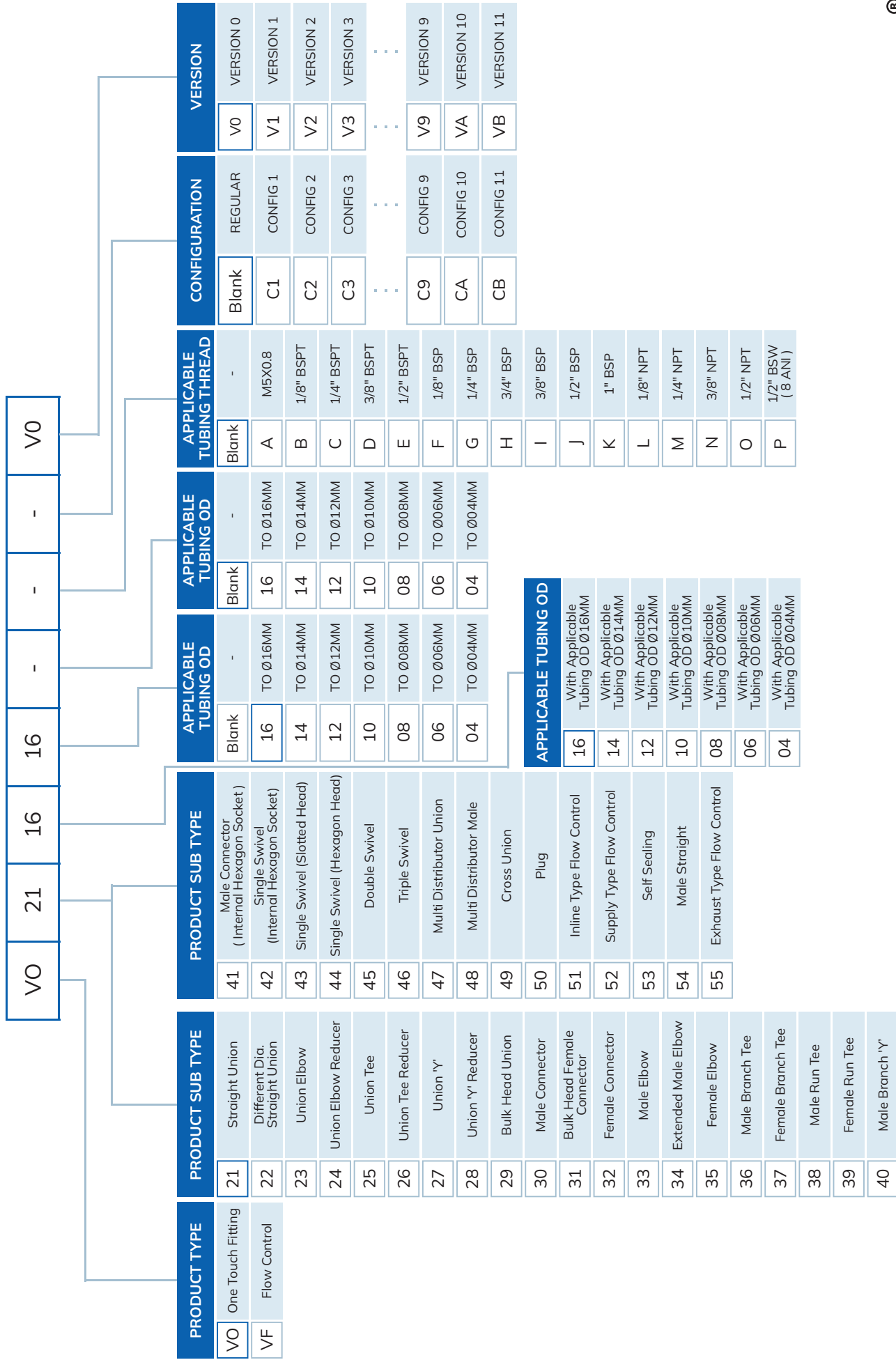

VO211616VO

STRAIGHT UNION TYPE CONNECTOR WITH APPLICABLE TUBING OD Ø16MM TO Ø16MM

Note: The above chart is for identification purposes only, and it may not be possible to make all combinations for the above chart.



PLASTIC TUBINGS
SERIES

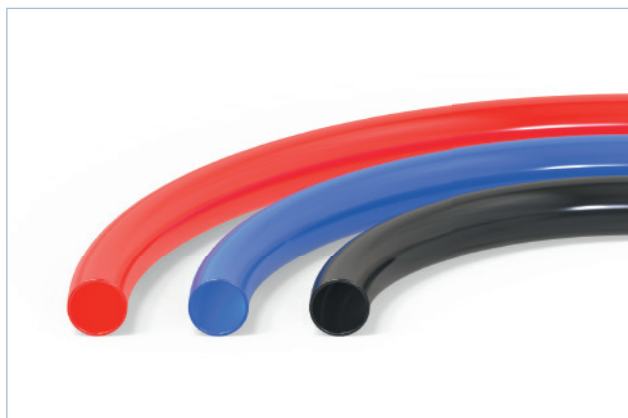

Advantages

Provide differentiation of air line in pneumatic circuits

Usage Instructions

- Cut the tube - end burr free and square, using Tube cutter and clean the edge to ensure leak tight joints. (Do not use blunt tools / hacksaw / chisel etc.,)
- Ensure the tube is fully inserted into the fitting - until the positive stop, beyond the 'U' seal.
- For ensuring proper insertion, pull the tube gently by hand. Polyurethane tube will yield and come out if pulled heavily.
- Minimum bend radius of the tubing to avoid leakage

Recommended Pressure vs Working Temperature

Maximum Pressure :

Ambient temperature :

10 bar	9 bar	8 bar	7 bar
5°C to 30°C	30°C to 40°C	40°C to 50°C	50°C to 60°C

Specification for Polyurethane Tube

Tube OD	Tube ID	Minimum bend radius (in mm)	Blue	Black	Red	Yellow	Silver	Transparent
4	2	10	PS0402B	PS0402K	PS0402R	PS0402Y	PS0402S	PS0402T
6	4	15	PS0604B	PS0604K	PS0604R	PS0604Y	PS0604S	PS0604T
8	5	25	PS0805B	PS0805K	PS0805R	PS0805Y	PS0805S	PS0805T
10	7	30	PS1007B	PS1007K	PS1007R	PS1007Y	PS1007S	PS1007T
12	8	35	PS1208B	PS1208K	PS1208R	PS1208Y	PS1208S	PS1208T
14	10	130	PS1410B	PS1410K	PS1410R	PS1410Y	PS1410S	PS1410T
16	11	140	PS1611B	PS1611K	PS1611R	PS1611Y	PS1611S	PS1611T

Specification for Nylon Tube N6

Tube OD	Tube ID	Minimum bend radius (in mm)	Blue	Black	Red	Yellow	Silver	Transparent
4	2	20	N60402B	N60402K	N60402R	N60402Y	N60402S	N60402T
6	4	40	N60604B	N60604K	N60604R	N60604Y	N60604S	N60604T
8	6	50	N60806B	N60806K	N60806R	N60806Y	N60806S	N60806T
10	8	60	N61008B	N61008K	N61008R	N61008Y	N61008S	N61008T
12	10	80	N61210B	N61210K	N61210R	N61210Y	N61210S	N61210T
14	12	100	N61412B	N61412K	N61412R	N61412Y	N61412S	N61412T

Specification for Nylon Tube N12

Tube OD	Tube ID	Minimum bend radius (in mm)	Blue	Black	Red	Yellow	Silver	Transparent
4	2.5	20	N10425B	N10425K	N10425R	N10425Y	N10425S	N10425T
6	4	40	N10604B	N10604K	N10604R	N10604Y	N10604S	N10604T
8	6	50	N10806B	N10806K	N10806R	N10806Y	N10806S	N10806T
10	8	60	N11008B	N11008K	N11008R	N11008Y	N11008S	N11008T
12	9	80	N11209B	N11209K	N11209R	N11209Y	N11209S	N11209T
14	12	100	N11412B	N11412K	N11412R	N11412Y	N11412S	N11412T

PLASTIC TUBING MODEL IDENTIFICATION CHART

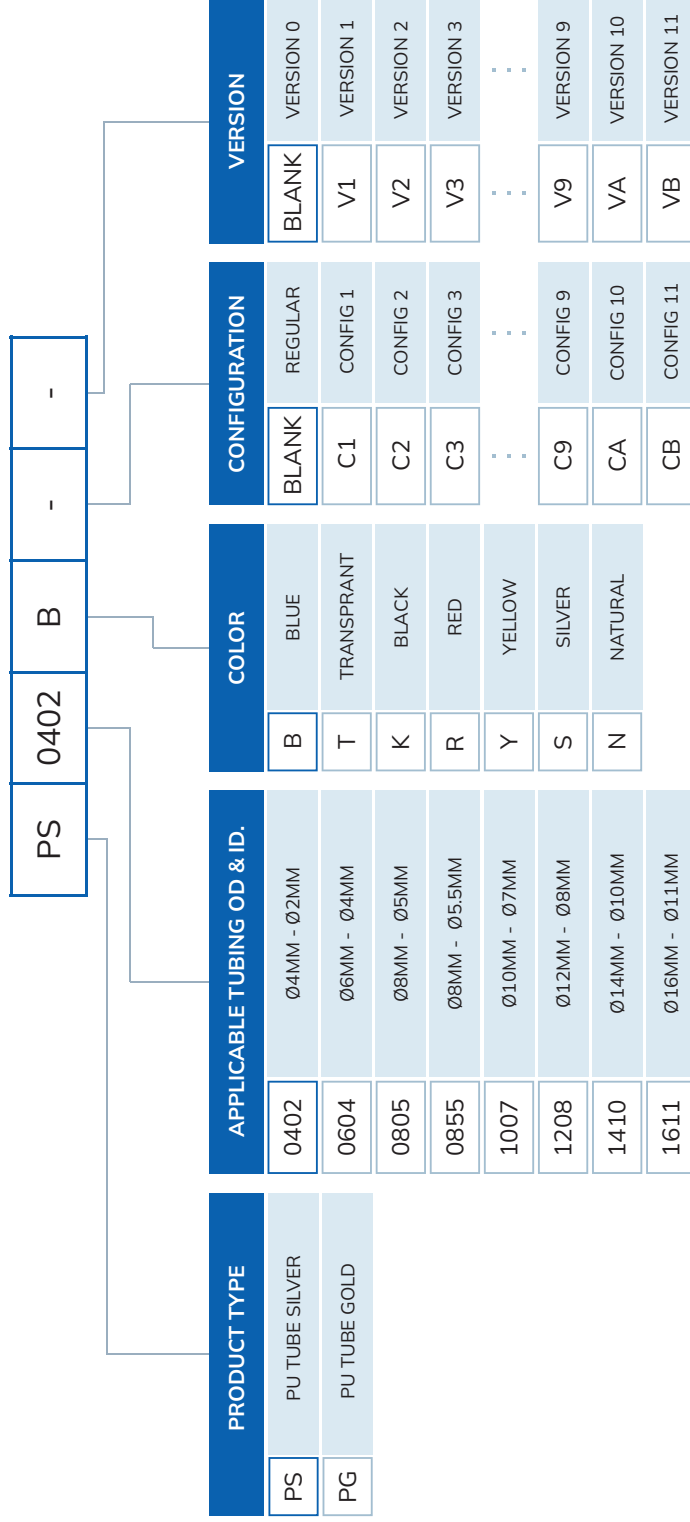

PS0402B
PU TUBE SILVER Ø4MM - Ø2MM - BLUE

Note: The above chart is for identification purposes only, and it may not be possible to make all combinations for the above chart.

NYLON TUBING MODEL IDENTIFICATION CHART

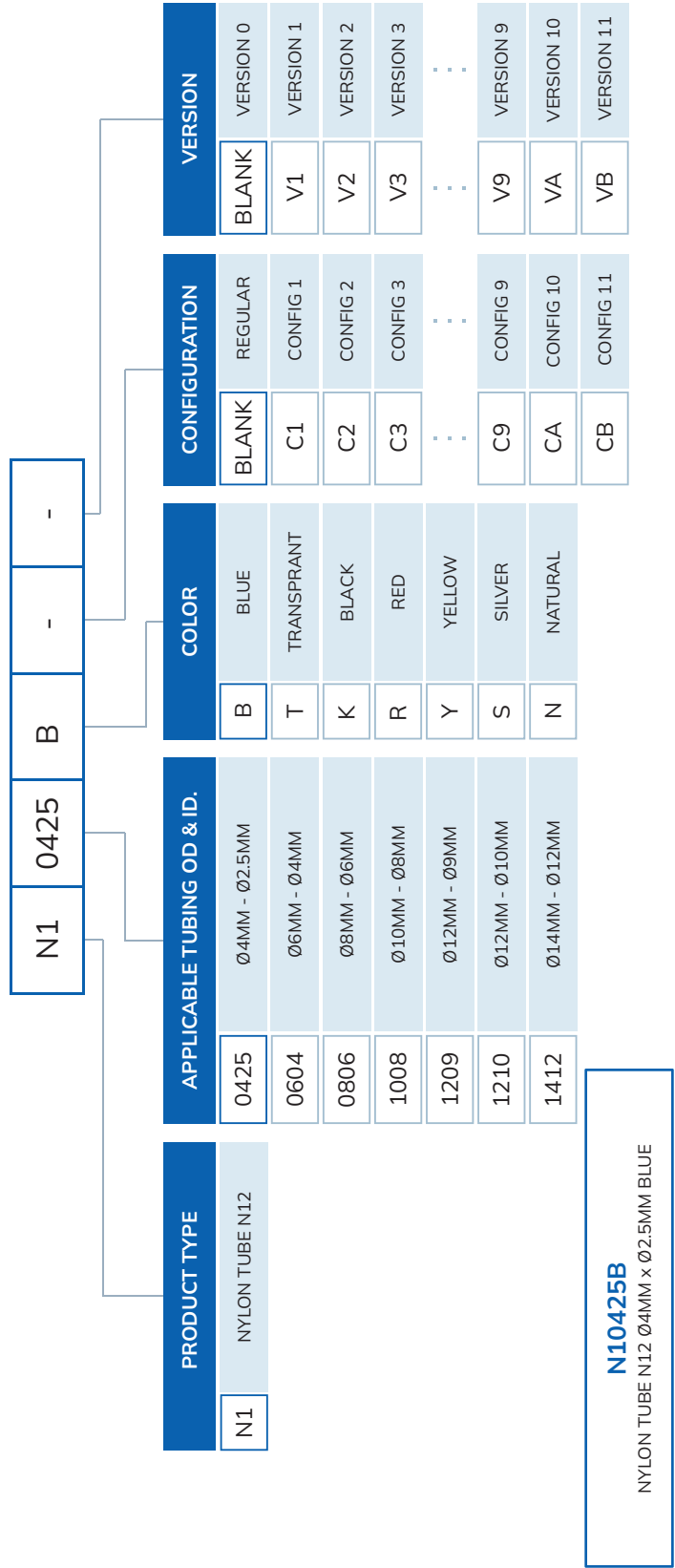
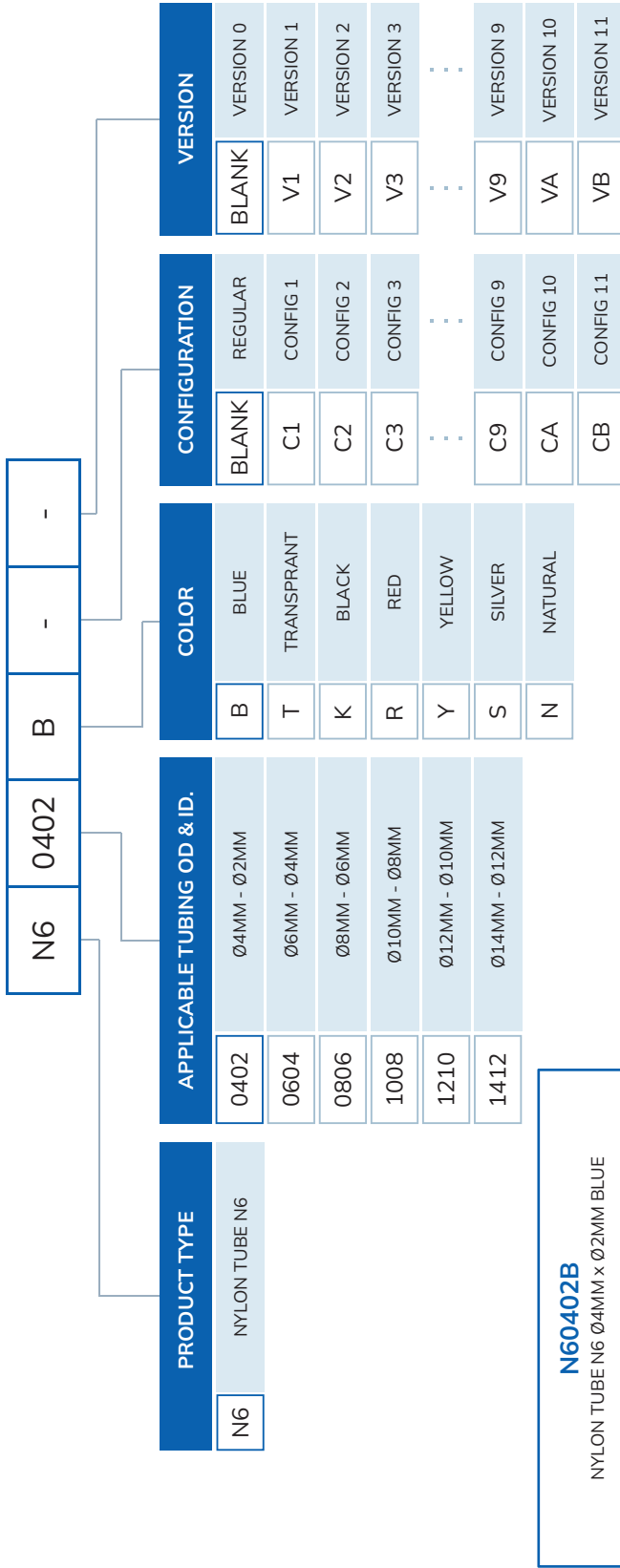

Note: The above chart is for identification purposes only, and it may not be possible to make all combinations for the above chart.



**POPPET VALVE
SERIES**



Valve Specifications

Type :	3/2
Design :	Internal Pilot Operated Poppet Valve
Port Size :	In / Out / Exhaust - 1/4" BSP (Available in NPT)
Media :	Compressed Air (Filtered & Lubricated)
working Pressure Range :	2-10 Bar
Orifice :	7mm
Flow Factor :	18 kv (LPM of Water @ 1 bar ΔP)
Ambient / Media Temperature :	5°C - 60°C
Materials of Construction :	Aluminium, Nitrile, Polymer, Brass

Coil Specification

Operating Voltage :
Power Consumption :

24V AC	110V AC	230V AC	12V DC	24V DC
9W	9W	9W	10W	11W

Coil Features :
Coil Housing :

High Reliability Unaffected by Voltage Surges. Easy coil changes coil lockable in 4X90 position or freely movable in between as require.
IP65 Epoxy square coil, IP65 Metallic round enclosure, IP67 Flameproof Junction box, IP68 Weatherproof enclosure.

Port Connection

1 - Input, 2 - Output, 3 - Exhaust

Model No.	Valve Type	Function	Symbol
CSA1BN23ET070V0	NC	Single Solenoid Spring Return (NC / NO)	
CSA1BN23FT070V0	NO	Single Solenoid Spring Return (NC / NO)	

Features

- Fast response time 600 cycle/min
- Manual override
- 10 Million cycle tested
- Lubrication not essential

Dimension Drawing (All dimensions in mm)

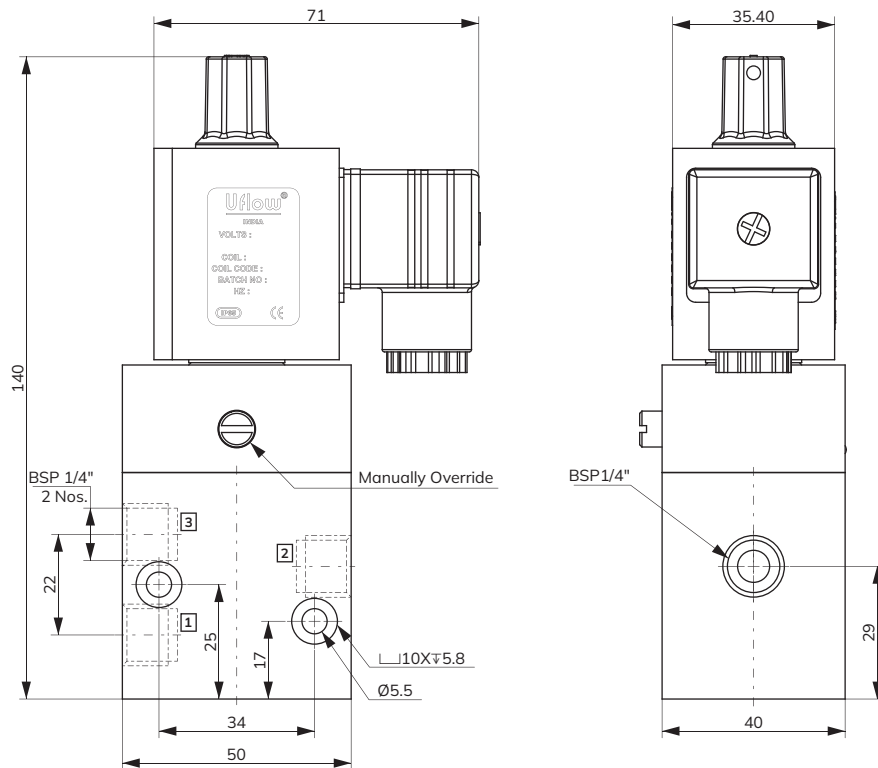



Valve Specifications

Type :	5/2
Design :	Internal Pilot Operated Poppet Valve
Port Size :	In / Out / Exhaust - 1/4" BSP (Available in NPT)
Media :	Compressed Air (Filtered & Lubricated)
working Pressure Range :	2-10 Bar
Orifice :	7mm
Flow Factor :	18 kv (LPM of Water @ 1 bar ΔP)
Ambient / Media Temperature :	5°C - 60°C
Materials of Construction :	Aluminium, Nitrile, Polymer, Brass

Coil Specification

Operating Voltage :

24V AC	110V AC	230V AC	12V DC	24V DC
--------	---------	---------	--------	--------

Power Consumption :

9W	9W	9W	10W	11W
----	----	----	-----	-----

Coil Features :

High Reliability Unaffected by Voltage Surges. Easy coil changes coil lockable in 4X90 position or freely movable in between as require.

Coil Housing :

IP65 Epoxy square coil, IP65 Metallic round enclosure, IP67 Flameproof Junction box, IP68 Weatherproof enclosure.

Port Connection

1 - Input, 2/4 - Output, 3/5 - Exhaust

Model No.	Coil Type	Function	Symbol
CFA1BN23ET070V0	AC	Single Solenoid Spring Return	
CFA1BN23FT070V0	DC		

Features

- Fast response time 1000 cycle/min
- Manual override
- 10 Million cycle tested
- Lubrication not essential

Dimension Drawing (All dimensions in mm)

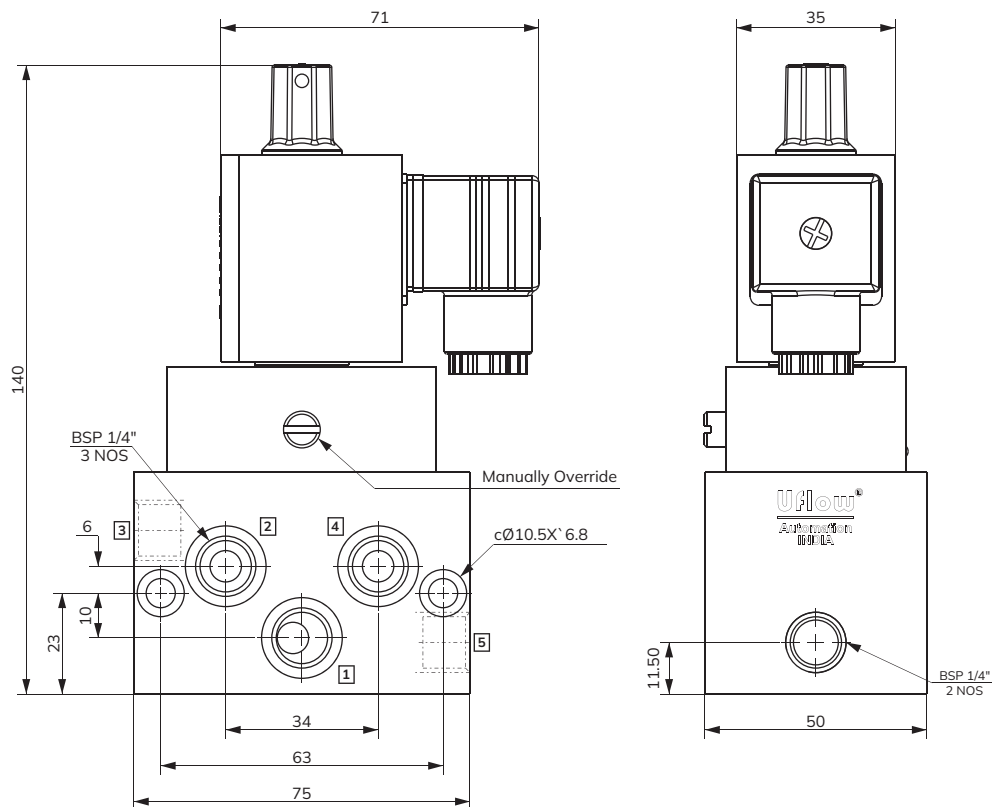



Valve Specifications

Type :	3/2 - 5/2
Design :	Internal Pilot Operated Poppet Valve
Port Size :	In / Exhaust - 1/4" BSP & Out - Namur Hole Pattern (Available in NPT)
Media :	Compressed Air (Filtered & Lubricated)
working Pressure Range :	2-10 Bar
Orifice :	7mm
Flow Factor :	18 kv (LPM of Water @ 1 bar ΔP)
Ambient / Media Temperature :	5°C - 60°C
Materials of Construction :	Aluminium, Nitrile, Polymer, Brass

Coil Specification

Operating Voltage :	24V AC	110V AC	230V AC	12V DC	24V DC
Power Consumption :	9W	9W	9W	10W	11W
Coil Features :	High Reliability Unaffected by Voltage Surges. Easy coil changes coil lockable in 4X90 position or freely movable in between as require.				
Coil Housing :	IP65 Epoxy square coil, IP65 Metallic round enclosure, IP67 Flameproof Junction box, IP68 Weatherproof enclosure.				

Port Connection

1 - Input, 2/4 - Output, 3/5 - Exhaust

Model No.	Coil Type	Function	Symbol
CCA1RN23ET070V0	AC	Single Solenoid Spring Return	5X2
CCA1RN23FT070V0	DC		3X2

Features

- Fast response time 1000 cycle/min
- Manual override
- 10 Million cycle tested
- Lubrication not essential

Dimension Drawing (All dimensions in mm)

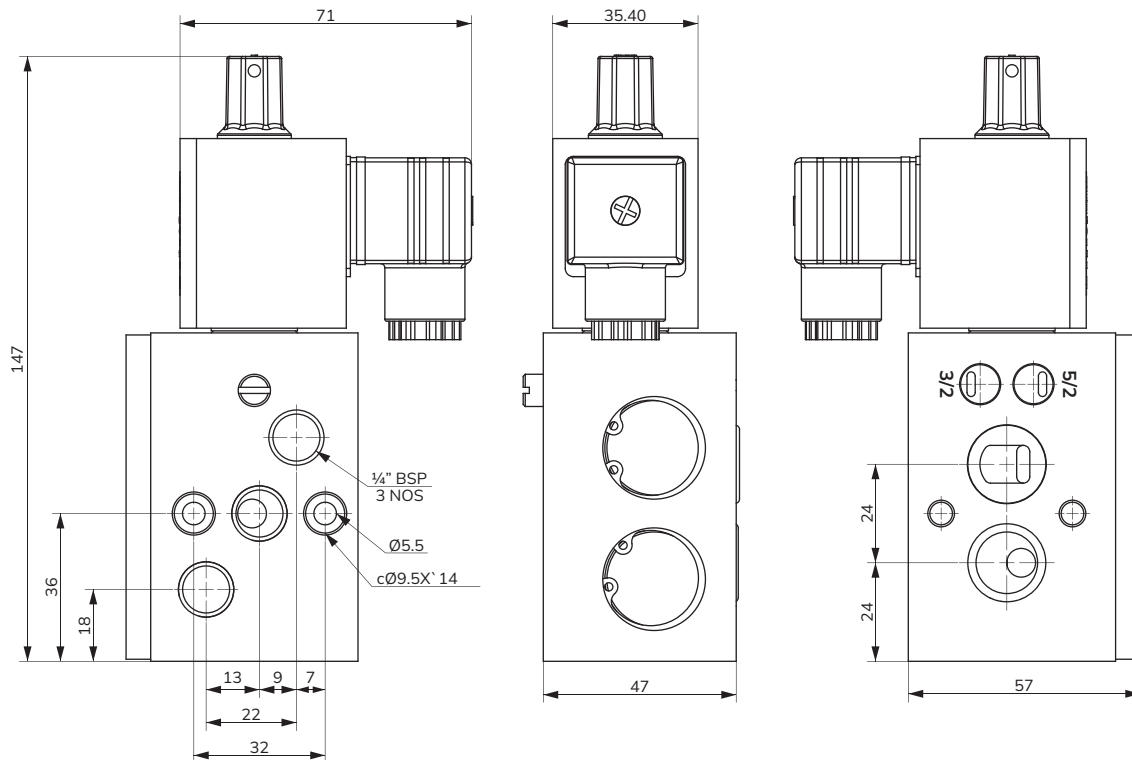



Valve Specifications

Type :	5/2
Design :	Internal Pilot Operated Poppet Valve
Port Size :	In / Out / Exhaust - 1/4" BSP (Available in NPT)
Media :	Compressed Air (Filtered & Lubricated)
working Pressure Range :	2-10 Bar
Orifice :	7mm
Flow Factor :	18 kv (LPM of Water @ 1 bar ΔP)
Ambient / Media Temperature :	5°C - 60°C
Materials of Construction :	Aluminium, Nitrile, Polymer, Brass

Coil Specification

Operating Voltage :
Power Consumption :
Coil Features :
Coil Housing :

24V AC	110V AC	230V AC	12V DC	24V DC
9W	9W	9W	10W	11W

High Reliability Unaffected by Voltage Surges. Easy coil changes coil lockable in 4X90 position or freely movable in between as require.
IP65 Epoxy square coil, IP65 Metallic round enclosure, IP67 Flameproof Junction box, IP68 Weatherproof enclosure.

Port Connection

1 - Input, 2/4 - Output, 3/5 - Exhaust

Model No.	Coil Type	Function	Symbol
CDA1BN23EP060V0	AC	Single Solenoid Spring Return	
CDA1BN23FP060V0	DC		

Features

- Fast response time 1000 cycle/min
- Manual override
- 10 Million cycle tested
- Lubrication not essential

Dimension Drawing (All dimensions in mm)

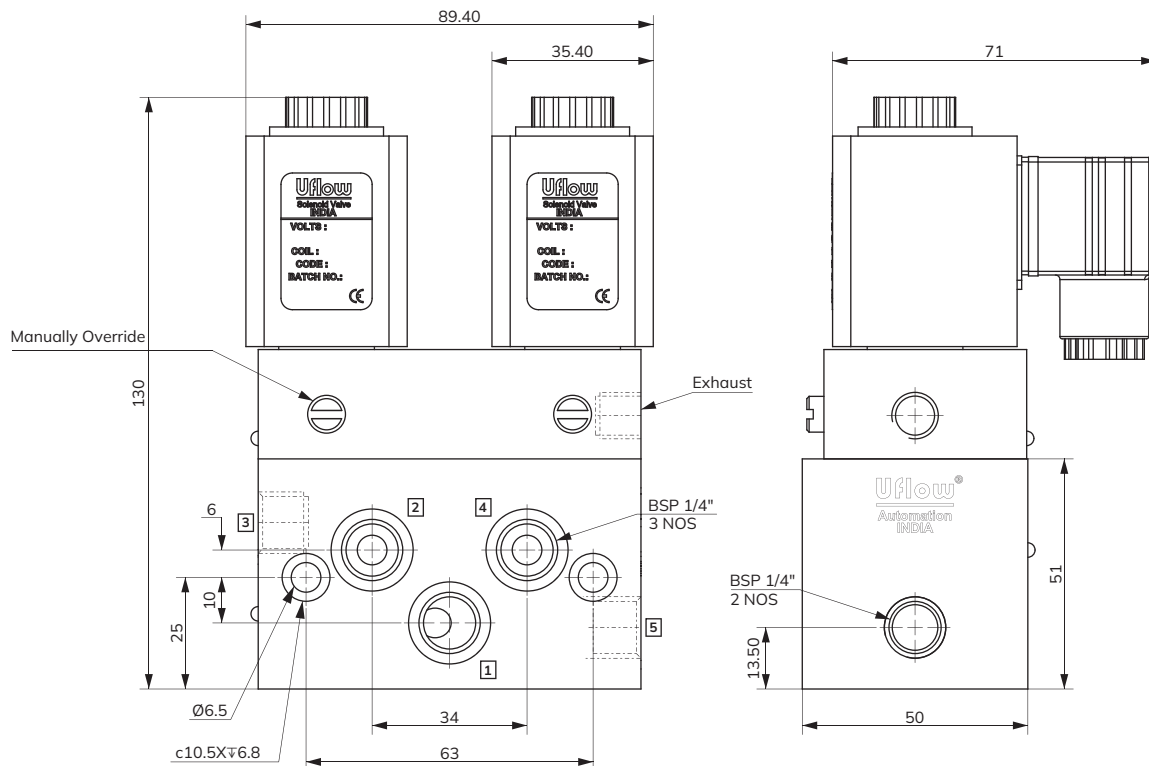



Valve Specifications

Type :	3/2
Design :	Internal Pilot Operated Poppet Valve
Port Size :	In / Out / Exhaust - 1/2" BSP (Available in NPT)
Media :	Compressed Air (Filtered & Lubricated)
working Pressure Range :	2-10 Bar
Orifice :	16mm
Flow Factor :	75 kv (LPM of Water @ 1 bar ΔP)
Ambient / Media Temperature :	5°C - 60°C
Materials of Construction :	Aluminium, Nitrile, Polymer, Brass

Coil Specification

Operating Voltage :	24V AC	110V AC	230V AC	12V DC	24V DC
Power Consumption :	9W	9W	9W	10W	11W
Coil Features :	High Reliability Unaffected by Voltage Surges. Easy coil changes coil lockable in 4X90 position or freely movable in between as require.				
Coil Housing :	IP65 Epoxy square coil, IP65 Metallic round enclosure, IP67 Flameproof Junction box, IP68 Weatherproof enclosure.				

Port Connection

1 - Input, 2 - Output, 3 - Exhaust

Model No.	Coil Type	Function	Symbol
CSA2BN23ET160V0	AC	Single Solenoid	
CSA2BN23FT160V0	DC		

Features

- Fast response time 600 cycle/min
- Manual override
- 10 Million cycle tested
- Lubrication not essential

Dimension Drawing (All dimensions in mm)

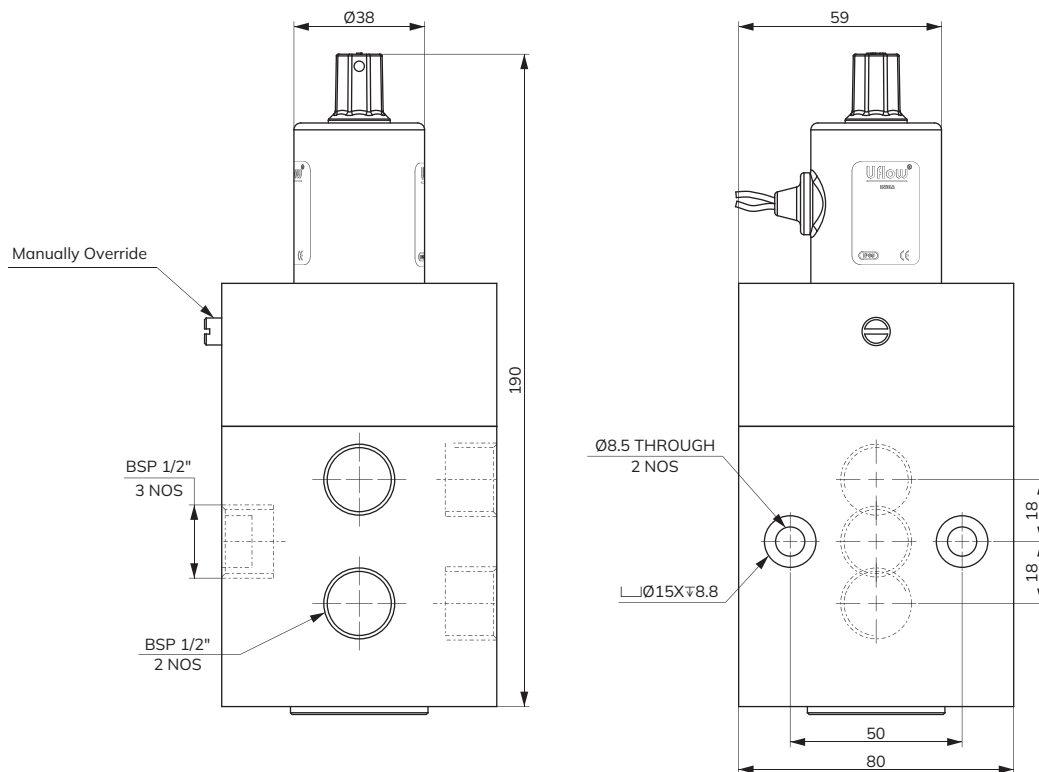



Valve Specifications

Type :	3/2
Design :	3 Way Direct Acting Poppet Type
Port Size :	In / Exhaust - 1/4" BSP & Out - Namur Hole Pattern (Available in NPT)
Media :	Compressed Air (Filtered & Lubricated)
working Pressure Range :	2-10 Bar
Orifice :	7mm
Flow Factor :	18 kv (LPM of Water @ 1 bar ΔP)
Ambient / Media Temperature :	5°C - 60°C
Materials of Construction :	Aluminium, Nitrile, Polymer, Brass

Coil Specification

Operating Voltage :	24V AC	110V AC	230V AC	12V DC	24V DC
Power Consumption :	9W	9W	9W	10W	11W
Coil Features :	High Reliability Unaffected by Voltage Surges. Easy coil changes coil lockable in 4X90 position or freely movable in between as require.				
Coil Housing :	IP65 Epoxy square coil, IP65 Metallic round enclosure, IP67 Flameproof Junction box, IP68 Weatherproof enclosure.				

Port Connection

1 - Input, 2/4 - Output, 3 - Exhaust

Model No.	Coil Type	Function	Symbol
CSA1RN23ET070V0	AC	Single Solenoid Spring Return	
CSA1RN23FT070V0	DC		

Features

- Fast response time 1000 cycle/min
- Manual override
- 10 Million cycle tested
- Lubrication not essential

Dimension Drawing (All dimensions in mm)

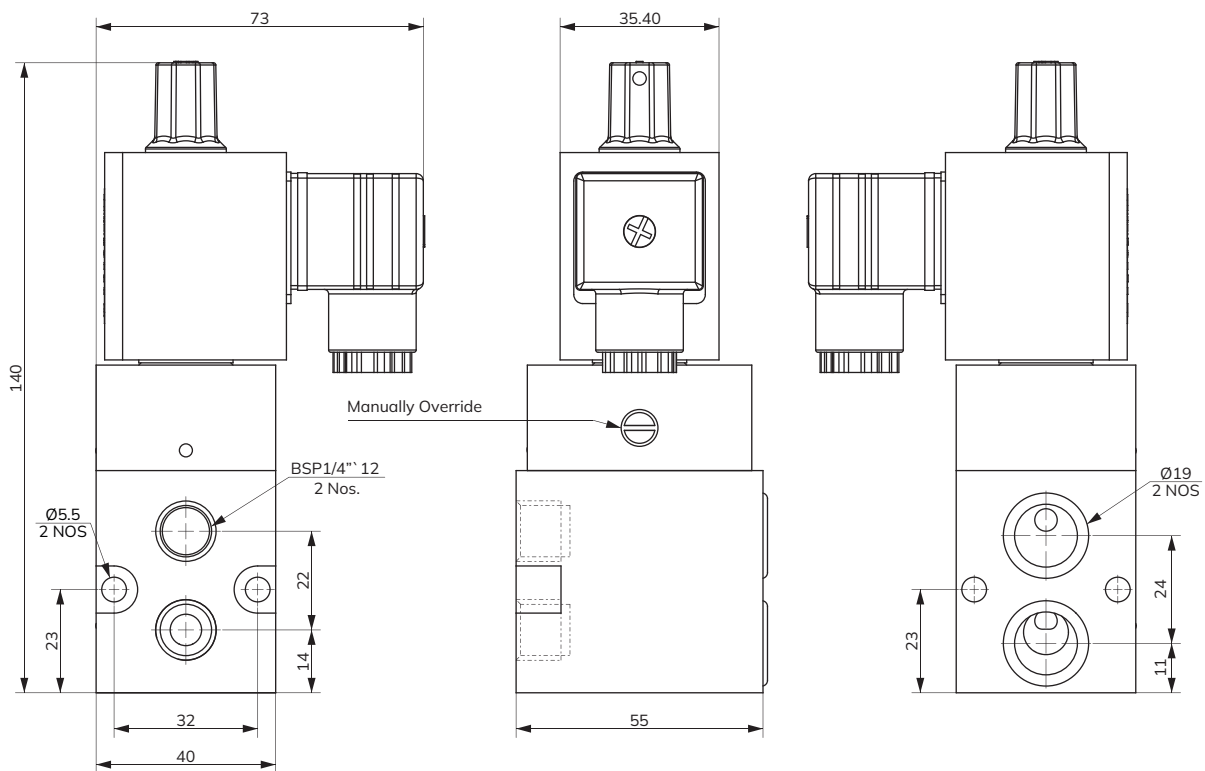



Valve Specifications

Type :	3 Way
Design :	3 Way Direct Acting Poppet Type
Port Size :	In / Out / Exhaust - ¼" BSP (Available in NPT)
Media :	Compressed Air (Filtered & Lubricated)
working Pressure Range :	0-10 Bar
Orifice :	5mm
Flow Factor :	8 kv (LPM of Water @ 1 bar ΔP)
Ambient / Media Temperature :	5°C - 60°C
Materials of Construction :	Aluminium, Nitrile, Polymer, Brass

Coil Specification

Operating Voltage :
Power Consumption :

24V AC	110V AC	230V AC	24V DC
9W	9W	9W	11W

Coil Features :
Coil Housing :

High Reliability Unaffected by Voltage Surges. Easy coil changes coil lockable in 4X90 position or freely movable in between as require.
IP65 Epoxy square coil, IP65 Metallic round enclosure, IP67 Flameproof Junction box, IP68 Weatherproof enclosure.

Port Connection

1 - Input, 2/4 - Output, 3 - Exhaust

Model No.	Coil Type	Function	Symbol
TAN104RNGT050V0	AC	Single Solenoid Spring Return	
TAN104RNHT050V0	DC		

Features

- Fast response time 1000 cycle/min
- Manual override
- 10 Million cycle tested
- Lubrication not essential

Dimension Drawing (All dimensions in mm)

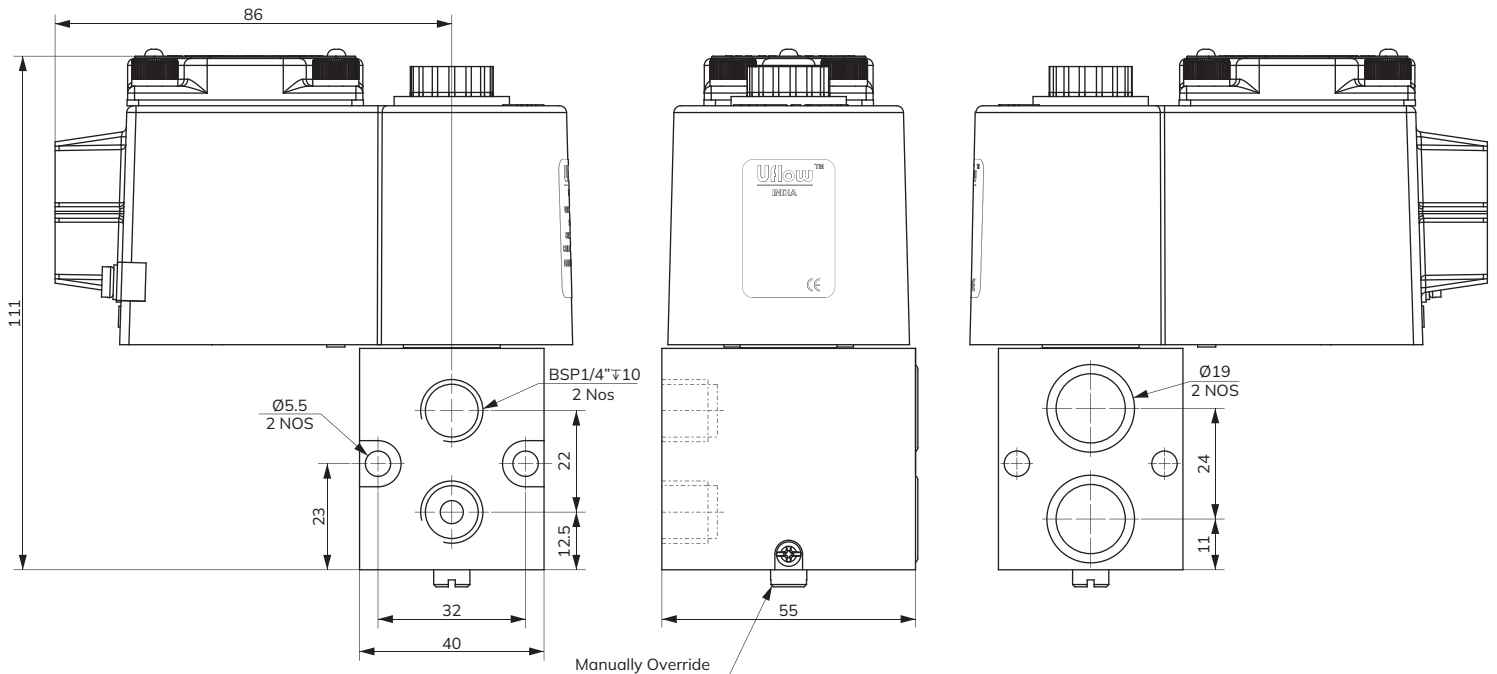



Valve Specifications

Type :
 Design :
 Port Size :
 Media :
 working Pressure Range :
 Orifice :
 Flow Factor :
 Ambient / Media Temperature :
 Materials of Construction :

3 Way	
3 Way Direct Acting Poppet Type	
In / Out / Exhaust - ¼" BSP	In / Out / Exhaust - ½" BSP
Compressed Air (Filtered & Lubricated)	
0-10 Bar	
7mm	10mm
14 kv (LPM of Water @ 1 bar ΔP)	30 kv (LPM of Water @ 1 bar ΔP)
5°C - 60°C	
Aluminium, Nitrile, Polymer, Brass	

Coil Specification

Operating Voltage :
 Power Consumption :
 Coil Features :
 Coil Housing :

24V AC	110V AC	230V AC	12V DC	24V DC
9W	9W	9W	10W	11W

High Reliability Unaffected by Voltage Surges. Easy coil changes coil lockable in 4X90 position or freely movable in between as require.
 IP65 Epoxy square coil, IP65 Metallic round enclosure, IP67 Flameproof Junction box, IP68 Weatherproof enclosure.

Port Connection

1 - Input, 2 - Output, 3 - Exhaust

Model No.	Coil Type	Function	Symbol
TAN204BNIT100V0	AC	Single Solenoid Spring Return	
TAN204BNJT100V0	DC		

Features

- Fast response time 1000 cycle/min
- Manual override
- 10 Million cycle tested
- Lubrication not essential

Dimension Drawing (All dimensions in mm)

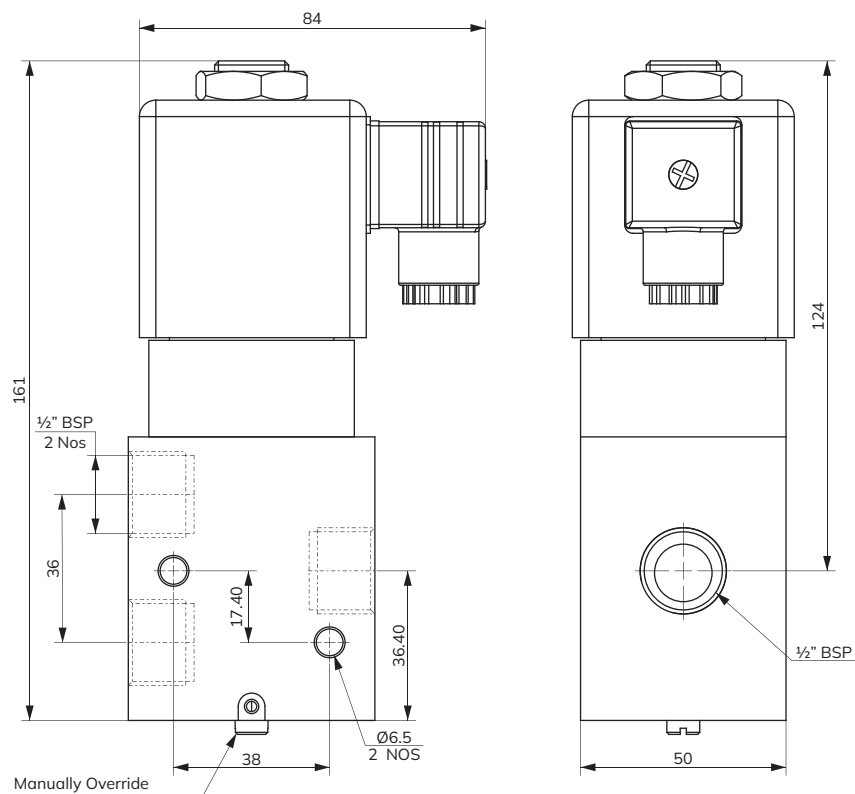

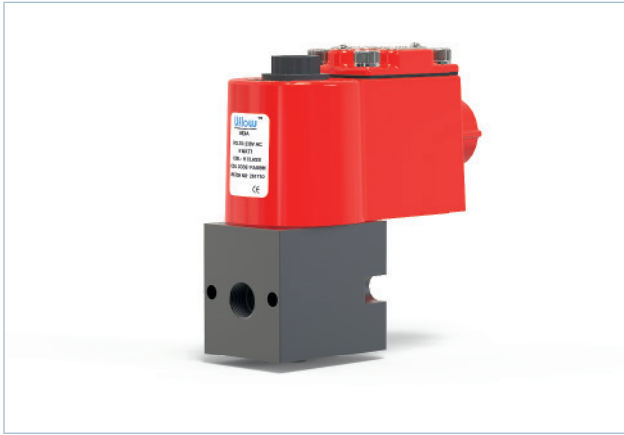

Valve Specifications

Type :	3 Way
Design :	3 Way Direct Acting Poppet Type
Port Size :	In / Out / Exhaust - ¼" BSP (Available in NPT)
Media :	Compressed Air (Filtered & Lubricated)
working Pressure Range :	0-10 Bar
Orifice :	5mm
Flow Factor :	8 kv (LPM of Water @ 1 bar ΔP)
Ambient / Media Temperature :	5°C - 60°C
Materials of Construction :	Aluminium, Nitrile, Polymer, Brass

Coil Specification

Operating Voltage :	24V AC	110V AC	230V AC	24V DC
Power Consumption :	9W	9W	9W	11W
Coil Features :	High Reliability Unaffected by Voltage Surges. Easy coil changes coil lockable in 4X90 position or freely movable in between as require.			
Coil Housing :	IP65 Epoxy square coil, IP65 Metallic round enclosure, IP67 Flameproof Junction box, IP68 Weatherproof enclosure.			

Port Connection

1 - Input, 2 - Output, 3 - Exhaust

Model No.	Coil Type	Function	Symbol
TAN104BUGT050V0	AC	Single Solenoid Spring Return	
TAN104BUHT050V0	DC		

Features

- Fast response time 1000 cycle/min
- Manual override
- 10 Million cycle tested
- Lubrication not essential
- Universal Type (NO/NC)

Dimension Drawing (All dimensions in mm)

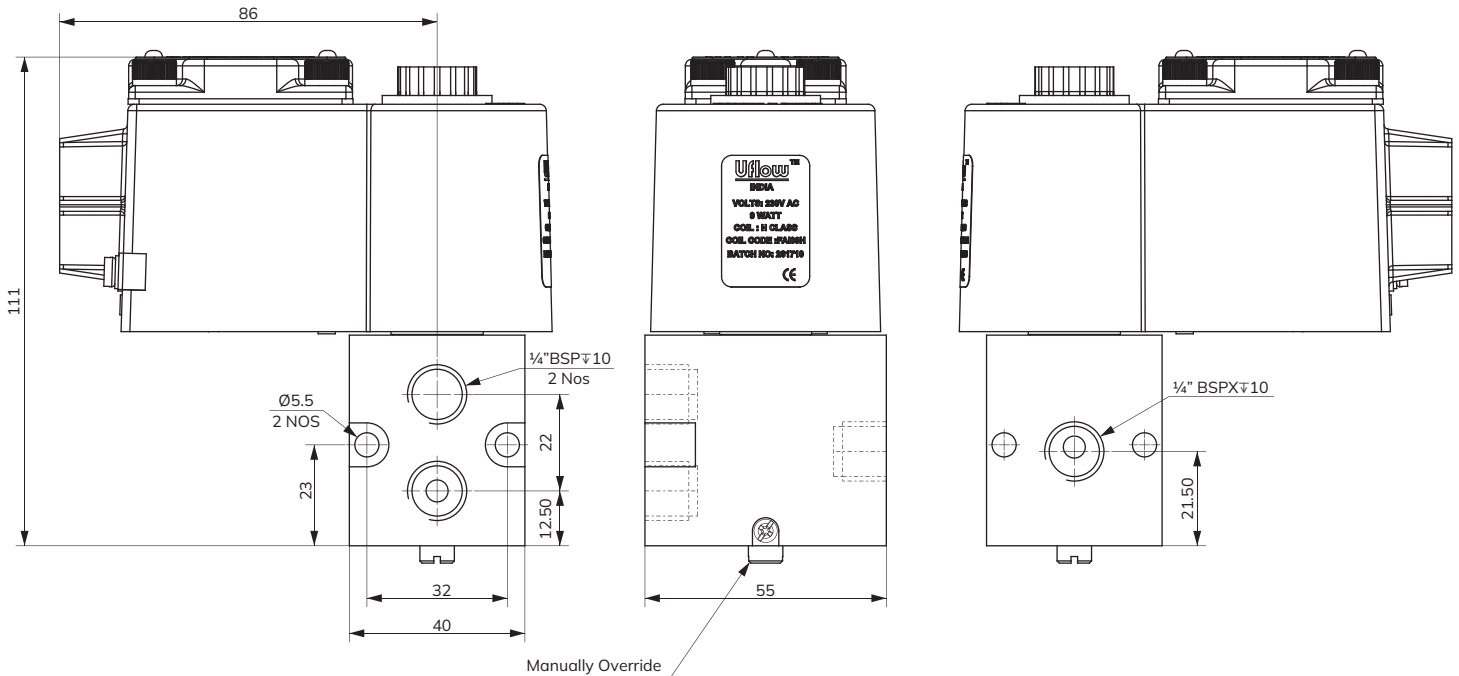

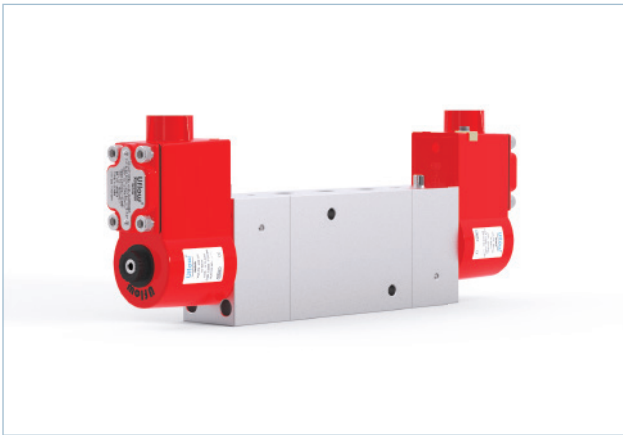

Valve Specifications

Type :	5x2
Design :	Internal Pilot Operated Poppet Valve
Port Size :	In / Out / Exhaust - ½" BSP (Available in NPT)
Media :	Compressed Air (Filtered & Lubricated)
working Pressure Range :	2-10 Bar
Orifice :	12 mm
Flow Factor :	50 kv (LPM of Water @ 1 bar ΔP)
Ambient / Media Temperature :	5°C - 60°C
Materials of Construction :	SS316, Nitrile, Polymer

Coil Specification

Operating Voltage :	24V AC	110V AC	230V AC	24V DC
Power Consumption :	9W	9W	9W	11W
Coil Features :	High Reliability Unaffected by Voltage Surges. Easy coil changes coil lockable in 4X90 position or freely movable in between as require.			
Coil Housing :	IP67 Flameproof Junction box			

Port Connection

1 - Input, 2/4 - Output, 3/5 - Exhaust

Valve Model No.	Coil Type	Function	Symbol
HD62BN23GP120V0	AC	Double Solenoid	
HD62BN23HP120V0	DC		

Features

- Fast response time 1000 cycle/min
- Manual override
- 20 Million cycle tested
- Lubrication not essential
- Suitable for high speed cycling
- Life > 20 Million Cycle

Dimension Drawing (All dimensions in mm)

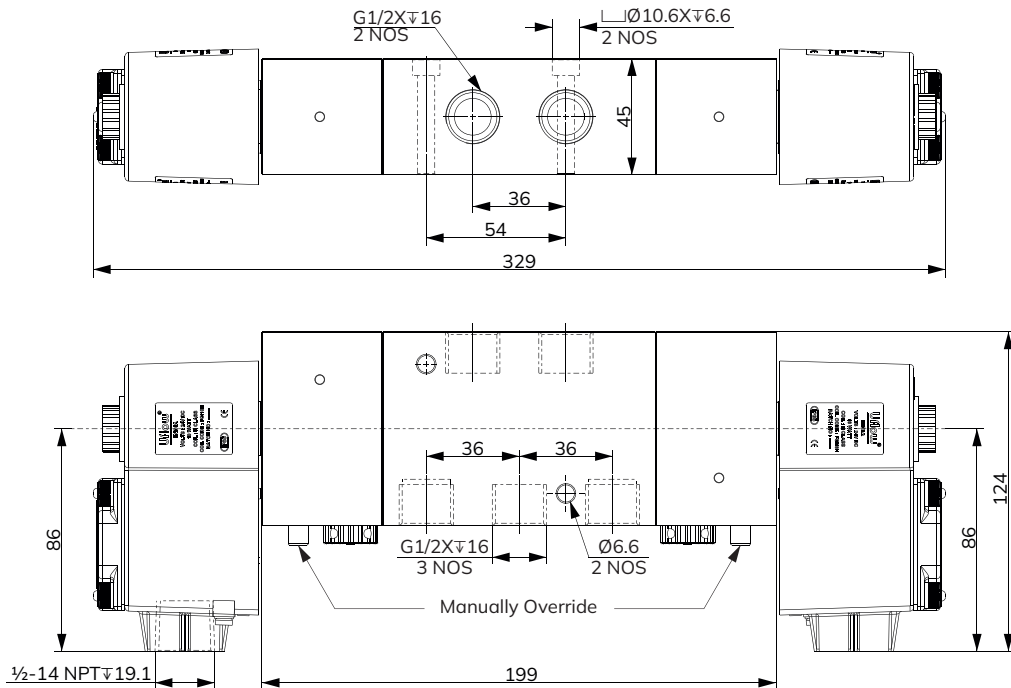

DC SOLENOID POPPET TYPE VALVE MODEL IDENTIFICATION CHART

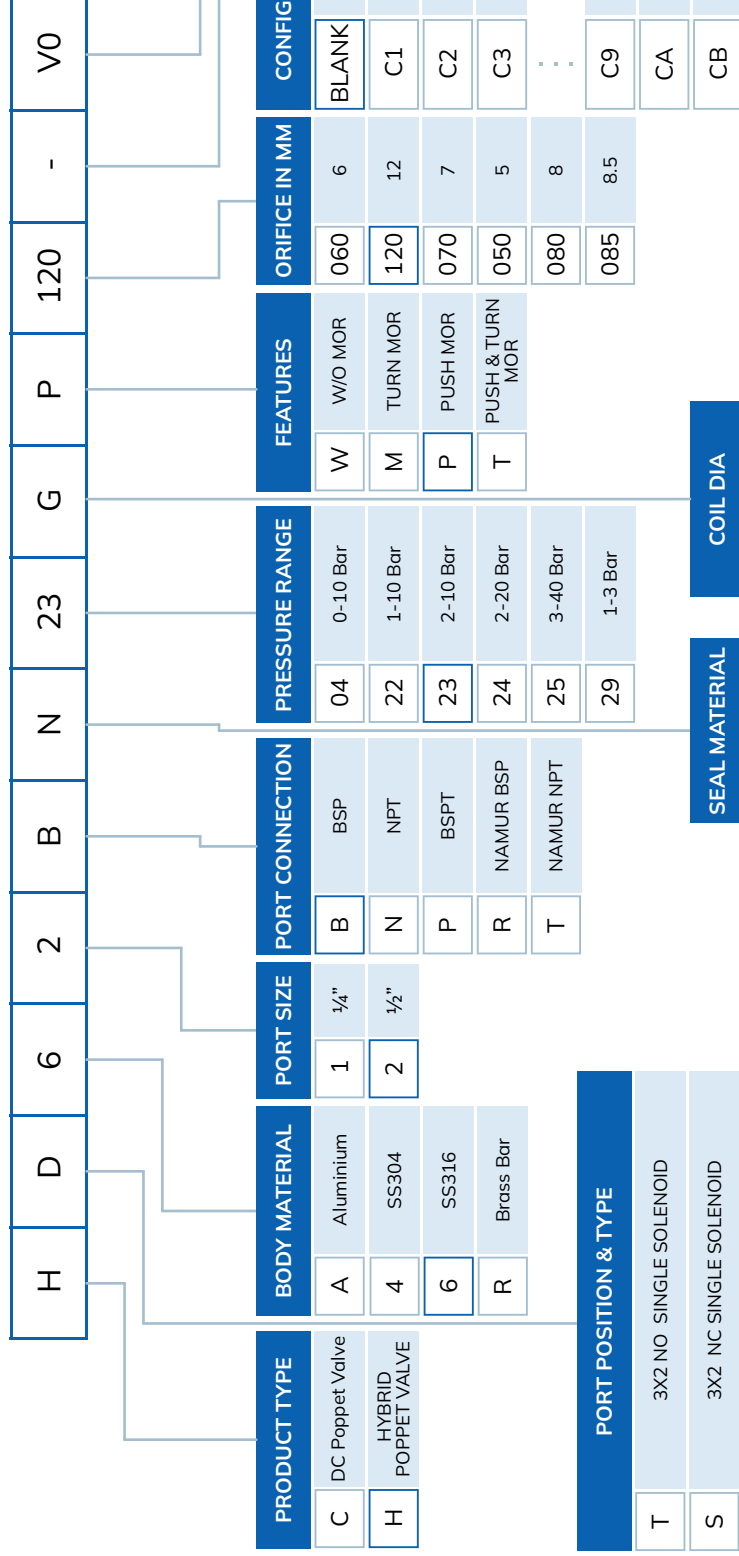

PORT POSITION & TYPE	SEAL MATERIAL	COIL DIA
T 3X2 NO SINGLE SOLENOID	N Nitrile	E 14MM AC
S 3X2 NC SINGLE SOLENOID	V VITON	F 14MM DC
F 5X2 SINGLE SOLENOID	S SILICONE	G 14MM FLP AC
D 5X2 DOUBLE SOLENOID	C FLUORO SILICONE	H 14MM FLP DC
B 5X3 CENTER BLOCKED		I 18MM AC
E 5X3 CENTER EXHAUSTED		J 18MM DC
P 5X3 CENTER PRESSURISED		V 18MM FLP AC
A 4X2 SINGLE SOLENOID		W 18MM FLP DC
U 4X2 DOUBLE SOLENOID		
C 3X2 & 5X2 SINGLE SOLENOID CONVERTIBLE		
V 3X2 NC DOUBLE SOLENOID		

1/2" 5X2 DOUBLE SOLENOID DC HYBRID POPPET VALVE SS316-BSP-NITRILE-2 TO 10 Bar-14MM FLP AC-PUSH MOR-12MM ORIFICE
HD62BN23GP120V0

Note: The above chart is for identification purposes only, and it may not be possible to make all combinations for the above chart.

3 WAY DIRECT ACTING POPPET TYPE VALVE MODEL IDENTIFICATION CHART

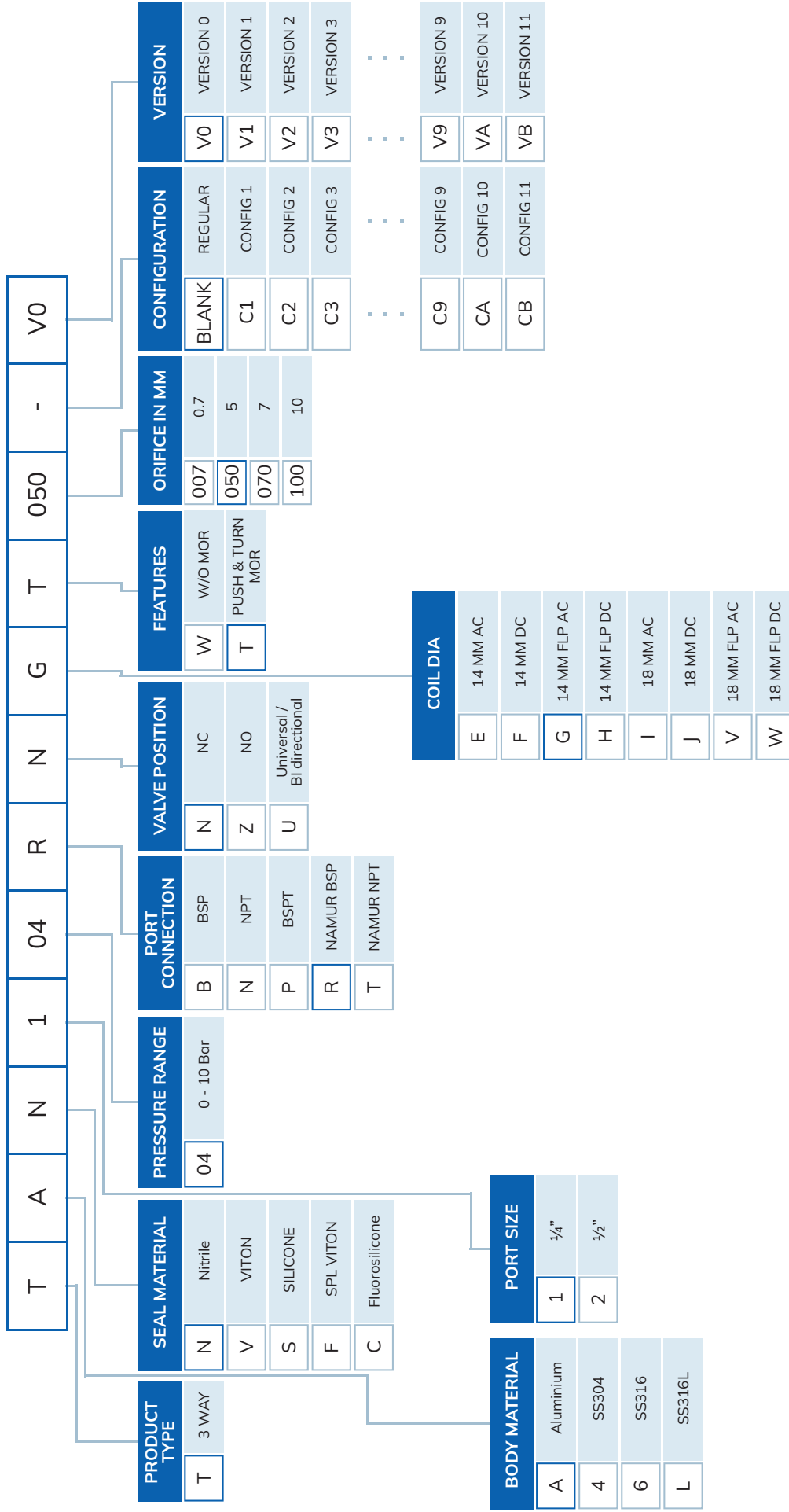

TAN104RNGT050V0
 1/4" 3 WAY DIRECT ACTING ALUMINIUM-NITRILE-0 TO 10 Bar-NAMUR BSP-NC-14MM FLP AC-PUSH & TURN MOR-5MM ORIFICE

Note: The above chart is for identification purposes only, and it may not be possible to make all combinations for the above chart.



Valve Specifications

Type :	3/2
Design :	External Pilot Operated, Poppet Type
Port Size :	G 1/2" BSP Female
Media :	Compressed Air (Filtered & Lubricated)
Seals:	Nitrile Rubber
Orifice:	13mm
Temperature Range:	5°C to 50°C
Mainline Pressure Range:	3 to 20 bar
External Pilot Pressure Range:	5 to 9 bar
Flow (NLPM) at 5 bar	3600 Normal Litres Per Min.
Coil Voltage:	AC: 24V, 110V, 230V DC: 12V, 24V, 36V, 48V, 110V
Power:	AC: 6W DC: 6W
Duty Cycle:	Continuous
Response Time:	15 msec ON / 25 msec OFF
Protection:	IP65
Other Specification Data:	Available on Request

Port Connection

1 - Input, 2 - Output, 3 - Exhaust, 8 - Pilot In

Model No.	Diagram No.	Symbol
CSA2BN40CW130V0	1.1	
CVA2BN40CW130V0	1.2	

3/2 High Pressure Blow Solenoid Poppet Valve

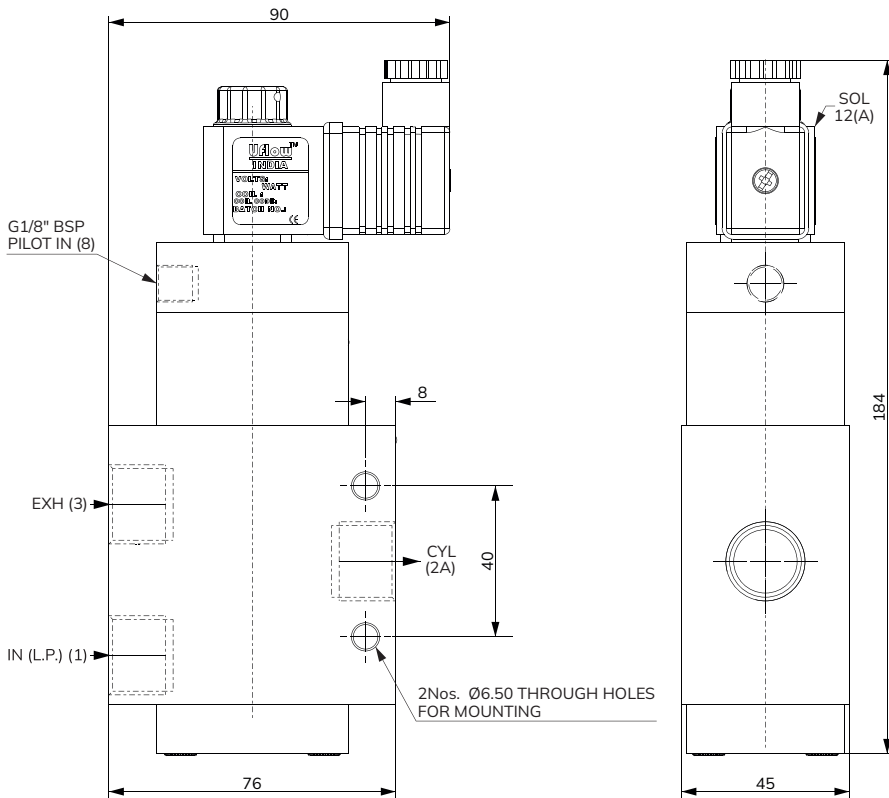

Diagram No. : 1.1



3/2 Dual Pressure Blow Solenoid Poppet Valve

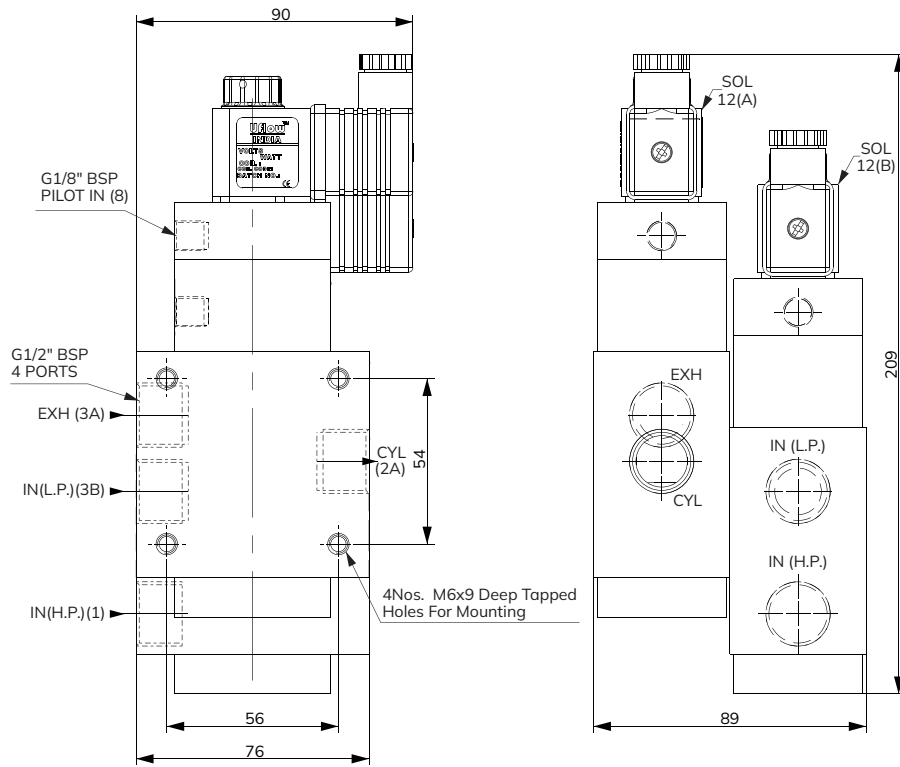

Diagram No. : 1.2



Sequence Of Operation

- SOL 12A 'ON' : Low Pressure (3B) is connected to outlet (Cyl 2A) (Low Pressure pre-blow)
- SOL 12A + SOL 12B 'ON' : High Pressure is connected to outlet (Cyl 2A) (High Pressure blow)
- Both SOL 'OFF' : Outlet (Cyl 2A) connected to Exh (3A) (Exhausting)

DC SOLENOID POPPET TYPE VALVE MODEL IDENTIFICATION CHART

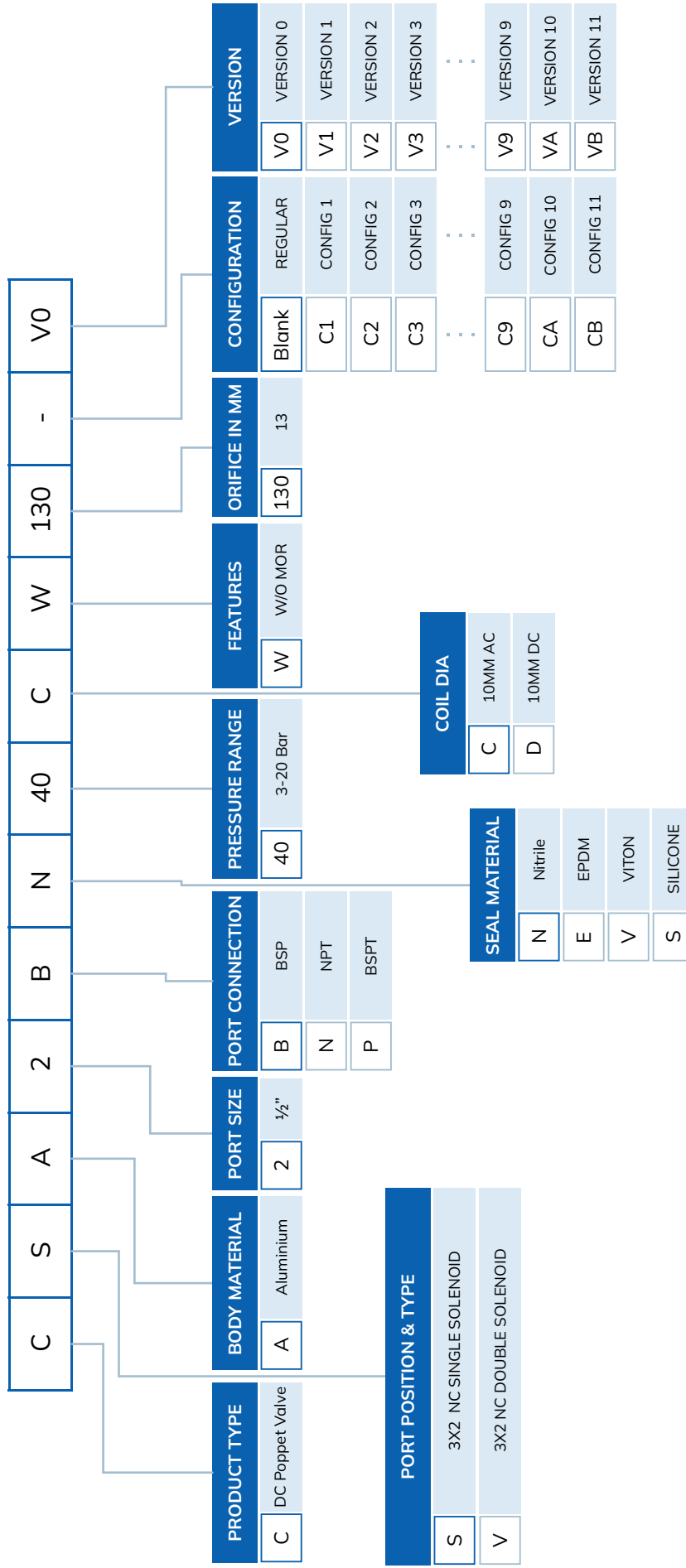

CSA2BN40CW130V0
1/2" 3X2 NC SINGLE SOLENOID DC POPPET VALVE ALUMINIUM-BSP-NITRILE-3 TO 20 BAR-10MM AC-13MM ORIFICE



SOLENOID VALVE SERIES

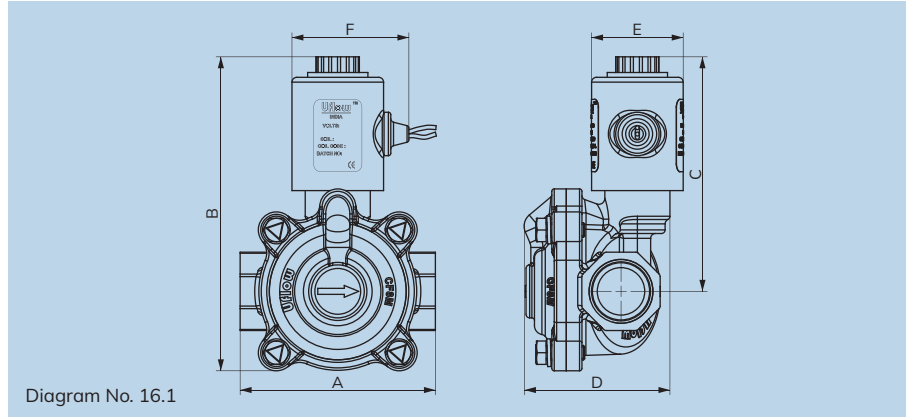
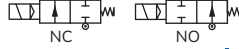

Diagram No. 16.1



Specifications

Port :	3/8", 1/2", 3/4", 1", 1 1/4", 1 1/2", 2", 2 1/2", 3" & 4" (Available BSP / NPT)				
End Connection :	Screwed / Flange				
Body Material :	SS ASTM A351 Grade CF8 / CF8M				
Diaphragm :	Nitrile (NBR)	EPDM	Viton (FKM)		
Media Temp :	-30°C to 90°C	-10°C to 140°C	-10°C to 180°C		
Circumstance Temp :	-10°C to 70°C				
Media :	Air, Water, Chemical, Gas, Oil & LPG				
Main Features :	Internal Parts are in superior corrosion resistance steel, (Equivalent to SS316L) Suitable for Food Industries, Pharmaceuticals, Chemical application & Highly corrosive environment.				
Operating Voltage :	24AC	110AC	230AC	12DC	24DC
Power Consumption :	9W	9W	9W	10W	11W
Coil Features :	High Reliability Unaffected by Voltage Surges. Easy coil changes coil lockable in 4X90 position or freely movable in between as require.				
Coil Housing :	IP65 Epoxy square coil, IP65 Metallic round enclosure, IP67 Flameproof enclosure, IP68 Weatherproof enclosure.				
Optional Feature :	90% Power saver series also available, Manual Override, Water hammering reducer also available to avoid water hammer forces.				
Other Specification Data :	Available on Request. - High Pressure 20Kg Series. - Manual Override				

NOTE: Use of filter in the inlet port is recommended.

Dimension - NC (All dimensions in mm)

All dimensions are approx.

Model No.	Port Size	Diagram No.	A	B	C	D	E	F
PCN708BNEWV0	3/8"	16.1	67	123	95	52	38	49
PCN208BNEWV0	1/2"	16.1	67	123	95	52	38	49
PCN308BNEWV0	3/4"	16.1	81	130	97	60	38	49
PCN408BNEWV0	1"	16.1	96	146	105	66	38	49
PCN508BNEWV0	1 1/4"	16.1	108	154	108	88	38	49
PCN608BNEWV0	1 1/2"	16.1	108	154	108	88	38	49
PCN808BNEWV0	2"	16.1	132	181	126	102	38	49
PCN908BNEWV0	2 1/2"	16.1	166	212	140	126	38	49
PCNA08BNEWV0	3"	16.1	192	237	151	138	38	49
PCNB08BNIWV0	4"	16.1	262	257	194	202	50	63

In normally open valve dimension B&C will increase up to 8mm.

Section View

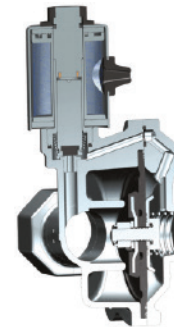

Technical Data

Model No.	Body Material	Pipe (Inch)	Orifice (mm)	Min. Operating Pressure Kg/cm ²	Max. Operating Pressure Kg/cm ²	Seal & Diaphragm Material	Flow Factor Kv m ³ / hr
PCN708BNEWV0	CF8 / CF8M	3/8"	15	0.5	12	NBR / EPDM / VITON	2
PCN208BNEWV0	CF8 / CF8M	1/2"	17	0.5	12	NBR / EPDM / VITON	4.4
PCN308BNEWV0	CF8 / CF8M	3/4"	20	0.5	12	NBR / EPDM / VITON	3.7
PCN408BNEWV0	CF8 / CF8M	1"	25	0.5	12	NBR / EPDM / VITON	10
PCN508BNEWV0	CF8 / CF8M	1 1/4"	36	0.5	12	NBR / EPDM / VITON	12.2
PCN608BNEWV0	CF8 / CF8M	1 1/2"	36	0.5	12	NBR / EPDM / VITON	17.1
PCN808BNEWV0	CF8 / CF8M	2"	47	0.5	12	NBR / EPDM / VITON	33.3
PCN908BNEWV0	CF8 / CF8M	2 1/2"	59	0.5	12	NBR / EPDM / VITON	43.5
PCNA08BNEWV0	CF8 / CF8M	3"	71	0.5	12	NBR / EPDM / VITON	64.5
PCNB08BNIWV0	CF8 / CF8M	4"	98	0.5	12	NBR / EPDM / VITON	115

PILOT OPERATED DIAPHRAGM TYPE SOLENOID VALVE MODEL IDENTIFICATION CHART

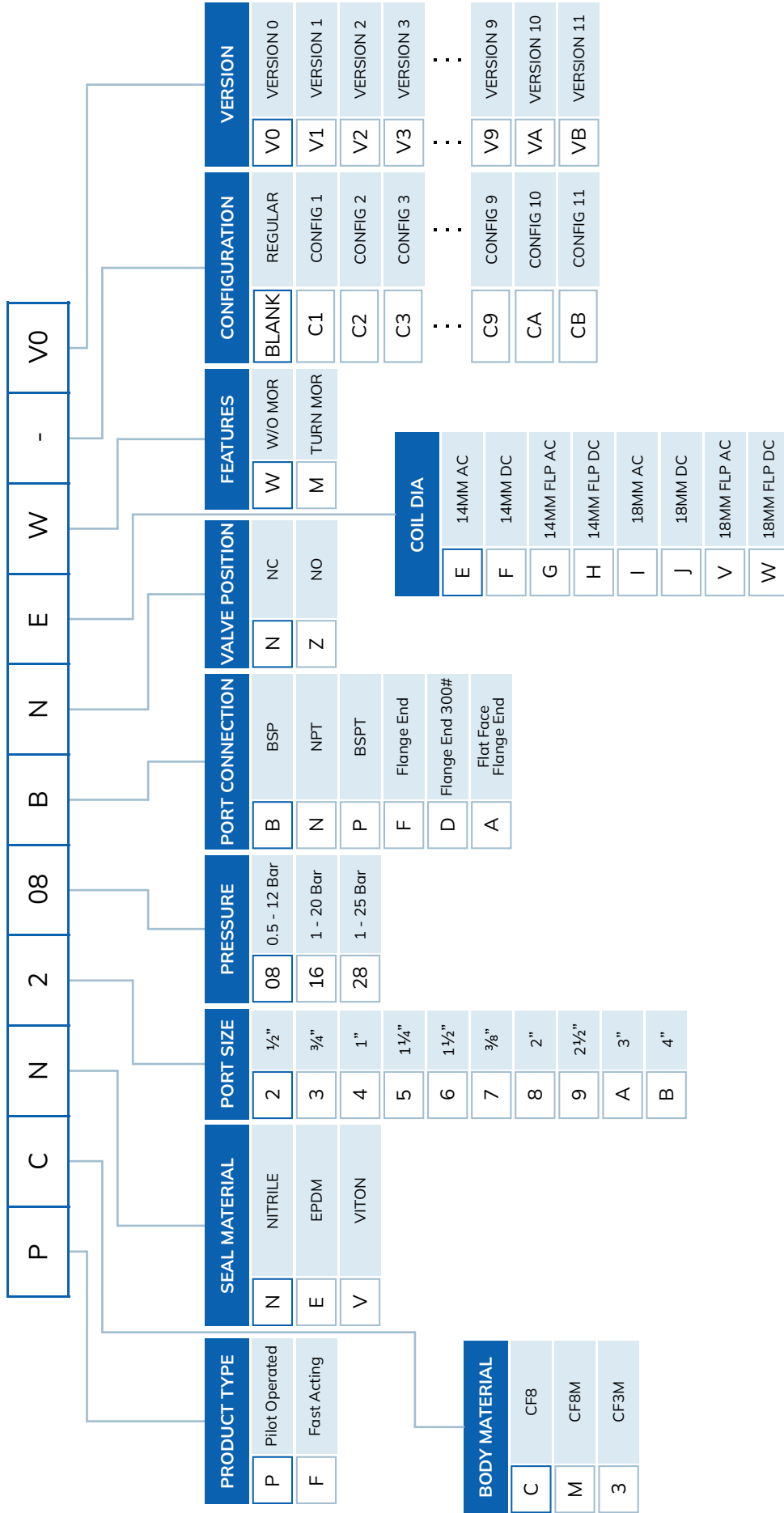

PCN208BNEWV0
1/2" PILOT OPERATED DIAPHRAGM CF8-NITRILE-0.5 TO 12 Bar-BSP-NC-14MM AC



Note: The above chart is for identification purposes only, and it may not be possible to make all combinations for the above chart.

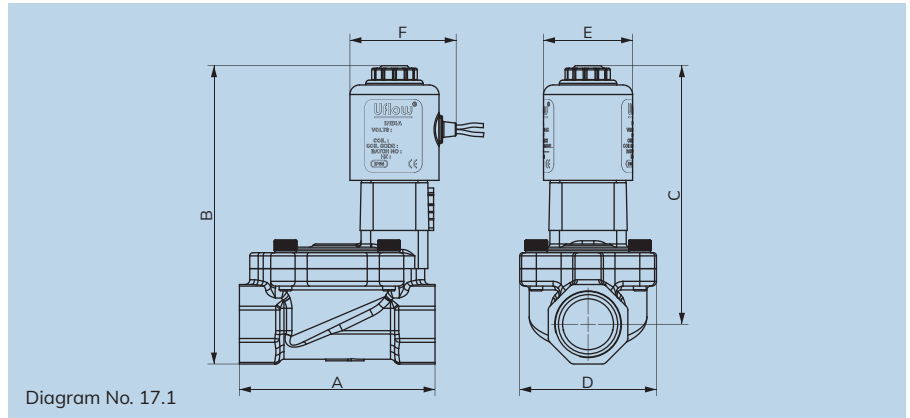
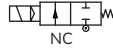

Diagram No. 17.1



Specifications

Port :	3/8", 1/2", 3/4", 1", 1 1/2" & 2" (Available BSP / NPT)			
End Connection :	Screwed			
Body Material :	Forged Brass			
Diaphragm :	Nitrile (NBR)	EPDM	Viton (FKM)	
Media Temp :	-30°C to 90°C	-10°C to 140°C	-10°C to 180°C	
Circumstance Temp :	-10°C to 70°C			
Media :	Air, Water, Chemical, Gas, Oil, Diesel, Kerosene, LPG.			
Main Features :	Internal Parts are in superior corrosion resistance steel, (Equivalent to SS316L) Suitable for Food Industries, Pharmaceuticals, Chemical application & Highly corrosive environment.			
Operating Voltage :	24AC	110AC	230AC	12DC
Power Consumption :	9W / 6W	9W / 6W	9W / 6W	10W / 6W
Coil Features :	High Reliability Unaffected by Voltage Surges. Easy coil changes coil lockable in 4X90 position or freely movable in between as require.			
Coil Housing :	IP65 Epoxy square coil, IP65 Metallic round enclosure, IP68 Weatherproof enclosure.			
Optional Feature :	90% Power saver series also available, Manual Override, Water hammering reducer also available to avoid water hammer forces.			
Other Specification Data :	Available on Request.			

NOTE: Use of filter in the inlet port is recommended.

Technical Data

Model No.	Body Material	Pipe (Inch)	Orifice (mm)	Min. Operating Pressure Kg/cm ²	Max. Operating Pressure Kg/cm ²	Seal & Diaphragm Material	Flow Factor Kv m ³ / hr
PBN706BNMVO	BRASS	3/8"	16	0.5	10	NBR / EPDM / VITON	1.5
PBN206BNMVO	BRASS	1/2"	16	0.5	10	NBR / EPDM / VITON	2.1
PBN306BNMVO	BRASS	3/4"	20	0.5	10	NBR / EPDM / VITON	5.5
PBN406BNMVO	BRASS	1"	25	0.5	10	NBR / EPDM / VITON	9
PBN606BNMVO	BRASS	1 1/2"	36	0.5	10	NBR / EPDM / VITON	17.1
PBN806BNEWVO	BRASS	2"	50	0.5	10	NBR / EPDM / VITON	29.9

Dimension - NC (All dimensions in mm)

All Dimensions are approx.

Model No.	Port Size	Diagram No.	A	B	C	D	E	F
PBN706BNMVO	3/8"	17.1	62	97	85	43	28	33
PBN206BNMVO	1/2"	17.1	62	97	85	43	28	33
PBN306BNMVO	3/4"	17.1	77	101	85	52	28	33
PBN406BNMVO	1"	17.1	92	109	89	63	28	33
PBN606BNMVO	1 1/2"	17.1	120	123	95	81	28	33
PBN806BNEWVO	2"	17.1	145	153	120	106	38	48

Section View

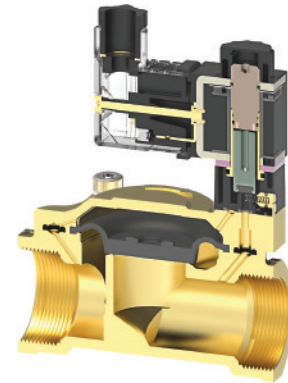

PILOT OPERATED DIAPHRAGM TYPE SOLENOID VALVE MODEL IDENTIFICATION CHART

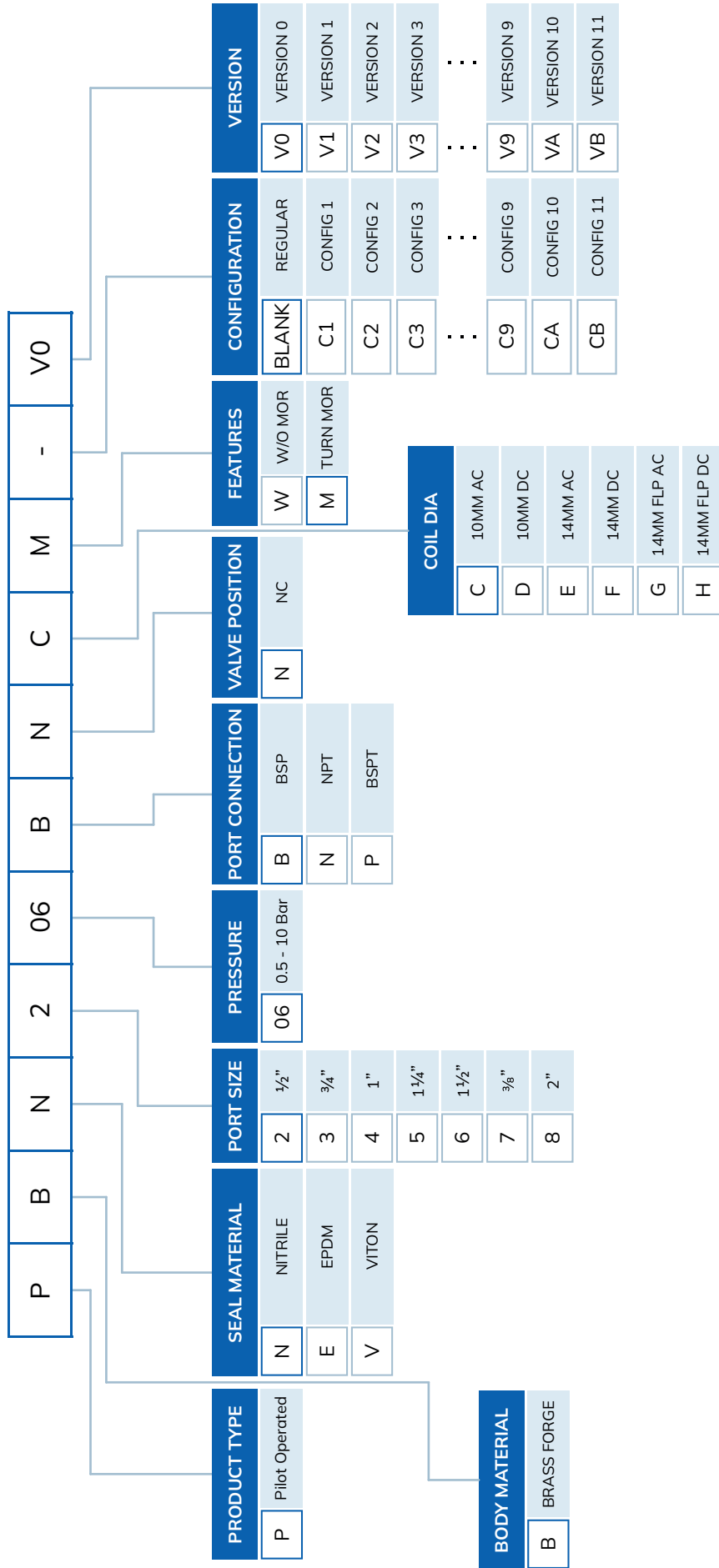

PBN206BNCMV0

1/2" PILOT OPERATED DIAPHRAGM BRASS FORGE-NITRILE-0.5 TO 10 Bar-BSP-NC-10MM AC-TURN MOR

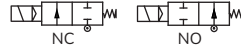
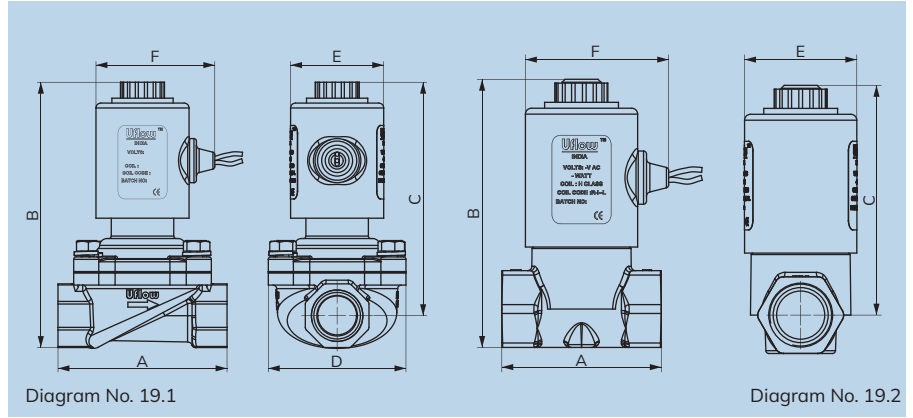

Specifications

Port :	3/8", 1/2", 3/4", 1", 1 1/2" & 2" (Available BSP / NPT)				
End Connection :	Screwed / Flange				
Body Material :	SS ASTM A351 Grade CF8 / CF8M, Forged Brass				
Diaphragm :	Nitrile (NBR)	EPDM	Viton (FKM)	PTFE	
Media Temp :	-30°C to 90°C	-10°C to 140°C	-10°C to 180°C	-10°C to 180°C	
Circumstance Temp :	-10°C to 70°C				
Media :	Air, Water, Chemical, Gas, Oil, Steam, LPG.				
Main Features :	Internal Parts are in superior corrosion resistance steel, (Equivalent to SS316L) Suitable for Food Industries, Pharmaceuticals, Chemical application & Highly corrosive environment.				
Operating Voltage :	24AC	110AC	230AC	12DC	24DC
Power Consumption :	9W	9W	9W	10W	11W
Coil Features :	High Reliability Unaffected by Voltage Surges. Easy coil changes coil lockable in 4X90 position or freely movable in between as require.				
Coil Housing :	IP65 Epoxy square coil, IP65 Metallic round enclosure, IP67 Flameproof enclosure, IP68 Weatherproof enclosure.				
Optional Feature :	90% Power saver series also available, Water hammering reducer also available to avoid water hammer forces. Special high flow rate series available on request at low pressure or gravity pressure application.				

Note : Use of filter in the inlet port is recommended., Preferably Over Horizontal Pipeline with the coil upright.
Caution : AC coil should not be used on a DC coil valve.

Technical Data

Model No.	Body Material	Pipe (Inch)	Orifice (mm)	Min. Operating Pressure Kg/cm ²	Max. Operating Pressure Kg/cm ²	Seal & Diaphragm Material	Flow Factor Kv m ³ / hr
MBN703BNEV0	BRASS	3/8"	15.5	0	7	NBR / EPDM / VITON	2.5
MBN704BNEV0	BRASS	3/8"	12	0	10	NBR / EPDM / VITON	2.5
MBN203BNEV0	BRASS	1/2"	15.5	0	7	NBR / EPDM / VITON	3.1
MBN204BNEV0	BRASS	1/2"	12	0	10	NBR / EPDM / VITON	2.3
MCN204BNEV0	CF8 / CF8M	1/2"	15	0	10	NBR / EPDM / VITON	2.5
MCN203BNEV0	CF8 / CF8M	1/2"	17	0	7	NBR / EPDM / VITON	3.2
MCN303BNEV0	CF8 / CF8M	3/4"	20	0	7	NBR / EPDM / VITON	5
MCN304BNEV0	CF8 / CF8M	3/4"	18	0	10	NBR / EPDM / VITON	2.1
MCN403BNEV0	CF8 / CF8M	1"	25.5	0	7	NBR / EPDM / VITON	8.2
MCN613BNIV0	CF8 / CF8M	1 1/2"	38	0	4	NBR / EPDM / VITON	18.2
MCN813BNIV0	CF8 / CF8M	2"	46.5	0	4	NBR / EPDM / VITON	31.4

Dimension - NC (All dimensions in mm)

All Dimensions are approx.

Model No.	Port Size	Diagram No.	A	B	C	D	E	F
MBN703BNEV0	3/8"	19.1	57	107	93	46	38	49
MBN203BNEV0	1/2"	19.1	57	107	93	46	38	49
MBN204BNEV0	1/2"	19.2	54	94	80	-	38	49
MCN203BNEV0	1/2"	19.1	69	109	95	56	38	49
MCN303BNEV0	3/4"	19.1	76	114	98	62	38	49
MCN304BNEV0	3/4"	19.2	65	101	85	-	38	49
MCN403BNEV0	1"	19.1	100	122	102	78	38	49
MCN613BNIV0	1 1/2"	19.1	108	151	124	89	50	62
MCN813BNIV0	2"	19.1	130	170	137	107	50	62

In normally open valve dimension B&C will increase up to 8mm.

Section View

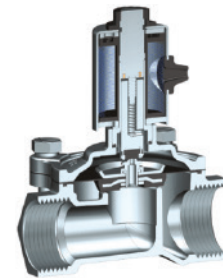

SEMI LIFT DIAPHRAGM OPERATED SOLENOID VALVE MODEL IDENTIFICATION CHART

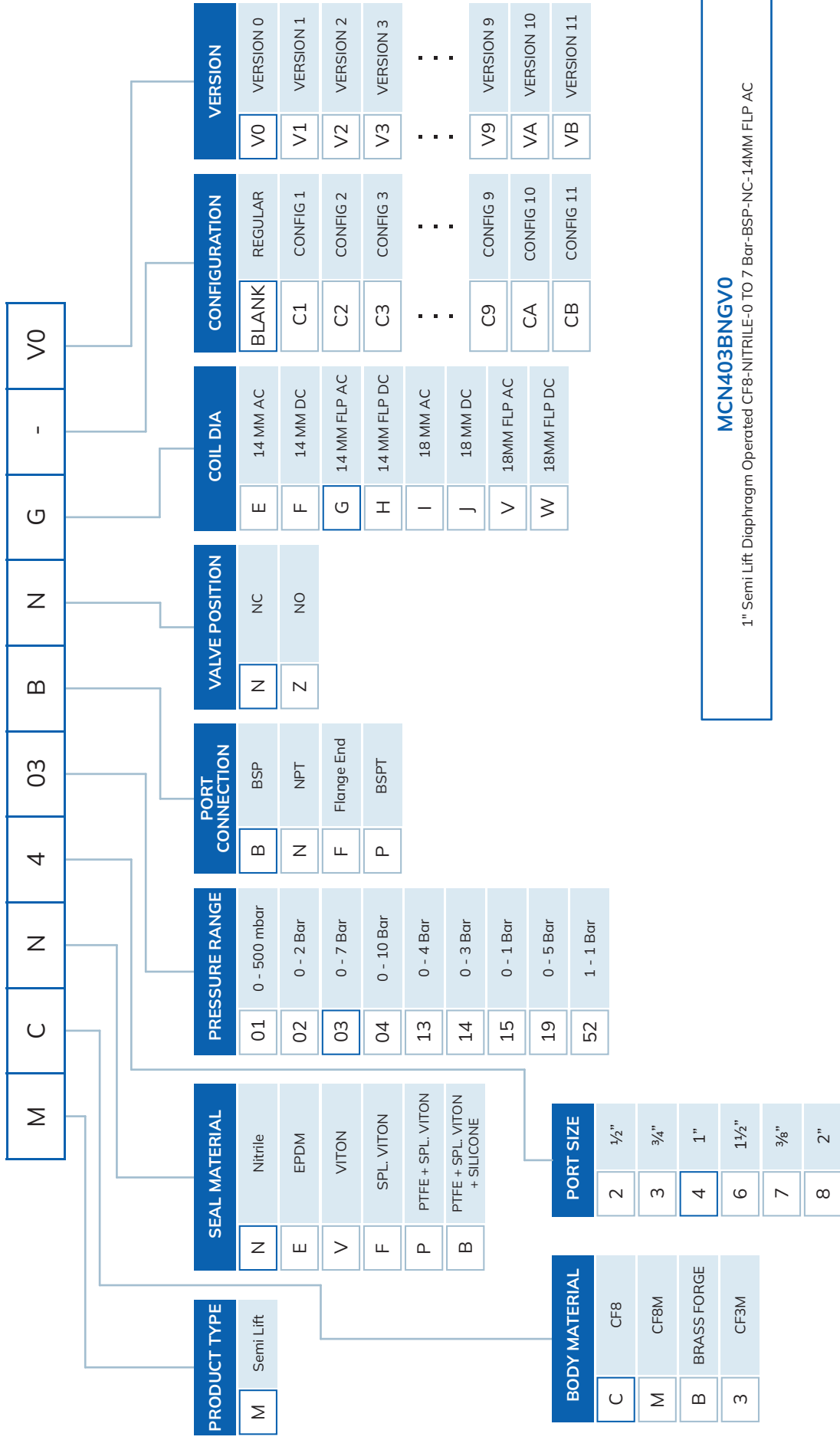

MCN403BNGV0

1" Semi Lift Diaphragm Operated CF8-NITRILE-0 TO 7 Bar-BSP-NC-14MM FLP AC

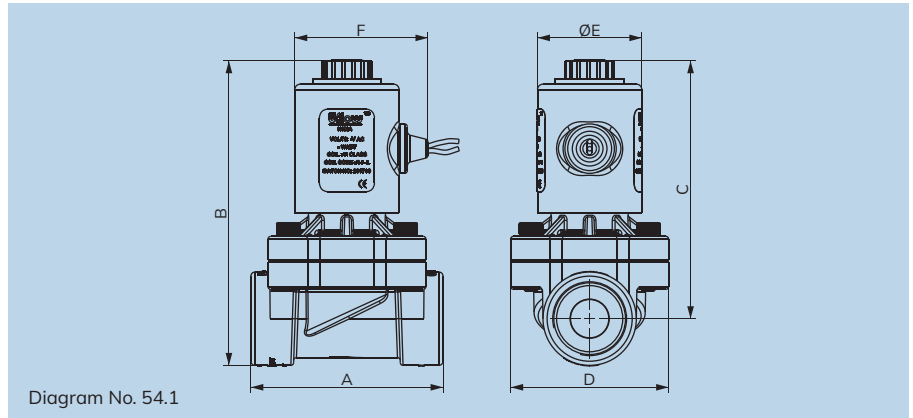

Specifications

Port :	½", ¾" & 1" (Available in BSP / BSPT / NPT)			
End Connection :	Screwed			
Body Material :	Nylon Glass Filled			
Diaphragm :	Nitrile (NBR)			
Media Temp. :	5°C to 50°C			
Circumstance Temp. :	-10°C to 50°C			
Media :	Water, Air, Inert Gas			
Main Features :	Internal Parts are in superior corrosion resistance steel, (Equivalent to SS316L) Suitable for Food Industries, Pharmaceuticals, Chemical application & Highly corrosive environment.			
Operating Voltage :	110AC	230AC	12DC	24DC
Power Consumption :	11W	10W	10W	11W
Coil Features :	High Reliability Unaffected by Voltage Surges. Easy coil changes coil lockable in 4X90 position or freely movable in between as require.			
Coil Housing :	IP65 Epoxy square coil, IP65 Metallic round enclosure, IP68 Weatherproof enclosure.			
Other Specification Data :	Available on Request			

NOTE: Use of filter in the inlet port is recommended.

Technical Data

Model No.	Body Material	Pipe (Inch)	Orifice (mm)	Min. Operating Pressure mbar	Max. Operating Pressure bar	Seal & Diaphragm Material	Flow Factor Kv m ³ / hr
MNN203BNEV0	Nylon GF	½"	16	0	7	NBR	2.1
MNN303BNEV0	Nylon GF	¾"	16	0	7	NBR	3
MNN413BNEV0	Nylon GF	1"	26	0	4	NBR	8.2

Dimension (All dimensions are in mm)

All Dimensions are approx.

Model No.	Port Size	Diagram No.	A	B	C	D	E	E1
MNN203BNEV0	½"	54.1	70	110	94	58	44	57
MNN303BNEV0	¾"	54.1	70	110	94	58	44	57
MNN413BNEV0	1"	54.1	107	122	101	77	44	57

Section View

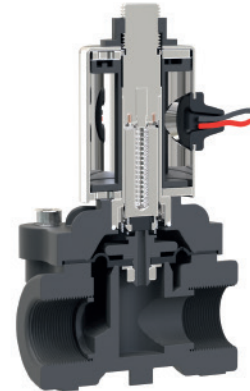

SEMI LIFT DIAPHRAGM OPERATED PLASTIC SOLENOID VALVE MODEL IDENTIFICATION CHART

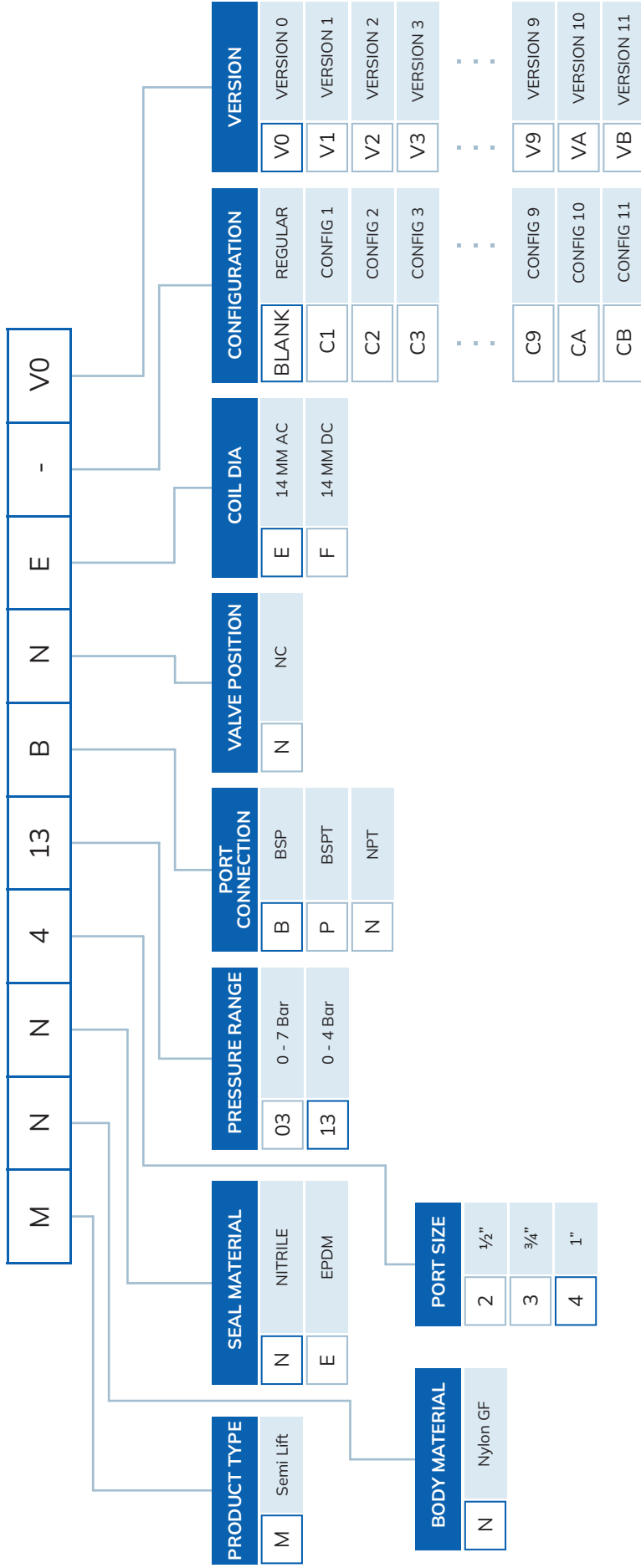

MNN413BNEVO

1" SEMI LIFT DIAPHRAGM OPERATED NYLON GF-NITRILE-0 TO 4 Bar-BSP-NC-14MM AC

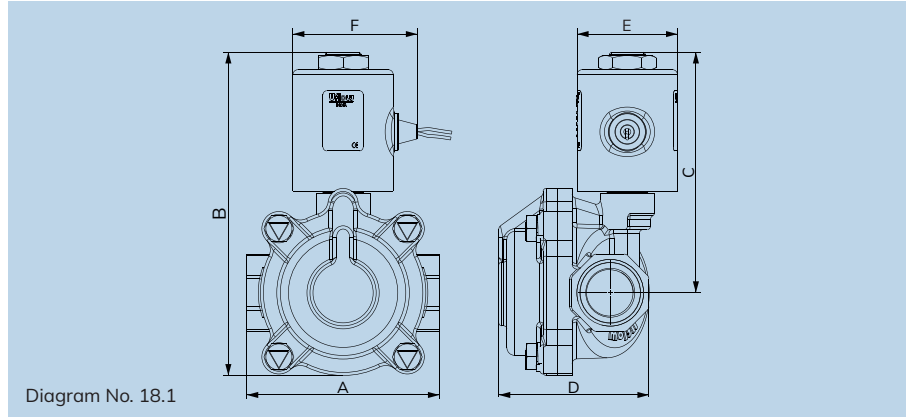
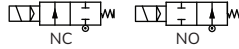

Diagram No. 18.1



Specifications

Port :	½", ¾", 1", 1¼", 1½" & 2" (Available BSP / NPT)				
End Connection :	Screwed / Flange				
Body Material :	SS ASTM A351 Grade CF8 / CF8M				
Diaphragm :	PTFE + SPL. Viton		PTFE + NBR		
Media Temp :	-10°C to 180°C		-10°C to +90°C		
Circumstance Temp :	-10°C to 70°C				
Media :	Steam, Hot Water, Hot Fluid, Oil				
Main Features :	Internal Parts are in superior corrosion resistance steel, (Equivalent to SS316L) Suitable for Food Industries, Pharmaceuticals, Chemical application & Highly corrosive environment.				
Operating Voltage :	24AC	110AC	230AC	12DC	24DC
Power Consumption :	15W	15W	15W	15W	15W
Coil Features :	High Reliability Unaffected by Voltage Surges. Easy coil changes coil lockable in 4X90 position or freely movable in between as require.				
Coil Housing :	IP65 Epoxy square coil, IP65 Metallic round enclosure, IP67 Flameproof enclosure, IP68 Weatherproof enclosure.				
Optional Feature :	90% Power saver series also available, Water hammering reducer also available to avoid water hammer forces.				
Other Specification Data :	Available on Request.-Manual Override				

Dimension - NC (All dimensions in mm)

All Dimensions are approx.

Model No.	Port Size	Diagram No.	A	B	C	D	E	F
HCP209BNIWV0	½"	18.1	67	138	110.5	60	50	63
HCP309BNIWV0	¾"	18.1	81	145.2	112.5	71	50	63
HCP409BNIWV0	1"	18.1	96	161	120	75	50	63
HCP509BNIWV0	1¼"	18.1	108	169.5	123.5	96	50	63
HCP609BNIWV0	1½"	18.1	108	169.5	123.5	96	50	63
HCP809BNIWV0	2"	18.1	132	196	140.8	114	50	63

In normally open valve dimension B&C will increase up to 8mm.

Section View

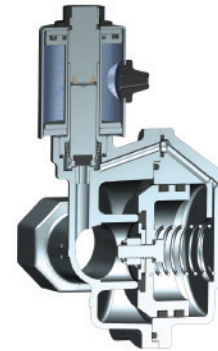

Technical Data

Model No.	Body Material	Pipe (Inch)	Orifice (mm)	Min. Operating Pressure Kg/cm ²	Max. Operating Pressure Kg/cm ²	Seal & Diaphragm Material	Flow Factor Kv m ³ / hr
HCP209BNIWV0	CF8 / CF8M	½"	17	1.5	12	PTFE	4
HCP309BNIWV0	CF8 / CF8M	¾"	20	1.5	12	PTFE	7
HCP409BNIWV0	CF8 / CF8M	1"	25	1.5	12	PTFE	12
HCP509BNIWV0	CF8 / CF8M	1¼"	36	1.5	12	PTFE	23
HCP609BNIWV0	CF8 / CF8M	1½"	36	1.5	12	PTFE	23
HCP809BNIWV0	CF8 / CF8M	2"	47	1.5	12	PTFE	38
HCA254BNIWV0	CF8 / CF8M	½"	17	4	45	PTFE + NBR	4
HCA354BNIWV0	CF8 / CF8M	¾"	20	4	45	PTFE + NBR	7
HCA454BNIWV0	CF8 / CF8M	1"	25	4	45	PTFE + NBR	12
HCA554BNIWV0	CF8 / CF8M	1¼"	36	4	45	PTFE + NBR	23
HCA654BNIWV0	CF8 / CF8M	1½"	36	4	45	PTFE + NBR	23
HCA854BNIWV0	CF8 / CF8M	2"	47	4	45	PTFE + NBR	38

PILOT OPERATED PISTON TYPE SOLENOID VALVE MODEL IDENTIFICATION CHART

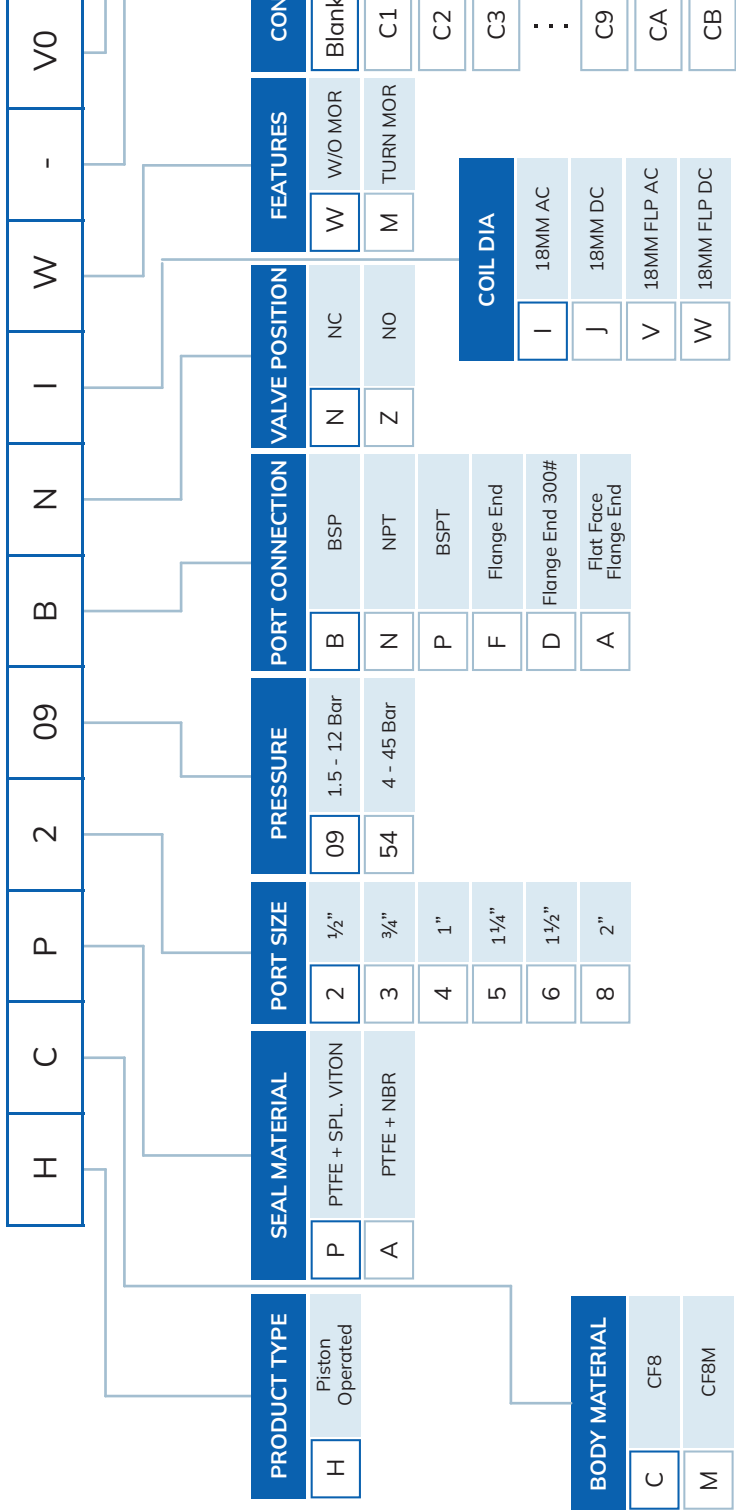

HCP209BNIWVO
 1/2" PILOT OPERATED DIAPHRAGM- CF8- PTFE + SPL. VITON- 1.5 TO 12 Bar-BSP-NC-18MM AC- W/OMOR

Note: The above chart is for identification purposes only, and it may not be possible to make all combinations for the above chart.

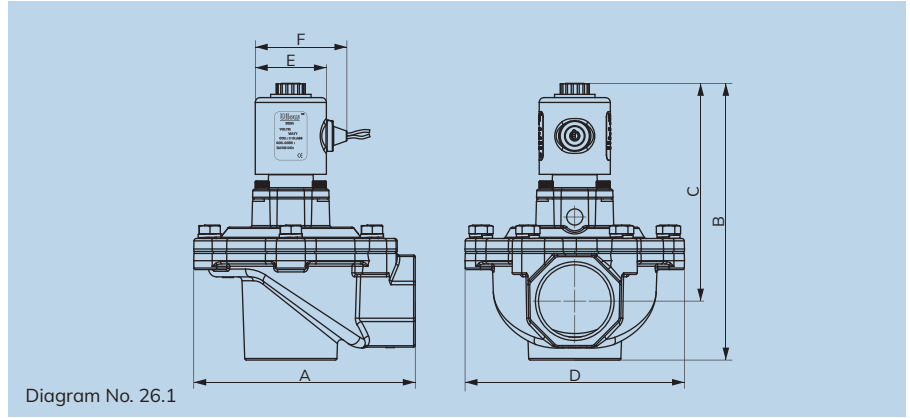

Specifications

Port :	¾", 1", 1½", 2" & 2½" (Available in BSP /NPT)				
End Connection :	Screwed				
Body Material :	Aluminum Die Cast				
Diaphragm:	Nitrile (NBR)				
Media Temp:	-30°C to 90°C				
Circumstance Temp :	-10°C to 70°C				
Media :	Air				
Main Features :	Internal Parts are in superior corrosion resistance steel, (Equivalent to SS316L) Suitable for Air Pollution Control System, Bag Filter Machine				
Operating Voltage :	24AC	110AC	230AC	12DC	24DC
Power Consumption :	9W	9W	9W	10W	11W
Coil Features :	High Reliability Unaffected by Voltage Surges. Easy coil changes coil lockable in 4X90 position or freely movable in between as require.				
Coil Housing :	IP65 Epoxy square coil, IP65 Metallic round enclosure, IP67 Flameproof enclosure, IP68 Weatherproof enclosure.				
Optional Feature :	90% Power saver series also available.				
Other Specification Data :	Available on Request - Brass silencer to reduce extra noise				

NOTE: Use of filter in the inlet port is recommended.

Technical Data

Model No.	Body Material	Pipe (Inch)	Orifice (mm)	Min. Operating Pressure Kg/cm ²	Max. Operating Pressure Kg/cm ²	Seal & Diaphragm Material	Flow Factor Kv m ³ / hr
JAN307BERV0	Aluminium	¾"	28.50	0.5	8.5	NBR	11
JAN407BERV0	Aluminium	1"	28.50	0.5	8.5	NBR	16
JAN607BERV0	Aluminium	1½"	51	0.5	8.5	NBR	40
JAN807BERV0	Aluminium	2"	52	0.5	8.5	NBR	78
JAN907BERV0	Aluminium	2½"	65	0.5	8.5	NBR	120
JAN607BESV0	Aluminium	1½"	51	0.5	8.5	NBR	40
JAN807BESV0	Aluminium	2"	52	0.5	8.5	NBR	78
JAN907BESV0	Aluminium	2½"	65	0.5	8.5	NBR	120

Dimension (All dimensions are in mm)

All Dimensions are approx.

Model No.	Port Size	Diagram No.	A	B	C	D	E	F
JAN307BERV0	¾"	26.1	89	134	110	75	38	49
JAN407BERV0	1"	26.1	89	134	110	75	38	49
JAN607BERV0	1½"	26.1	137	171	135	136	38	49
JAN807BERV0	2"	26.1	171	206	161	169	38	49
JAN907BERV0	2½"	26.1	171	206	161	169	38	49

Section View

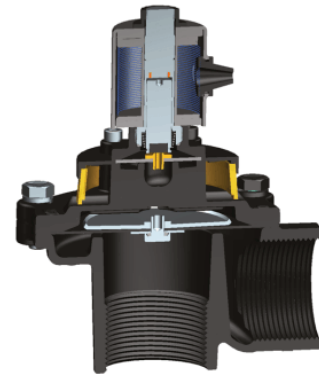

PULSE JET ANGLE TYPE DUST COLLECTOR TYPE SOLENOID VALVE MODEL IDENTIFICATION CHART

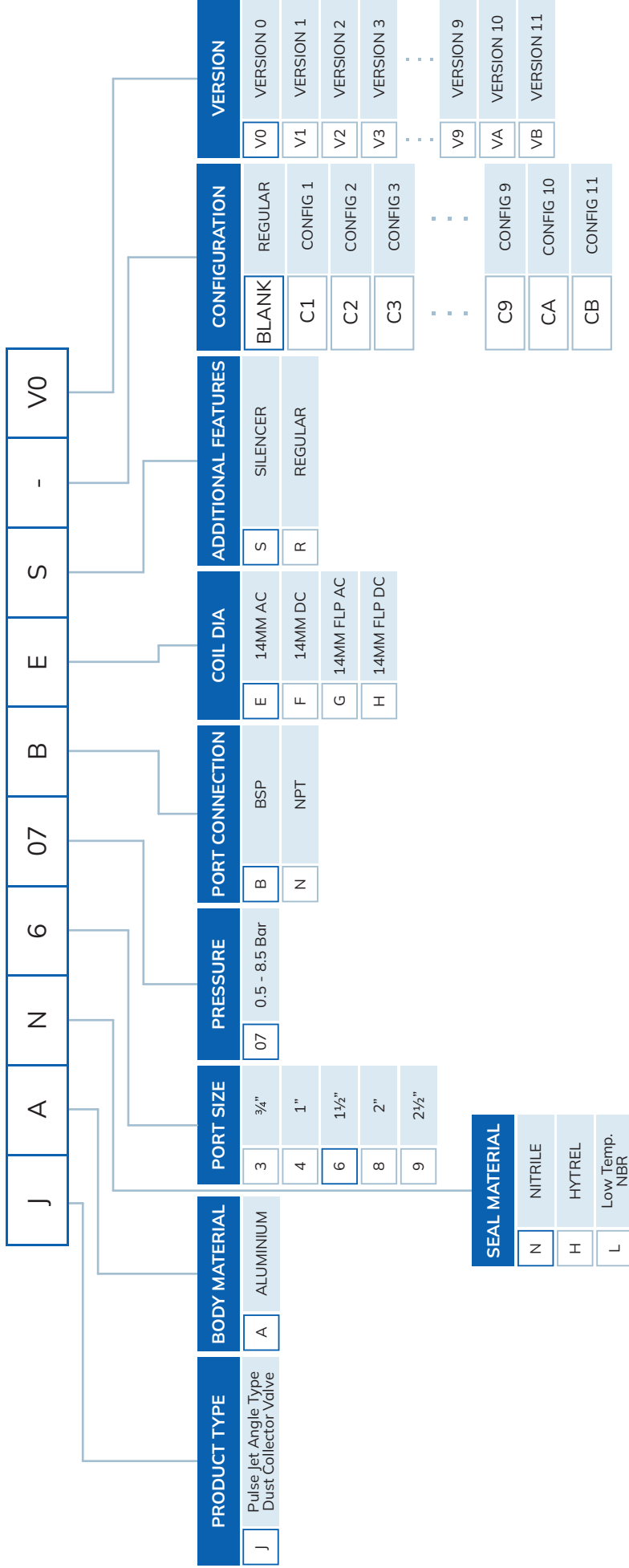

JAN607BESV0
 1 1/2" PULSE JET ANGLE TYPE DUST COLLECTOR ALUMINIUM-NITRILE-0.5 TO 8.5 Bar-BSP-14MM-SILENCER

Note: The above chart is for identification purposes only, and it may not be possible to make all combinations for the above chart.

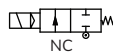
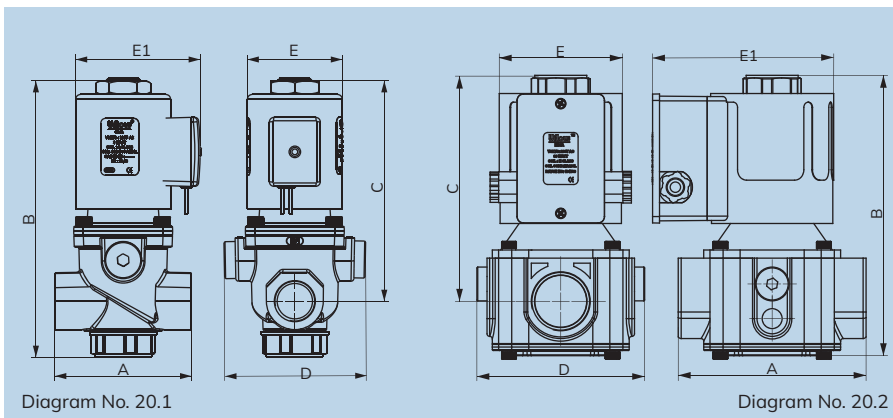

Specifications

Port :	½" & 1" (Available in BSP)	
End Connection :	Screwed	
Body Material :	Aluminum Pressure Die Cast	
Diaphragm :	Nitrile (NBR)	
Media Temp :	-30°C to 90°C	
Circumstance Temp :	-10°C to 70°C	
Media :	Air, Natural Gas, Town Gas	
Main Features :	Flow adjustment, Opening time adjustment, Quick release initial flow adjustment	
Operating Voltage :	110AC	230AC
Power Consumption :	30W	30W
Coil Features :	High Reliability Unaffected by Voltage Surges. Easy coil changes coil lockable in 4X90 position or freely movable in between as require.	
Coil Housing :	IP65 Epoxy square coil & Power Saver Coil	

NOTE: Use of filter in the inlet port is recommended.

- Coils are conforming as per IEC-60335-1 with derivatives (LVD / EMC).
- Gas Solenoid Valve complies as per EN-161 requirement.

Dimension (All dimensions are in mm)

All Dimensions are approx.

Model No.	Port Size	Diagram No.	A	B	C	D	E	E1
DAN201BNIW152V0	½"	20.1	72	147	117	75	50	66
DAN400BNKW300V0	1"	20.2	108	164	132	97	71	105

Section View

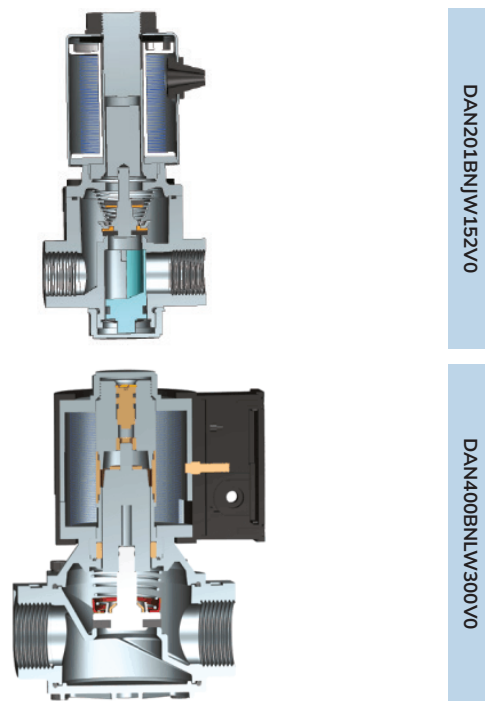

Technical Data

Model No.	Body Material	Pipe (Inch)	Orifice (mm)	Min. Operating Pressure mbar	Max. Operating Pressure mbar	Seal & Diaphragm Material	Flow Factor Kv m³ / hr
DAN201BNIW152V0	Aluminium	½"	15	0	500	NBR	4
DAN400BNKW300V0	Aluminium	1"	30	0	350	NBR	13

NOTE: Please refer the direct acting model identification chart.

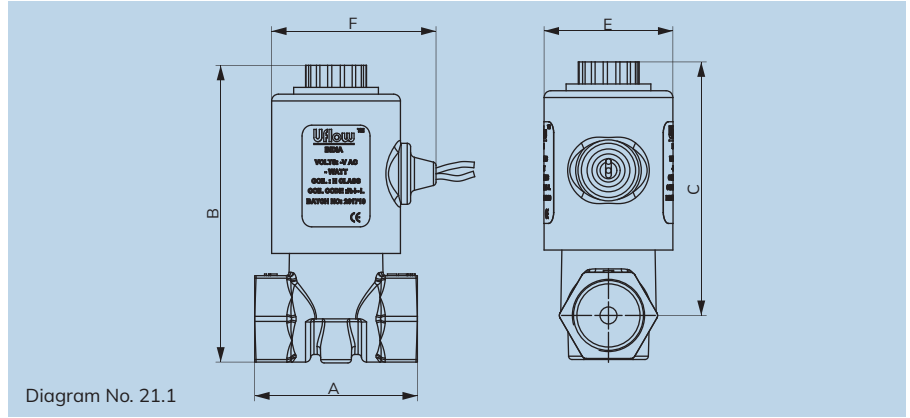
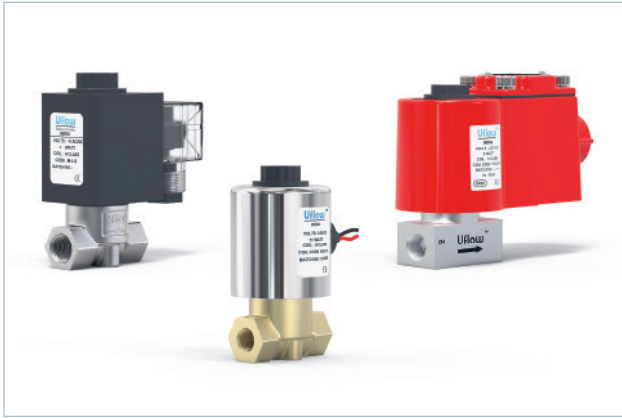

Specifications

Port :	1/8", 1/4", 3/8" & 1/2" (Available BSP / NPT)				
End Connection :	Screwed				
Body Material :	SS ASTM A351 Grade CF8 / CF8M, Forged Brass, Aluminium				
Diaphragm:	Nitrile (NBR)	EPDM	Viton (FKM)	Silicone	
Media Temp:	-30°C to 90°C	-10°C to 140°C	-10°C to 180°C	-10°C to 60°C	
Circumstance Temp :	-10°C to 70°C				
Media :	Air, Chemical, Gas, Oil, Steam, Hot Water				
Main Features :	Internal Parts are in superior corrosion resistance steel, (Equivalent to SS316L) Suitable for Food Industries, Pharmaceuticals, Chemical application & Highly corrosive environment.				
Operating Voltage :	24AC	110AC	230AC	12DC	24DC
Power Consumption :	9W	9W	9W	10W	11W
Coil Features :	High Reliability Unaffected by Voltage Surges. Easy coil changes coil lockable in 4X90 position or freely movable in between as require.				
Coil Housing :	IP65 Epoxy square coil, IP65 Metallic round enclosure, IP67 Flameproof enclosure, IP68 Weatherproof enclosure.				
Optional Feature :	90% Power saver series also available & Latching as per Application.				
Other Specification Data :	Available on Request. - Manual Override				

NOTE: Use of filter in the inlet port is recommended.

Dimension - NC (All dimensions in mm)

All Dimensions are approx.

Model No.	Port Size	Diagram No.	A	B	C	E	F
DAN104BNEW030V0	1/4"	21.1	44.5	81	71	38	49
DBN104BNEW040V0	1/4"	21.1	43	83	74	38	49
DCN104BNEW040V0	1/4"	21.1	43	83	74	38	49
DBN704BNEW040V0	3/8"	21.1	48	88	75	38	49
DBN204BNEW040V0	1/2"	21.1	48	88	75	38	49
DCN202BNIW120V0	1/2"	21.1	55	109	96	50	62
DAN204BNIW050V0	1/2"	21.1	53	102	88	50	62
DBN004BNCW020V0	1/8"	21.1	38	58	49	28	33
DCN204BNEW040V0	1/2"	21.1	48	88	75	38	49

In normally open valve dimension B&C will increase up to 8mm.

Section View

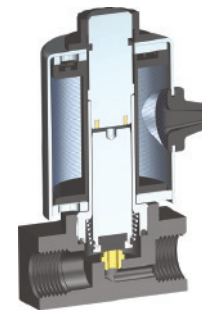

Technical Data

Model No.	Body Material	Port Size	Orifice (mm)		Min. Operating Pressure Kg/cm ²	Max. Operating Pressure Kg/cm ²	Seal & Diaphragm Material	Flow Factor Kv m ³ / hr	
			NC	NO				NC	NO
DAN113BNFW050V0	Aluminium	1/4"	5	4	0	4	NBR / FKM / EPDM	0.73	0.54
DAN104BNEW030V0	Aluminium	1/4"	3	2.5	0	10	NBR / FKM / EPDM	0.20	0.16
DAN105BNEW022V0	Aluminium	1/4"	2.2	1.8	0	16	NBR / FKM / EPDM	0.16	0.10
DAN111BNEW022V0	Aluminium	1/4"	2.2	1.8	0	25	NBR / FKM / EPDM	0.16	0.10
DAN118BNEW018V0	Aluminium	1/4"	1.8	1.3	0	40	NBR / FKM / EPDM	0.10	0.05
DAN117BNEW015V0	Aluminium	1/4"	1.5	1.3	0	60	NBR / FKM / EPDM	0.07	0.05
DAN204BNIW050V0	Aluminium	1/2"	5	NA	0	10	NBR / FKM / EPDM	0.73	-

Technical Data

Model No.	Body Material	Port Size	Orifice (mm)		Min. Operating Pressure Kg/cm ²	Max. Operating Pressure Kg/cm ²	Seal & Diaphragm Material	Flow Factor Kv m ³ / hr	
			NC	NO				NC	NO
DAN204BNEW040V0	Aluminium	½"	4	2.5	0	10	NBR / FKM / EPDM	0.54	0.16
DAN205BNEW030V0	Aluminium	½"	3	2	0	16	NBR / FKM / EPDM	0.20	0.11
DAN204BNIW050V0	Aluminium	½"	5	4	0	10	NBR / FKM / EPDM	0.73	0.54
DAN217BNIW025V0	Aluminium	½"	2.5	NA	0	60	NBR / FKM / EPDM	0.16	-
DBN017BNEW018V0	Brass	⅜"	1.8	NA	0	60	NBR / FKM / EPDM	0.10	-
DBN115BNEW060V0	Brass	¼"	6	NA	0	1	NBR / FKM / EPDM	0.84	-
DBN113BNEW050V0	Brass	¼"	5	4	0	4	NBR / FKM / EPDM	0.73	0.54
DBN104BNEW040V0	Brass	¼"	4	2.5	0	10	NBR / FKM / EPDM	0.54	0.16
DBN105BNEW030V0	Brass	¼"	3	2.5	0	16	NBR / FKM / EPDM	0.20	0.16
DBN111BNEW025V0	Brass	¼"	2.5	1.8	0	25	NBR / FKM / EPDM	0.16	0.10
DBN118BNEW020V0	Brass	¼"	2	1.3	0	40	NBR / FKM / EPDM	0.11	0.05
DBN117BNEW018V0	Brass	¼"	1.8	1.3	0	60	NBR / FKM / EPDM	0.10	0.05
DBN120BNEW015V0	Brass	¼"	1.5	0.9	0	100	NBR / FKM / EPDM	0.07	0.03
DBN112BNEW013V0	Brass	¼"	1.3	NA	0	150	NBR / FKM / EPDM	0.05	--
DBN713BNEW050V0	Brass	⅜"	5	4	0	4	NBR / FKM / EPDM	0.73	0.54
DBN704BNEW040V0	Brass	⅜"	4	2.5	0	10	NBR / FKM / EPDM	0.54	0.16
DBN705BNEW030V0	Brass	⅜"	3	2	0	16	NBR / FKM / EPDM	0.20	0.11
DBN711BNEW025V0	Brass	⅜"	2.5	1.8	0	25	NBR / FKM / EPDM	0.16	0.10
DBN718BNEW020V0	Brass	⅜"	2	1.5	0	40	NBR / FKM / EPDM	0.11	0.03
DBN717BNEW018V0	Brass	⅜"	1.8	1.3	0	60	NBR / FKM / EPDM	0.10	0.05
DBN720BNEW015V0	Brass	⅜"	1.5	0.9	0	100	NBR / FKM / EPDM	0.07	0.03
DBN712BNEW013V0	Brass	⅜"	1.3	NA	0	150	NBR / FKM / EPDM	0.05	--
DBN215BNEW060V0	Brass	½"	6	NA	0	1	NBR / FKM / EPDM	0.84	--
DBN213BNEW050V0	Brass	½"	5	4	0	4	NBR / FKM / EPDM	0.73	0.54
DBN204BNEW040V0	Brass	½"	4	2.5	0	10	NBR / FKM / EPDM	0.54	0.16
DBN205BNEW030V0	Brass	½"	3	2.5	0	16	NBR / FKM / EPDM	0.20	0.16
DBN211BNEW025V0	Brass	½"	2.5	1.8	0	25	NBR / FKM / EPDM	0.16	0.10
DBN218BNEW020V0	Brass	½"	2	1.3	0	40	NBR / FKM / EPDM	0.11	0.05
DBN217BNEW018V0	Brass	½"	1.8	1.3	0	60	NBR / FKM / EPDM	0.10	0.05
DBN220BNEW015V0	Brass	½"	1.5	0.9	0	100	NBR / FKM / EPDM	0.07	0.03
DBN212BNEW013V0	Brass	½"	1.3	NA	0	150	NBR / FKM / EPDM	0.05	--
DCN017BNEW018V0	SS304	⅜"	1.8	NA	0	60	NBR / FKM / EPDM	0.16	--
DCN115BNEW060V0	SS304	¼"	6	6	0	1	NBR / FKM / EPDM	0.84	0.84
DCN113BNEW050V0	SS304	¼"	5	4	0	4	NBR / FKM / EPDM	0.73	0.54
DCN104BNEW040V0	SS304	¼"	4	2.5	0	10	NBR / FKM / EPDM	0.54	0.16
DCN105BNEW030V0	SS304	¼"	3	2	0	16	NBR / FKM / EPDM	0.20	0.11
DCN111BNEW025V0	SS304	¼"	2.5	1.8	0	25	NBR / FKM / EPDM	0.16	0.10
DCN118BNEW020V0	SS304	¼"	2	1.3	0	40	NBR / FKM / EPDM	0.11	0.05
DCN117BNEW018V0	SS304	¼"	1.8	1.3	0	60	NBR / FKM / EPDM	0.10	0.05
DCN120BNEW015V0	SS304	¼"	1.5	0.9	0	100	NBR / FKM / EPDM	0.07	0.03
DCN112BNEW013V0	SS304	¼"	1.3	NA	0	150	NBR / FKM / EPDM	0.05	--
DCN713BNEW050V0	SS304	⅜"	5	4	0	4	NBR / FKM / EPDM	0.73	0.54
DCN704BNEW040V0	SS304	⅜"	4	2.5	0	10	NBR / FKM / EPDM	0.54	0.16
DCN705BNEW030V0	SS304	⅜"	3	2	0	16	NBR / FKM / EPDM	0.20	0.11
DCN711BNEW025V0	SS304	⅜"	2.5	1.8	0	25	NBR / FKM / EPDM	0.16	0.10

Technical Data

Model No.	Body Material	Port Size	Orifice (mm)		Min. Operating Pressure Kg/cm ²	Max. Operating Pressure Kg/cm ²	Seal & Diaphragm Material	Flow Factor Kv m ³ / hr	
			NC	NO				NC	NO
DCN718BNEW020V0	SS304	3/8"	2	1.3	0	40	NBR / FKM / EPDM	0.11	0.05
DCN717BNEW018V0	SS304	3/8"	1.8	1.3	0	60	NBR / FKM / EPDM	0.10	0.05
DCN720BNEW015V0	SS304	3/8"	1.5	0.9	0	100	NBR / FKM / EPDM	0.07	0.03
DCN712BNEW013V0	SS304	3/8"	1.3	NA	0	150	NBR / FKM / EPDM	0.05	--
DCS226BNEW170V0	SS304	1/2"	17	NA	0	0.200	NBR / SI / FKM / EPDM	3.20	--
DCN213BNEW050V0	SS304	1/2"	5	4	0	4	NBR / FKM / EPDM	0.73	0.54
DCN204BNEW040V0	SS304	1/2"	4	2.5	0	10	NBR / FKM / EPDM	0.54	0.16
DCN205BNEW030V0	SS304	1/2"	3	2.5	0	16	NBR / FKM / EPDM	0.20	0.16
DCN211BNEW025V0	SS304	1/2"	2.5	1.8	0	25	NBR / FKM / EPDM	0.16	0.10
DCN218BNEW020V0	SS304	1/2"	2	1.3	0	40	NBR / FKM / EPDM	0.11	0.05
DCN217BNEW018V0	SS304	1/2"	1.8	1.3	0	60	NBR / FKM / EPDM	0.10	0.05
DCN220BNEW015V0	SS304	1/2"	1.5	0.9	0	100	NBR / FKM / EPDM	0.07	0.03
DCN212BNEW013V0	SS304	1/2"	1.3	NA	0	150	NBR / FKM / EPDM	0.05	--
DCS202BNIW120V0	SS304	1/2"	12	NA	0	2	NBR / SI / FKM / EPDM	2.10	--
DCN202BNIW120V0	SS304	1/2"	12	NA	0	2	NBR / FKM / EPDM	2.10	--
DCN201BNIW120V0	SS304	1/2"	12	12	0	0.500	NBR / FKM / EPDM	2.10	2.10
DAN004BNCW020V0	Aluminum	1/8"	2	NA	0	10	NBR / FKM / EPDM	0.11	--
DAN102BNCW025V0	Aluminum	1/4"	2.5	NA	0	2	NBR / FKM / EPDM	0.16	--
DAN104BNCW020V0	Aluminum	1/4"	2	NA	0	10	NBR / FKM / EPDM	0.11	--
DBN014BNCW030V0	Brass	1/8"	3	NA	0	3	NBR / FKM / EPDM	0.20	--
DBN004BNCW020V0	Brass	1/8"	2	NA	0	10	NBR / FKM / EPDM	0.11	--
DBN104BNCW020V0	Brass	1/4"	2	NA	0	10	NBR / FKM / EPDM	0.11	--
DCN004BNCW020V0	SS304	1/8"	2	NA	0	10	NBR / FKM / EPDM	0.11	--
DCN102BNCW020V0	SS304	1/4"	2	NA	0	2	NBR / FKM / EPDM	0.11	--
DCN103BNCW025V0	SS304	1/4"	2.5	NA	0	7	NBR / FKM / EPDM	0.16	--
DCN104BNCW020V0	SS304	1/4"	2	NA	0	10	NBR / FKM / EPDM	0.11	--

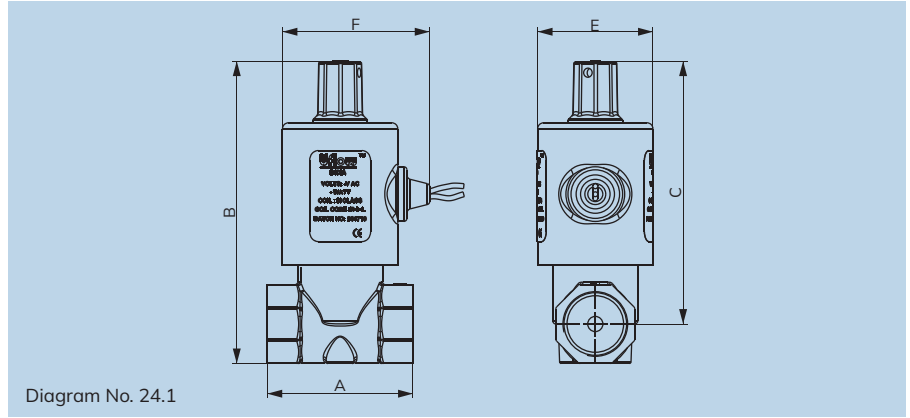

Diagram No. 24.1



Specifications

Port :	1/8", 1/4", 3/8" & 1/2" (Available BSP / NPT)			
End Connection :	Screwed			
Body Material :	SS ASTM A351 Grade CF8 / CF8M, Forged Brass, Aluminium			
Diaphragm:	Nitrile (NBR)	EPDM	Viton (FKM)	
Media Temp:	-30°C to 90°C	-10°C to 140°C	-10°C to 180°C	
Circumstance Temp :	-10°C to 70°C			
Media :	Air, Water, Chemical, Gas, Oil, Diesel, Kerosene, LPG.			
Main Features :	Internal Parts are in superior corrosion resistance steel, (Equivalent to SS316L) Suitable for Food Industries, Pharmaceuticals, Chemical application & Highly corrosive environment.			
Operating Voltage :	24AC	110AC	230AC	12DC 24DC
Power Consumption :	9W	9W	9W	10W 11W
Coil Features :	High Reliability Unaffected by Voltage Surges. Easy coil changes coil lockable in 4X90 position or freely movable in between as require.			
Coil Housing :	IP65 Epoxy square coil, IP65 Metallic round enclosure, IP67 Flameproof enclosure, IP68 Weatherproof enclosure.			
Optional Feature :	90% Power saver series also available.			
Other Specification Data :	Available on Request. - Manual Override			

NOTE: Use of filter in the inlet port is recommended.

Dimension - NC (All dimensions are in mm)

All Dimensions are approx.

Model No.	Port Size	Diagram No.	A	B	C	E	F
TAN104BNEW015V0	1/4"	24.1	45	93	83	38	49
TBN104BNEW015V0	1/4"	24.1	43	95	86	38	49
TCN104BNEW015V0	1/4"	24.1	43	95	85	38	49
TBN704BNEW015V0	3/8"	24.1	48	100	86	38	49
TBN204BNEW015V0	1/2"	24.1	48	100	87	38	49
TCN204BNEW015V0	1/2"	24.1	48	100	86	38	49
TBN004BNCW012V0	1/8"	24.1	38	58	49	28	33
TBN104BNCW012V0	1/4"	24.1	38	58	49	28	33

In normally open valve dimension B&C will increase up to 8mm.

Section View

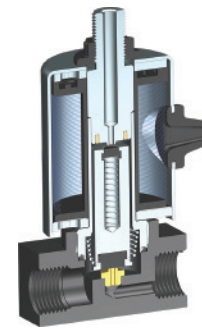

Technical Data

Model No.	Body Material	Port Size	Orifice (mm)		Min. Operating Pressure Kg/cm ²	Max. Operating Pressure Kg/cm ²	Seal & Diaphragm Material	Flow Factor Kv m ³ / hr	
			NC	NO				NC	NO
TAN119BNEW025V0	Aluminium	1/4"	2.5	-	0	5	NBR / FKM / EPDM	0.16	--
TAN104BNEW015V0	Aluminium	1/4"	1.5	1.5	0	10	NBR / FKM / EPDM	0.07	0.07
TAN105BNEW009V0	Aluminium	1/4"	0.9	0.9	0	16	NBR / FKM / EPDM	0.03	0.03
TAN111BNEW009V0	Aluminium	1/4"	0.9	0.9	0	25	NBR / FKM / EPDM	0.03	0.03
TAN118BNEW009V0	Aluminium	1/4"	0.9	0.9	0	40	NBR / FKM / EPDM	0.03	0.03
TAN104RNEW015V0	Aluminium	In : 1/4", Out : Namur	1.5	-	0	10	NBR / FKM / EPDM	0.07	--
TAN104RNET050V0	Aluminium	In : 1/4", Out : Namur	5	-	0	10	NBR / FKM / EPDM	0.73	--
TAN704BNEW015V0	Aluminium	3/8"	1.5	1.5	0	10	NBR / FKM / EPDM	0.07	0.07
TAN204BNEW015V0	Aluminium	1/2"	1.5	1.5	0	10	NBR / FKM / EPDM	0.07	0.07

Technical Data

Model No.	Body Material	Port Size	Orifice (mm)		Min. Operating Pressure Kg/cm ²	Max. Operating Pressure Kg/cm ²	Seal & Diaphragm Material	Flow Factor Kv m ³ / hr	
			NC	NO				NC	NO
TAN205BNEW009V0	Aluminium	½"	0.9	0.9	0	16	NBR / FKM / EPDM	0.03	0.03
TBN004BNEW015V0	Brass	⅛"	1.5	NA	0	10	NBR / FKM / EPDM	0.07	--
TBN119BNEW025V0	Brass	¼"	2.5	NA	0	5	NBR / FKM / EPDM	0.16	--
TBN104BNEW020V0	Brass	¼"	2	1.5	0	10	NBR / FKM / EPDM	0.11	0.07
TBN105BNEW009V0	Brass	¼"	0.9	0.9	0	16	NBR / FKM / EPDM	0.03	0.03
TBN111BNEW009V0	Brass	¼"	0.9	0.9	0	25	NBR / FKM / EPDM	0.03	0.03
TBN118BNEW009V0	Brass	¼"	0.9	0.9	0	40	NBR / FKM / EPDM	0.03	0.03
TBN719BNEW025V0	Brass	⅜"	2.5	NA	0	5	NBR / FKM / EPDM	0.16	--
TBN704BNEW015V0	Brass	⅜"	1.5	1.5	0	10	NBR / FKM / EPDM	0.07	0.07
TBN705BNEW009V0	Brass	⅜"	0.9	0.9	0	16	NBR / FKM / EPDM	0.03	0.03
TBN711BNEW009V0	Brass	⅜"	0.9	0.9	0	25	NBR / FKM / EPDM	0.03	0.03
TBN219BNEW025V0	Brass	½"	2.5	NA	0	5	NBR / FKM / EPDM	0.16	--
TBN204BNEW015V0	Brass	½"	1.5	1.5	0	10	NBR / FKM / EPDM	0.07	0.07
TBN211BNEW009V0	Brass	½"	0.9	0.9	0	25	NBR / FKM / EPDM	0.03	0.03
TBN205BNEW009V0	Brass	½"	0.9	0.9	0	16	NBR / FKM / EPDM	0.03	0.03
TBN218BNEW009V0	Brass	½"	0.9	0.9	0	40	NBR / FKM / EPDM	0.03	0.03
TCN119BNEW025V0	SS304	¼"	2.5	NA	0	5	NBR / FKM / EPDM	0.16	--
TCN104BNEW015V0	SS304	¼"	1.5	1.5	0	10	NBR / FKM / EPDM	0.07	0.07
TCN105BNEW009V0	SS304	¼"	0.9	0.9	0	16	NBR / FKM / EPDM	0.03	0.03
TCN118BNEW009V0	SS304	¼"	0.9	0.9	0	40	NBR / FKM / EPDM	0.03	0.03
TCN111BNEW009V0	SS304	¼"	0.9	0.9	0	25	NBR / FKM / EPDM	0.03	0.03
TCN719BNEW025V0	SS304	⅜"	2.5	NA	0	5	NBR / FKM / EPDM	0.16	--
TCN704BNEW015V0	SS304	⅜"	1.5	1.5	0	10	NBR / FKM / EPDM	0.07	0.07
TCN705BNEW009V0	SS304	⅜"	0.9	0.9	0	16	NBR / FKM / EPDM	0.03	0.03
TCN711BNEW009V0	SS304	⅜"	0.9	0.9	0	25	NBR / FKM / EPDM	0.03	0.03
TCN219BNEW025V0	SS304	½"	2.5	NA	0	5	NBR / FKM / EPDM	0.16	--
TCN204BNEW015V0	SS304	½"	1.5	1.5	0	10	NBR / FKM / EPDM	0.07	0.07
TCN205BNEW009V0	SS304	½"	0.9	0.9	0	16	NBR / FKM / EPDM	0.03	0.03
TCN211BNEW009V0	SS304	½"	0.9	0.9	0	25	NBR / FKM / EPDM	0.03	0.03
TAN104BUET050V0	Aluminium	¼"	5	NA	0	10	NBR / FKM / EPDM	0.73	--
TAN104BNCW012V0	Aluminium	¼"	1.2	NA	0	10	NBR / FKM / EPDM	0.04	--
TBN014BNCW025V0	Brass	⅛"	2.5	NA	0	3	NBR / FKM / EPDM	0.16	--
TBN004BNCW012V0	Brass	⅛"	1.2	NA	0	10	NBR / FKM / EPDM	0.04	--
TBN104BNCW012V0	Brass	¼"	1.2	NA	0	10	NBR / FKM / EPDM	0.04	--
TBN103BNCW012V0	Brass	¼"	1.2	NA	0	7	NBR / FKM / EPDM	0.04	--
TBN114BNCW025V0	Brass	¼"	1.2	NA	0	3	NBR / FKM / EPDM	0.04	--
TCN004BNCW012V0	SS304	⅛"	1.2	NA	0	10	NBR / FKM / EPDM	0.04	--
TCN103BNCW016V0	SS304	¼"	1.2	NA	0	7	NBR / FKM / EPDM	0.04	--
TCN003BNEW080V0	SS304	⅛"	1.2	NA	0	7	NBR / FKM / EPDM	0.04	--
TCN718BNEW009V0	SS304	⅜"	0.9	NA	0	40	NBR / FKM / EPDM	0.03	--



Valve Specifications

Model No. :	D6J146NNVW035C1V0	D6J144NZVW030C1V0
Valve Position :	Normally Close	Normally Open
Type :	2/2 Direct Acting	
Orifice :	3.5 mm	3 mm
Pressure :	0 - 21 bar	0 - 18 bar
Body Material :	SS 316	
Port Connection :	1/4" NPT(F)	
Media :	Petrol/ Diesel/ SKO/ HSD	
Ambient Temperature :	-20°C to 70°C	
Seal Material :	Viton GLT	
Media Temp. :	-30°C to 230°C	

Coil Specification

Operating Voltage :	230V AC
Power Consumption :	15W
Coil Features :	High Reliability Unaffected by Voltage Surges. Easy coil changes coil lockable in 4X90 position or freely movable in between as require.
Coil Housing :	IP65 Epoxy square coil, IP65 Metallic round enclosure, IP67 Flameproof enclosure, IP68 Weatherproof enclosure.

Port Connection

1 - Output, 2 - Input

Valve Model No.	Function	Symbol
D6J146NNVW035C1V0	Single Solenoid Spring Return	
D6J144NZVW030C1V0	Single Solenoid Spring Return	

Features

- Bubble tight shut off
- Mounts in any position
- Vibration resistance up to 9g
- Suitable for high speed cycling
- Speed up to 600 cycles/ min
- Life >10 million cycles

Dimension Drawing (All dimensions in mm)

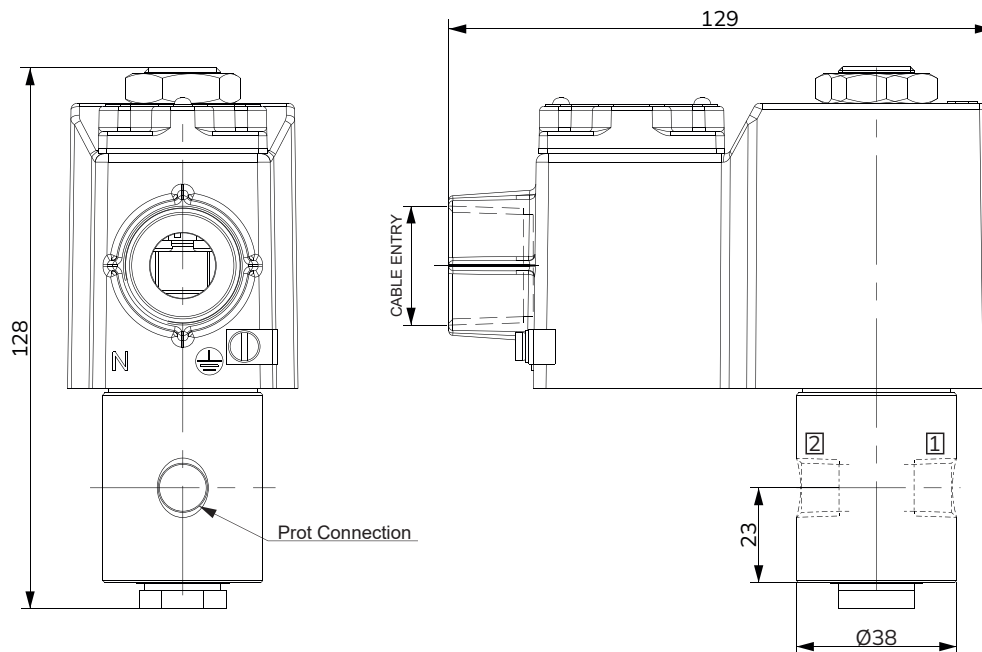

DIRECT ACTING SOLENOID VALVE MODEL IDENTIFICATION CHART

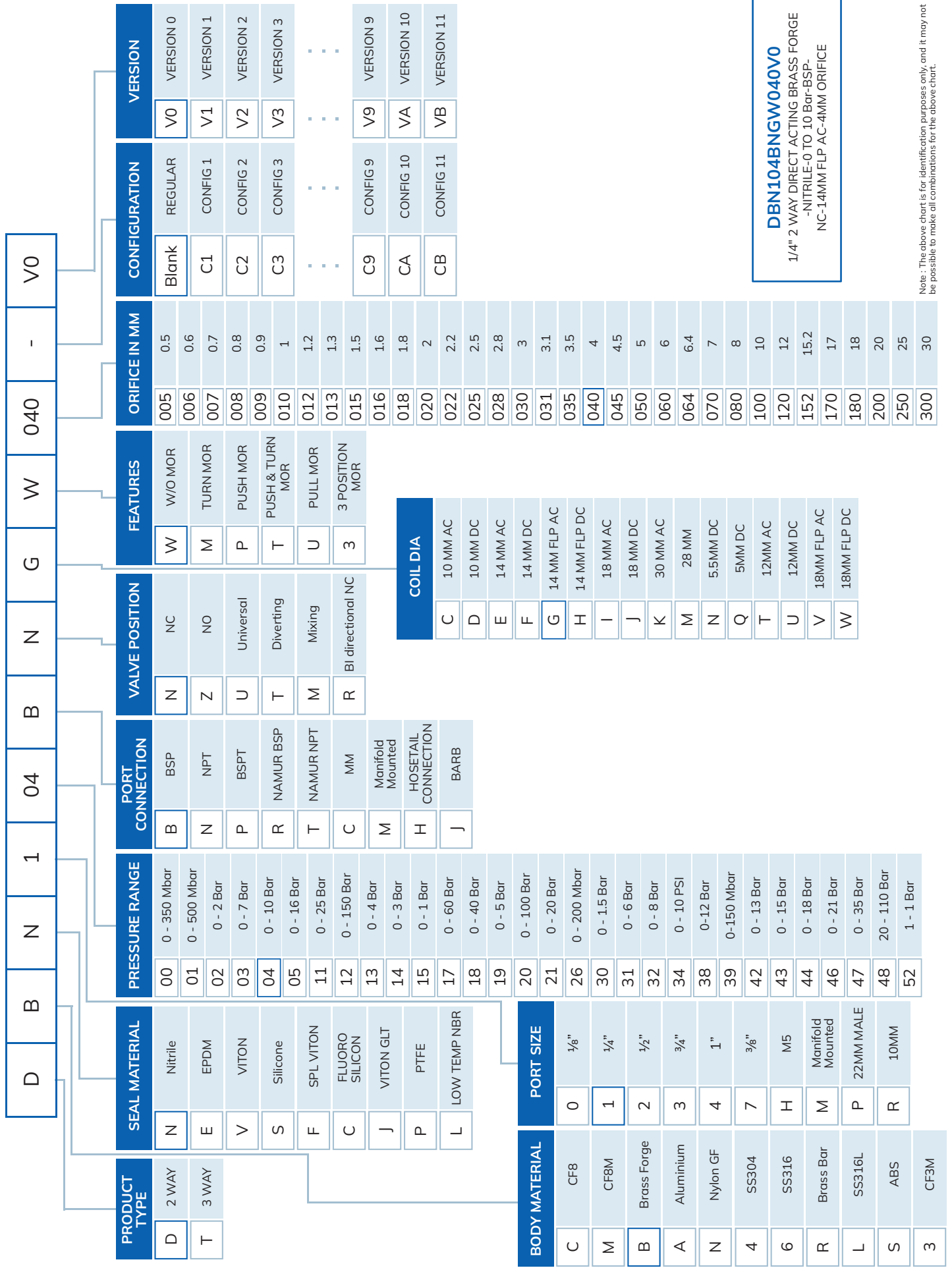

DBN104BNGW040V0
 1/4" 2 WAY DIRECT ACTING BRASS FORGE
 -NITRILE-0 TO 10 Bar-BSP-
 NC-14MM FLP AC-4MM ORIFICE

Note : The above chart is for identification purposes only, and it may not be possible to make all combinations for the above chart.

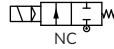

Specifications

Port :	½" - BSP Thread	Operating Voltage :	12V DC	24V DC	24V AC	230V AC
End Connection :	Screwed	Power Consumption :	10W	11W	10W	10W
Body Material :	Nylon GF	Coil Features :	High Reliability Unaffected by Voltage Surges. Easy coil changes coil lockable in 4X90 position or freely movable in between as require.			
Diaphragm :	FPM	Coil Housing :	IP65 Epoxy square coil, IP65 Metallic round enclosure.			
Media Temp :	5°C to 50°C	Other Specification Data :	Available on Request – Available for vacuum application upto 450mm Hg			
Circumstance Temp :	-10°C to 70°C					
Media :	Water, Liquid Media, Gaseous Media					
Main Features :	Internal Parts are in superior corrosion resistance steel. and Without Mor					

NOTE: Use of filter in the inlet port is recommended.
Specification may change without prior notice.

Technical Data

Valve Model No.	Body Material	Pipe (Inch)	Orifice (mm)	Min. Operating Pressure PSI	Max. Operating Pressure PSI	Seal & Diaphragm Material	Flow Factor Kv m ³ / hr
SNM251BNFW080V0	Nylon GF	½"	8	0	20	FPM	1

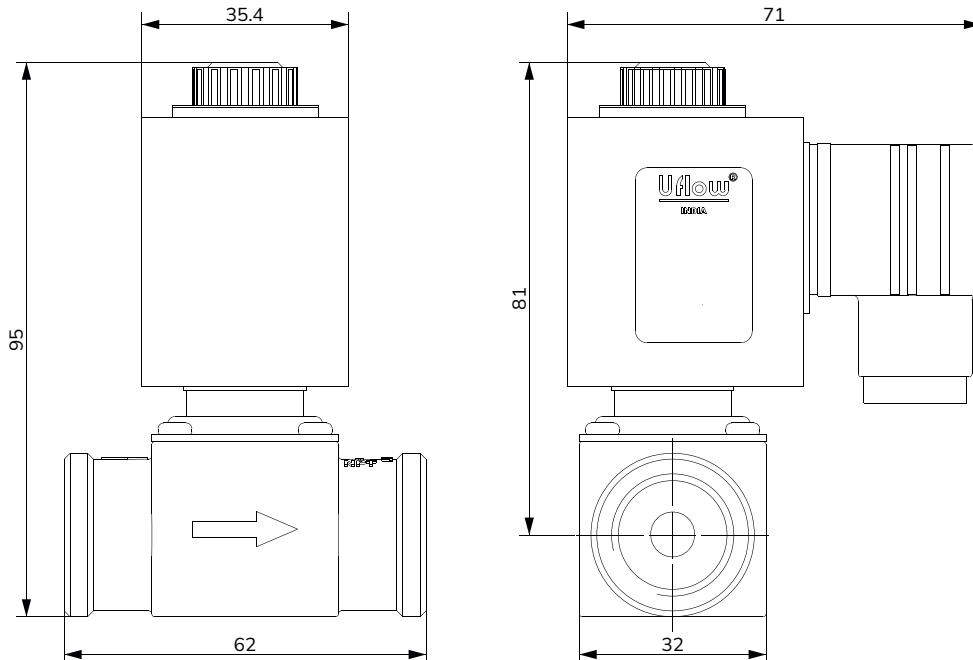

* All dimensions are approx

DIRECT ACTING MEDIA SEPRETED VALVE MODEL IDENTIFICATION CHART

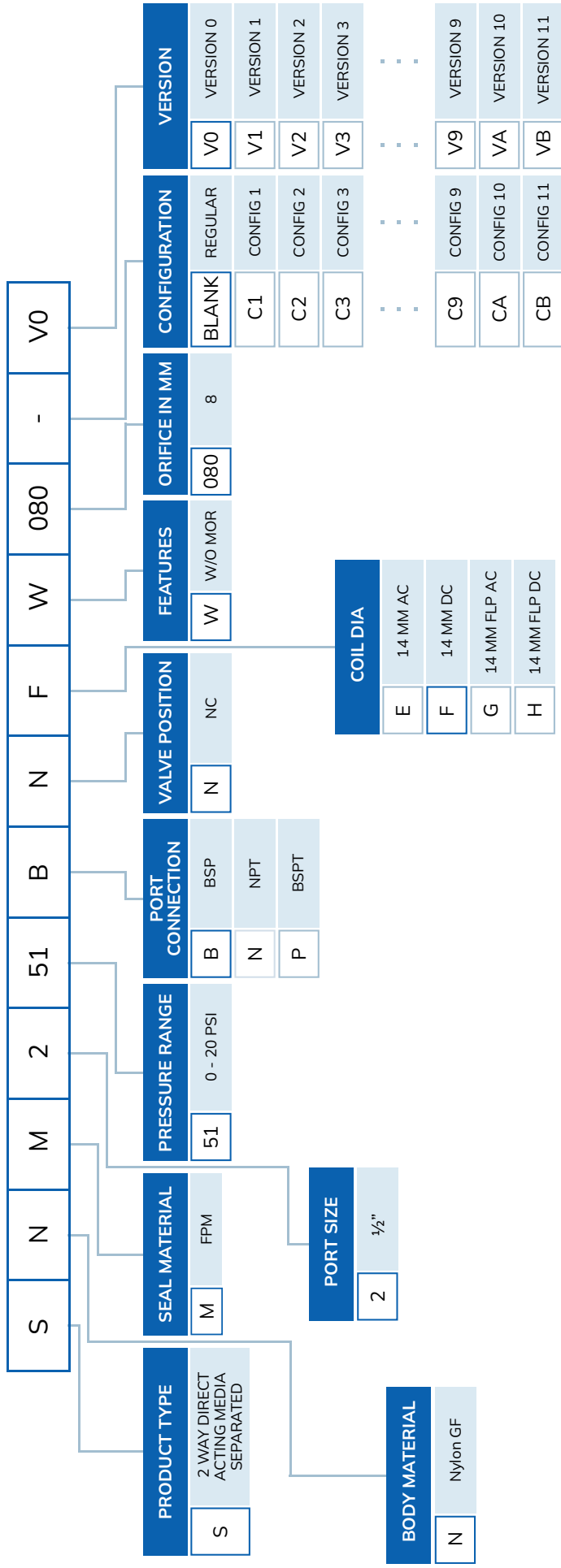

SNM251BNFW080V0
 1/2" 2 WAY DIRECT ACTING MEDIA SEPARATED Nylon GF-FPM-0 TO 20 PSI-BSP-NC-14MM DC-8MM ORIFICE

Note: The above chart is for identification purposes only, and it may not be possible to make all combinations for the above chart.

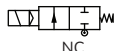

Specifications

Port :	1/2" - BSP Thread				Operating Voltage :	230AC
End Connection :	Screwed				Power Consumption :	9W
Body Material :	CF8				Coil Features :	High Reliability Unaffected by Voltage Surges. Easy coil changes coil lockable in 4X90 position or freely movable in between as require.
Diaphragm :	Nitrile (NBR)	EPDM	Viton (FKM)	SPL. Viton	Coil Housing :	IP65 Epoxy square coil
Media Temp :	-30°C to 90°C	-10°C to 140°C	-10°C to 180°C	-10°C to 180°C	Timing :	Cycle : 1 min to 120 min Adjustable Drain : 1 sec to 25 sec Adjustable
Circumstance Temp :	-10°C to 70°C					
Media :	Air, Water, Chemical, Gas					
Main Features :	Internal Parts are in superior corrosion resistance steel					

Features

- Designed specially to drain sludge and rust laden condensate
- Reliable all digital electronic circuitry
- ON and OFF timing adjustable

Technical Data

Valve Model No.	Timer Model No.	Body Material	Pipe (Inch)	Orifice (mm)	Min. Operating Pressure Kg/cm ²	Max. Operating Pressure Kg/cm ²	Seal & Diaphragm Material	Flow Factor Kv m ³ / hr
ACN205BNEW015V0	T11ANV0	CF8	1/2"	1.5	0	16	NBR / EPDM / Viton / SPL. Viton	0.07
ACN205BNEW030V0	T11ANV0	CF8	1/2"	3	0	16	NBR / EPDM / Viton / SPL. Viton	0.20

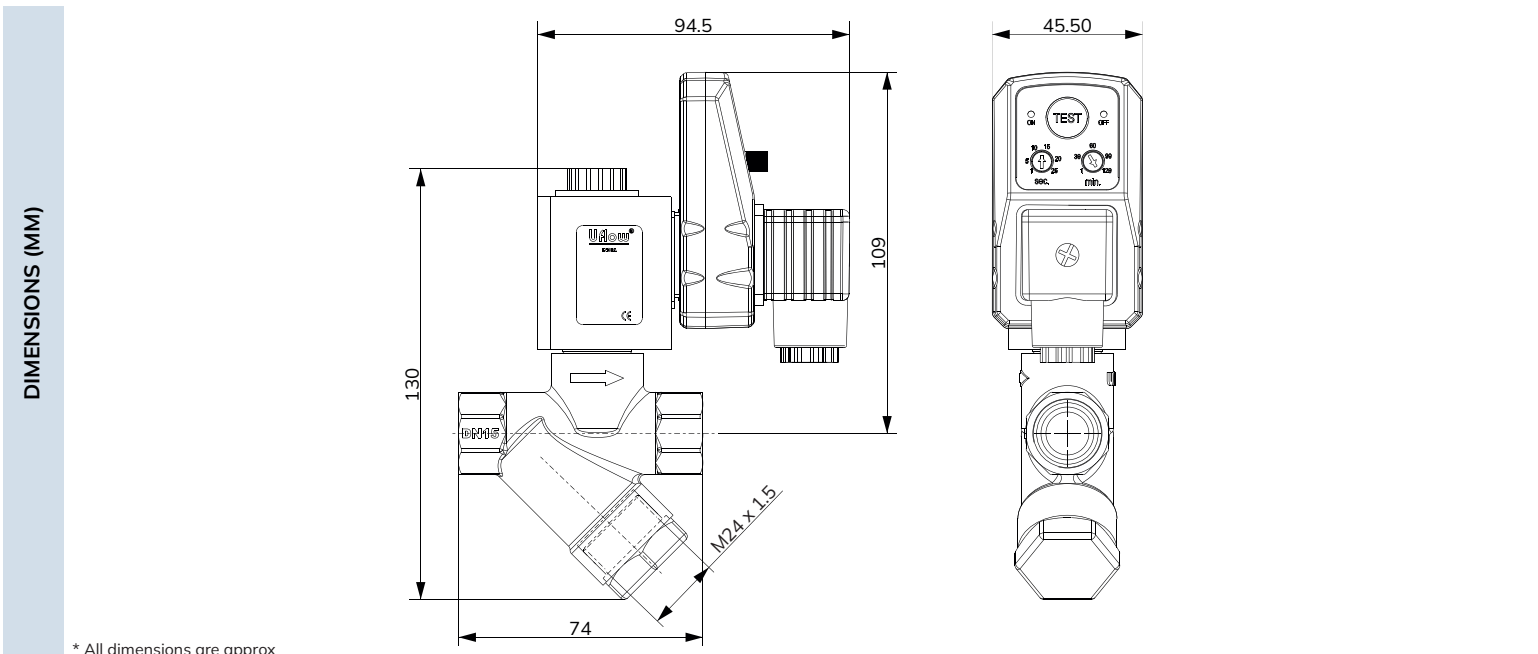

2 WAY DIRECT ACTING AUTO DRAIN MODEL IDENTIFICATION CHART

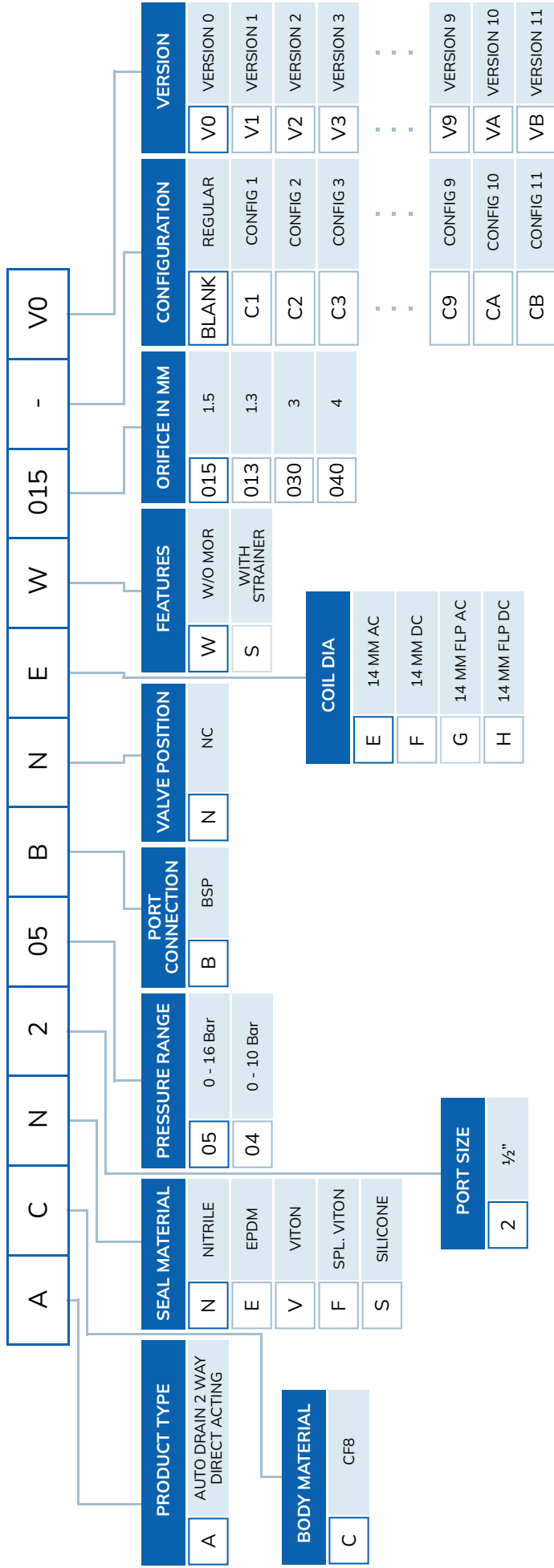

ACN205BNEW015V0
 1/2" AUTO DRAIN 2 WAY DIRECT ACTING CF8-NITRILE-0 TO 16 Bar-BSP-NC-14MM AC-1.5MM ORIFICE

Note: The above chart is for identification purposes only, and it may not be possible to make all combinations for the above chart.

TIMER MODEL IDENTIFICATION CHART

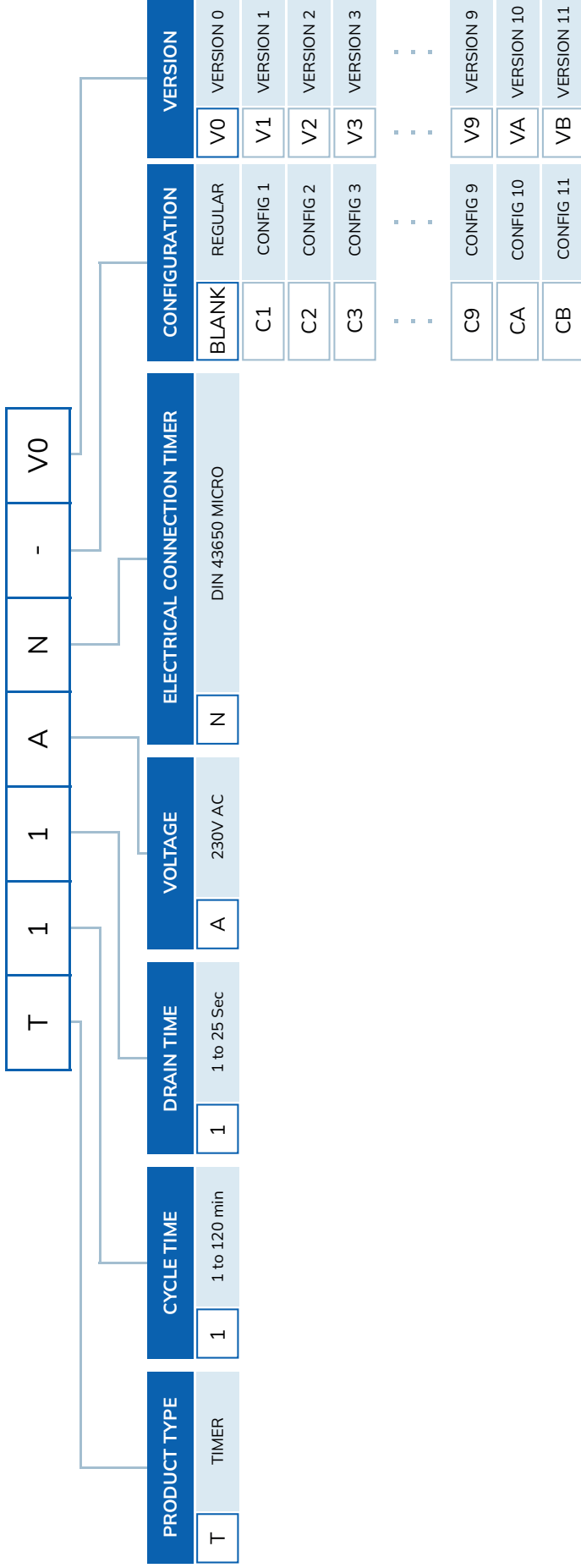

T11ANVO
 TIMER 1 TO 120 MIN-1TO 25 SEC-230V AC-DIN 43650 MICRO

Note: The above chart is for identification purposes only, and it may not be possible to make all combinations for the above chart.

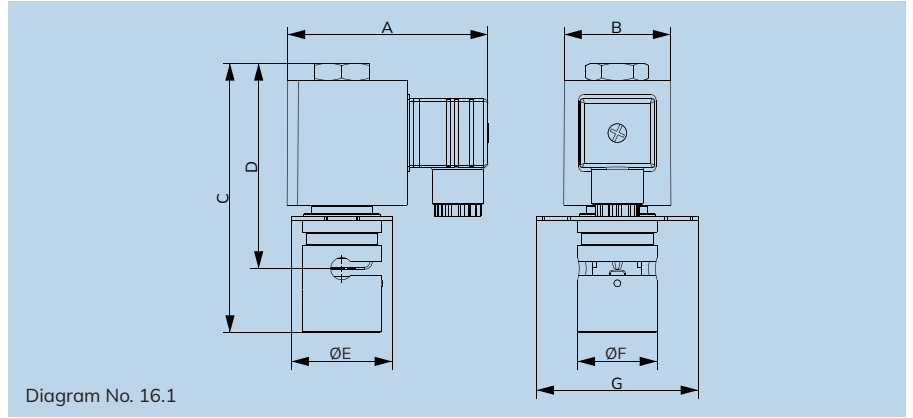
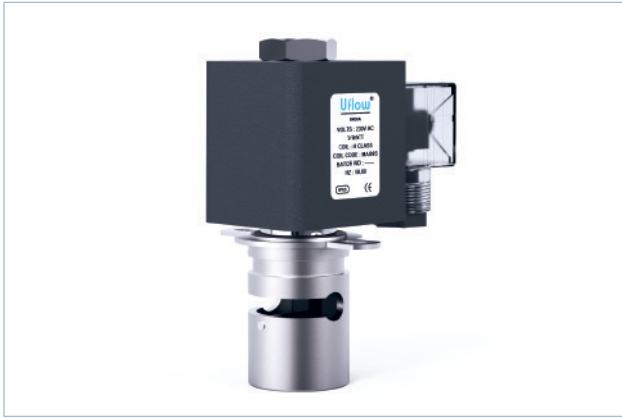

Diagram No. 16.1

Specifications

Body :	Aluminum		
Internal Parts :	Stainless Steel		
Sealing :	Polyamide		
Seats, Core Tube, Springs	Stainless Steel		
Operating Voltage :	12V DC	24V DC	230V AC
Power Consumption :	20W	20W	20W
Application :	Water, Food, Gas, Medicine, Hospital & Health, Petro Chemistry		
Coil Housing :	Epoxy Square Coil		
Coil Features :	High Reliability Unaffected by Voltage Surges. Easy coil changes coil lockable in 4X90 position or freely movable in between as require.		
Other Specification Data :	Available on Request		

Dimension

All dimensions are approx.

Model No.	Diagram No.	A	B	C	D	ØE	ØF	F
PA08NYV0	16.1	76	40	102	78	38	30	61
PA08ZYV0	16.1	76	40	102	88	38	30	61

Features

- There are different models for different tube diameter and stiffness.
- Solenoid valves are used with the filter.
- Bobbin up in a vertical position should be preferred.
- This product in the differential pressure is 0 bar.
- The metal is used in particular to fluid communication undesirable.
- Usage Areas : Dialysis Machines, Pharmaceutical Industry, Medical Laboratories, Food Industry, Bioreactors, Blood Transf Unit, Tissu Transplantation Units,
- Stiffness of Hose: Max. 55 Shore A

Advantages

- Low Pressure Loss: Pinch valves at are very few pressure loss. This low pressure system reason it is preferred to perform the flow without causing further loss pressure.
- Use Amenities Containing Particulate in Fluids: Pinch valves use in streams containing small particles is an advantage. small parts such as sand can lead to clogging or orifice solenoid coil blubbering normal valves. The use of pinch valves is an advantage in such cases.
- Ease of change: In case of any malfunction in a very easy way pinch valves even the is possible to provide changes without the need stopping the flow.
- Being the Just Fow in Contact With Hosepipe: Is no material or seal outside Hose in pinch valves to be in contact with the fluid. This feature is of great importance for chemicals that are react with a hygienic risks flow or

Technical Data

Symbol	Model No.	Tubings		Min. Tubings Wall Thickness	Max. Operating Pressure Kg/cm ²
		Inside Diameter	Outside Diameter		
 NC	PA09NYV0	6	9	1.5	0.5
	PA09ZYV0	6	9	1.5	0.5
	PA08NYV0	5	8	1.5	0.5
	PA08ZYV0	5	8	1.5	0.5
 NO	PA07NYV0	4	7	1.5	0.5
	PA07ZYV0	4	7	1.5	0.5
	PA06NYV0	3	6	1.5	0.5
	PA06ZYV0	3	6	1.5	0.5

PINCH TYPE SOLENOID VALVE MODEL IDENTIFICATION CHART

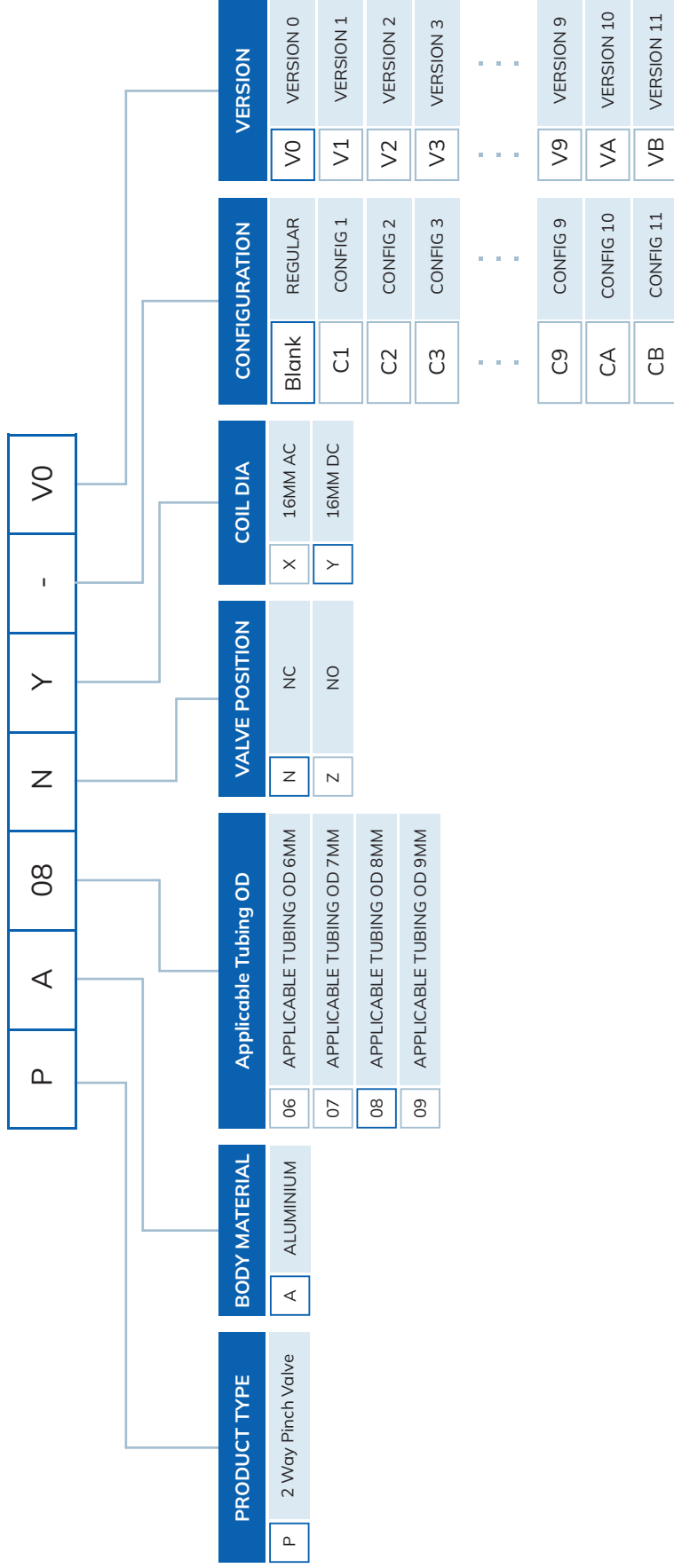

PA08NYV0

2 WAY PINCH VALVE APPLICABLE TUBING OD 8MM Aluminium-NC-16MM DC

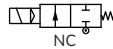

Valve Specifications

Port :	½" (Available in BSP / BSPT / NPT)			
End Connection :	Screwed			
Body Material :	Brass Forge			
Seal Material :	Nitrile (NBR)	EPDM	Viton (FKM)	PTFE
Media Temp :	-30°C to 90°C	-10°C to 140°C	-10°C to 180°C	-10°C to 180°C
Circumstance Temp :	-10°C to 70°C			
Media :	Air, Water, Chemical, Gas, Oil, Diesel, Kerosene, LPG.			
Main Features :	Internal Parts Are In Superior Corrosion Resistance Steel.			

Actuator Specifications

Cover :	Aluminium
Control Plate :	Aluminium
Working Pressure	3.5 - 7 Bar
Seal Material	Nitrile

NOTE: Use of filter in the inlet port is recommended.
Specification may change without prior notice.

Technical Data

Valve Model No.	Body Material	Pipe (Inch)	Orifice (mm)	Min. Operating Pressure Kg/cm ²	Max. Operating Pressure Kg/cm ²	Seal & Diaphragm Material	Flow Factor Kv m ³ / hr
CBN205FBNAV0	Brass	½"	12	0	16	NBR / EPDM / VITON / PTFE	2.5

DIMENSIONS (MM)

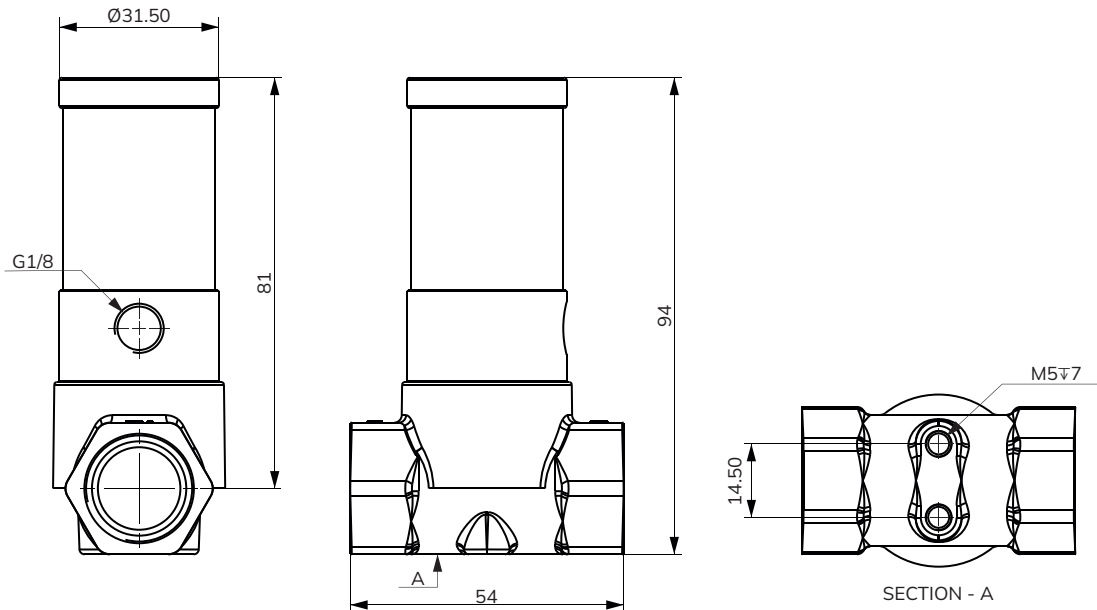

* All dimensions are approx

2 WAY CONTROL VALVE WITH ALUMINUM OPERATOR MODEL IDENTIFICATION CHART

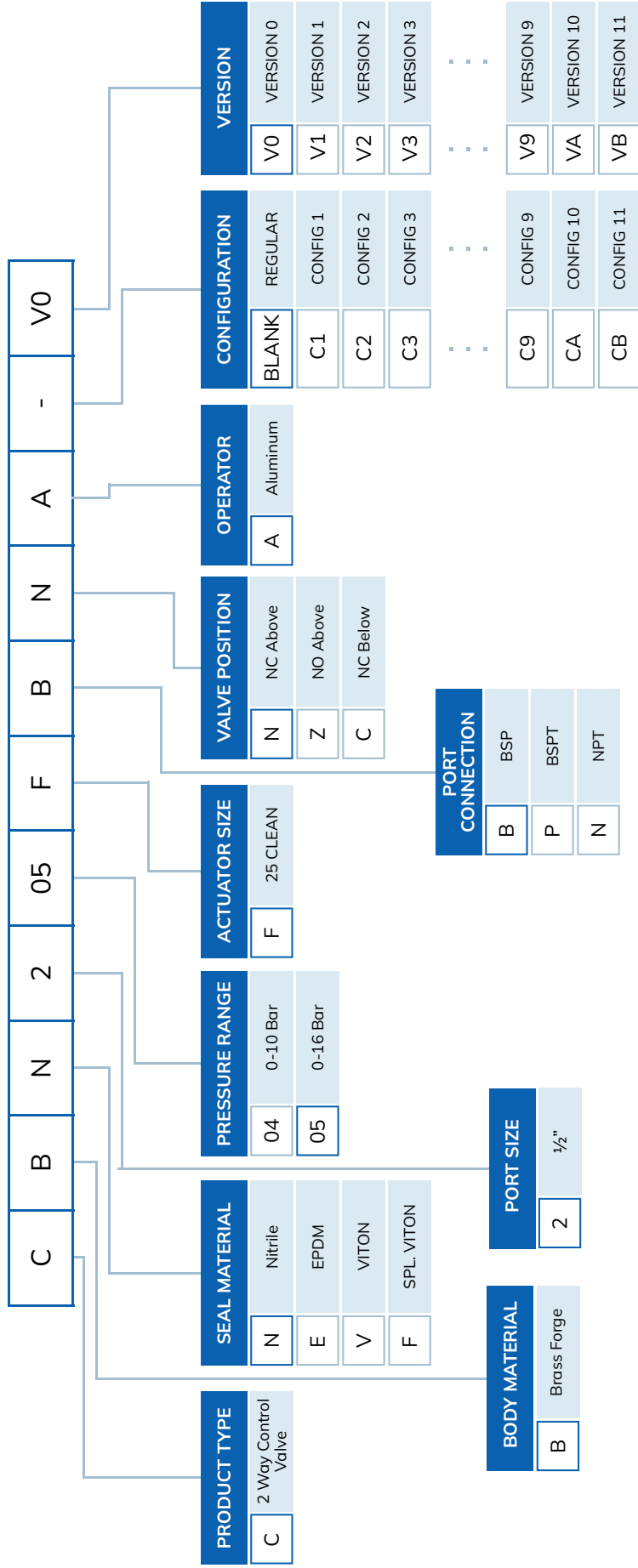

CBN205FBNAVO

1/2" 2 WAY CONTROL VALVE ALUMINUM OPERATOR BRASS-NITRILE-0 TO 16 Bar-25 CLEAN-BSP-NC ABOVE

Note: The above chart is for identification purposes only, and it may not be possible to make all combinations for the above chart.



**SOLENOID COIL
SERIES**

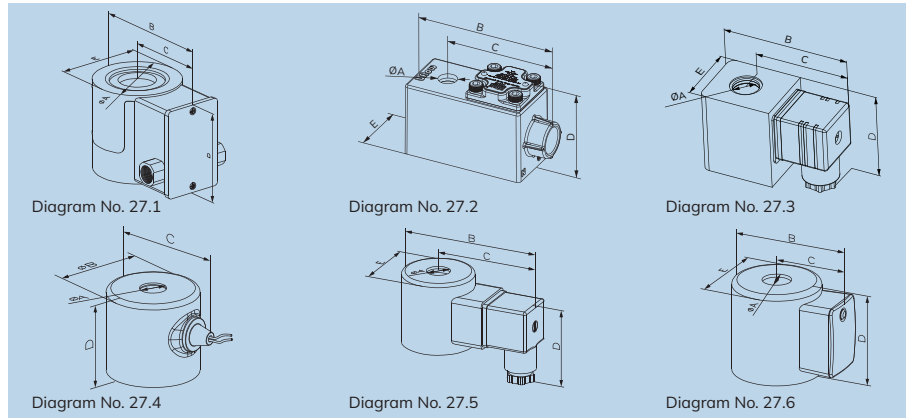

Specifications

Port :	IP65 Epoxy moulded with led din connector, Metallic round shape with lead wire, IP67 Flame proof junction box, IP68 weather proof metallic round enclosure, IP67 Weather proof junction box, IP67 Explosion proof junction box with bottom cable entry, IP67 Explosion proof junction box with horizontal cable entry				
Coil Bore Diameter :	5mm, 8mm, 10mm, 12mm, 14mm, 16mm, 18mm, 28mm, 30mm				
Class :	H-Class, Weather Proof IP68, Flame Proof IP67				
Voltage :	24AC	110AC	230AC	12DC	24DC
Watt :	9W	8W / 30W	8W / 17W / 30W	10W / 6W	11W / 6W
Duty :	Non Latching - Continues Duty - 100%, Latching - Required pulse in millisecond.				
Main Features :	Surge Suppressor for High Wattage Coil. 90% Power saver series also available, Latching Coil.				
Latching Coil Benefits :	<p>Remote or Battery operated application</p> <p>A situation where a valve needs to be open/actuated for an extended period of time</p> <p>Continuous operation of solenoid coil generates heat, and certain portion of it get dissipated into the media flowing through the valve, hence to avoid such heat generation and dissipation, Latching coil is recommended.</p> <p>End connections in Flame Proof Junction Box , Weather Proof Junction Box are available in</p> <ul style="list-style-type: none"> - 1/2" NPT - M20 X 1.5 				

Dimension (All dimensions in mm)

All Dimensions are approx.

Type	Diagram No.	A	B	C	D	E
Epoxy Moulded Round Coil	27.1	30.5	105	69	75	71
Flame proof Junction Box IP67	27.2	14.5	112	86	63	52
Epoxy Moulded With LED Din Connector	27.3	14.5	71	53	49	36
Epoxy Moulded With LED Din Connector	27.3	10.3	65	52	46	26
Metallic Round Enclosure With Lead Wire	27.4	14.5	44	57	48	-
Metallic Round Enclosure With Lead Wire	27.4	10.3	28	34	30	-
Metallic Round Enclosure LED Din Connector	27.5	14.5	85	63	50	44
Epoxy Moulded With LED Din Connector	27.3	18.5	84	57	58	54
Metallic Round Enclosure With Lead Wire	27.4	18.5	50	62	61	-
Metallic Round Enclosure Power Saver	27.6	14.5	61	39	49	44
Weather Proof Junction Box IP67	27.2	18.5	130	102	67	55
Weather Proof Round Enclosure	27.4	12	29	-	48	-

- Metallic Round Enclosure Weather proof coils complies as per IS/IEC-60529-2001 (Approved by ERDA) (IP-68).
- Weather proof junction Box coils complies as per IS/IEC-60529-2001 (Approved by ERDA) (IP-67).
- Flame Proof Junction Box conforming as per Is/IEC-60079-1:2007 (Approved by ELCA).
- Coils are suitable for IIC Atmosphere Condition (Zone 1&2 Gas Group).
- Flame Proof Series are followed under BIS.
- For Flame Proof Condition Working Environment Coils are licensed under PESO.
- TRCU certified product available on request
- CE certified

We Are Introducing New Power Saver Series (VA Series) Served by Our R&D Department, This New Latest Technology Saves Up to 90% of Power.

BENEFITS:

- Reduce Battery Drain
- Reduce Wiring Cost
- Reduce Temperature Rise
- Low Wattage
- Energy Savings
- Improve Valve Performance at High Pressure

SOLENOID COIL MODEL IDENTIFICATION CHART

PRODUCT TYPE		VOLTAGE	COIL BORE	WATTAGE	CONNECTION	CONFIGURATION	VERSION
R	ROUND SOLENOID	A 230V AC	F 08MM	00 00.00	S SOCKET	BLANK	- VERSION 0
M	EPOXY SOLENOID	B 24V AC	G 10MM	01 01.00	L LEAD WIRE	C1	V1 VERSION 1
W	WEATHER PROOF SOLENOID	C 42V AC	I 14MM	02 02.00	H ½" NPT	C2	V2 VERSION 2
F	FLAME PROOF JUNCTION BOX	D 48V AC	K 18MM	03 03.00	M M20 X 1.5	C3	V3 VERSION 3
P	POWER SAVER SOLENOID	E 110V AC	P 28MM	04 04.00	T ¾" NPT
B	IP67 WEATHER PROOF JUNCTION BOX	F 12V DC	Q 30MM	05 05.00	B BARE LUG	C9	V9 VERSION 9
S	SQUARE	G 24V DC	E 05MM	06 06.00	G Automotive Connector Male	CA	VA VERSION 10
		I 400V FAC	D 12MM	07 07.00	A Automotive Connector Female	CB	VB VERSION 11
		J 230V FAC					
		M 24V FAC					
		N 415V AC					
		O 36V DC					
		P 110V FAC		08 08.00			
		Q 110V DC		09 09.00			
		R 48V DC		10 10.00			
		S 120V AC		11 11.00			
		T 28V DC		12 12.00			
		U 6V DC		...			
		V 280V AC		33 33.00			
		W 9V DC					
		X 256V DC					
		Y 330V FAC					
		Z 220V DC					
		1 415V FAC					
		2 400V AC					
		3 480V AC					
		4 5V DC					
		5 5V AC					
		6 380V AC					
		7 200V AC					

RAI08L
ROUND SOLENOID 230V AC 14MM Ø8W LEAD WIRE

Note: The above chart is for identification purposes only, and it may not be possible to make all combinations for the above chart.

LATCHING SOLENOID COIL MODEL IDENTIFICATION CHART

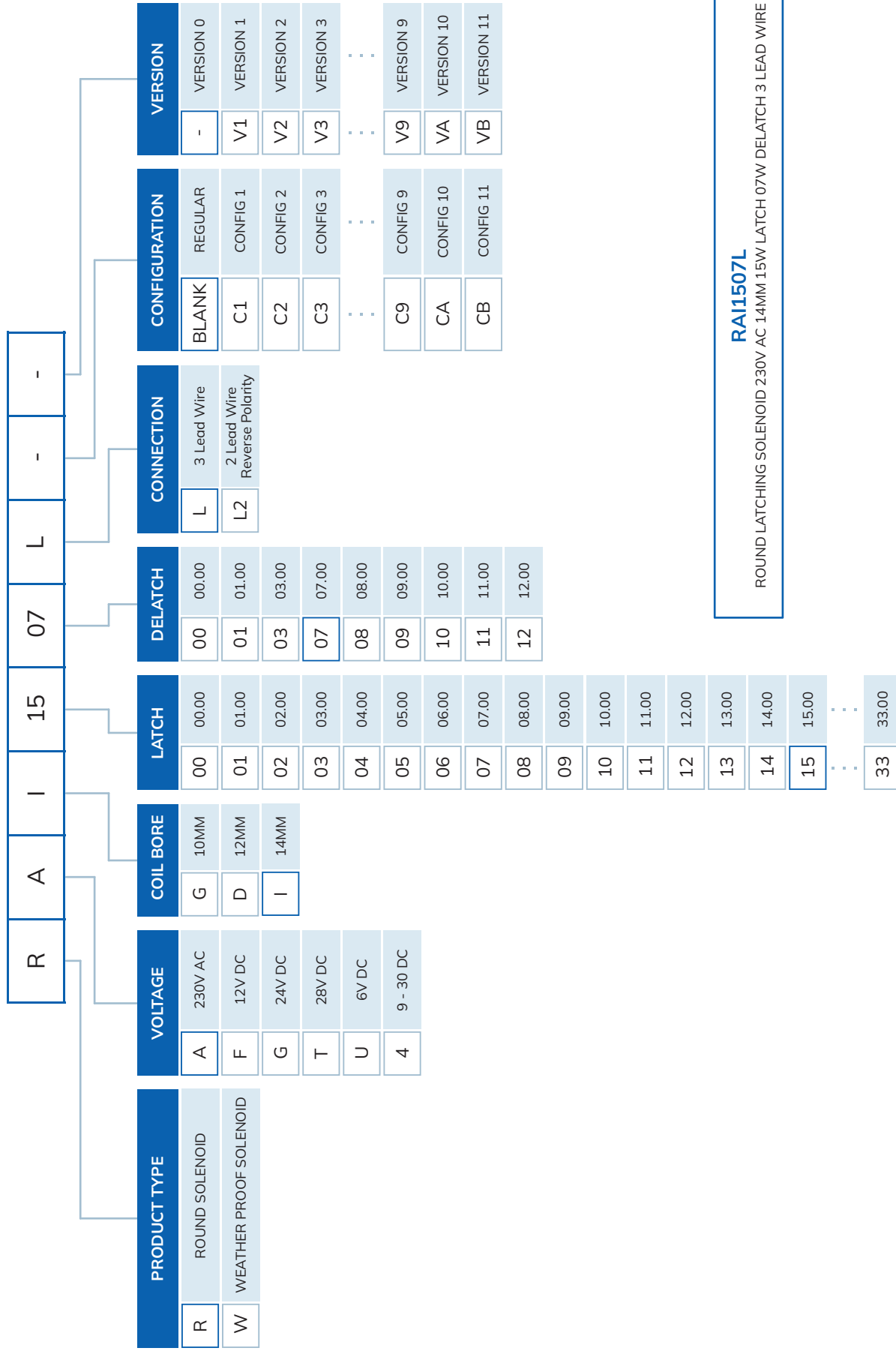

RAI1507L
 ROUND LATCHING SOLENOID 230V AC 14MM 15W LATCH 07W DELATCH 3 LEAD WIRE

EXPLOSION PROOF SOLENOID ACTUATOR MODEL IDENTIFICATION CHART

		X1	X2	X3	X4	X5	X6	X7	X8				
		COIL BORE		WATTAGE		CONNECTION		BODY MATERIAL		CONFIGURATION		VERSION	
TYPE	VOLTAGE												
T37	TR CU Solenoid Explosion Proof Horizontal Cable Entry	A	230V AC	I	14MM	00	00.00	D	1/2" National Pipe Taper Thread	A	Aluminum	BLANK	VERSION 0
T47	TR CU Solenoid Explosion Proof Bottom Cable Entry	B	24V AC	K	18 MM	01	01.00	E	3/4" National Pipe Taper Thread	C	CF8	C1	VERSION 1
		C	42V AC			02	02.00	F	M20 x 1.5 Metric Thread	M	CF8M	C2	VERSION 2
		D	48V AC			03	03.00	G	3/4" Electrical Thread	L	CF3M	C3	VERSION 3
		E	110V AC			04	04.00	H	M25x1.5 Metric Thread				...
		F	12V DC			05	05.00						...
		G	24V DC			06	06.00						...
		I	400V FAC			07	07.00					C9	CONFIG 9
		J	230V FAC			08	08.00					CA	CONFIG 10
		M	24V FAC			09	09.00					CB	CONFIG 11
		N	415V AC			10	10.00						VERSION 9
		O	36V DC			11	11.00						VERSION 10
		P	110V FAC			12	12.00						VERSION 11
		Q	110V DC			
		R	48V DC			
		S	120V AC			
		T	28V DC			
		U	6V DC			
		V	280V AC			
		W	9V DC			
		X	256V DC			
		Y	330V FAC			
		Z	220V DC			
		1	415V FAC			
		2	400V AC			
		3	480V AC			
		4	5V DC			
		5	5V AC			
		6	380V AC			
		7	200V AC			

Structure of the coil symbol:

- X1: Type Solenoid Explosion Proof Horizontal Cable Entry, Solenoid Explosion Proof Bottom Cable Entry - Type 37 & Type 47
- X2: Voltage (5V to 480V) A to 7
- X3: Coil Bore or Dia 14mm & 18mm (I TO K)
- X4: Power (0 watt to 22 watt)
- X5: Connection Type (Electric connection type D TO H)
- X6: Body Material (A TO L)
- X7: Configuration (C1 TO CB)
- X8: Version (V0-VB)

Type 37 - Temperature Class of Horizontal Cable Gland - T6... T3
Type 47 - Lower Cable Gland Temperature Class - T6... T3



ATEX EXPLOSION PROOF SOLENOID ACTUATOR MODEL IDENTIFICATION CHART

		X1	X2	X3	X4	X5	X6	X7	X8				
		COIL BORE		WATTAGE		CONNECTION		BODY MATERIAL		CONFIGURATION		VERSION	
TYPE	VOLTAGE	COIL BORE		WATTAGE		CONNECTION		BODY MATERIAL		CONFIGURATION		VERSION	
E37	A 230V AC	I 14MM	00	D	A	BLANK	V0	ATEX Solenoid Explosion Proof Horizontal Cable Entry					
E47	B 24V AC	K 18MM	01	E	C	C1	V1	ATEX Solenoid Explosion Proof Bottom Cable Entry					
	C 42V AC		02	F	M	C2	V2						
	D 48V AC		03	G	L	C3	V3						
	E 110V AC		04	H							
	F 12V DC		05								
	G 24V DC		06								
	I 400V FAC		07								
	J 230V FAC		08								
	M 24V FAC		09								
	N 415V AC		10								
	O 36V DC		11								
	P 110V FAC		12								
	Q 110V DC							
	R 48V DC							
	S 120V AC		22								
	T 28V DC										
	U 6V DC										
	V 280V AC										
	W 9V DC										
	X 256V DC										
	Y 330V FAC										
	Z 220V DC										
	1 415V FAC										
	2 400V AC										
	3 480V AC										
	4 5V DC										
	5 5V AC										
	6 380V AC										
	7 200V AC										

Structure of the coil symbol:
X1: Type Solenoid Explosion Proof Horizontal Cable Entry, Solenoid Explosion Proof Bottom Cable Entry - Type 37 & Type 47
X2: Voltage (5V to 480V) A to 7
X3: Coil Bore or Dia 14mm & 18mm (I TO K)
X4: Power (0 watt to 22 watt)
X5: Connection Type (Electric connection type D TO H)
X6: Body Material (A TO L)
X7: Configuration (C1 TO CB)
X8: Version (V0-VB)

Type 37 - Temperature Class of Horizontal Cable Gland - T6... T3
Type 47 - Lower Cable Gland Temperature Class - T6... T3





**ANGLE SEAT VALVE
SERIES**



Angle seat valves are 2/2 way pneumatically actuated piston valves. The piston actuator provides a linear motion to lift the seal off its seat. Because the seat is positioned under an angle, the flow is minimally impeded in the open position, resulting in an excellent flow rate and a low pressure loss. They are used to regulate the flow of liquids, gases, steam, vacuum and even aggressive fluids. They can also operate with high temperatures and high viscosity media, even under zero differential pressures. The robust design makes UFLOW angle seat valves a popular choice for harsh applications and they have very high life cycle. Therefore they are an excellent alternative to Ball valves with actuator combo. These valves are also suitable alternatives for solenoid valves, especially with contaminated, viscous media where typical solenoid valves would fail. They may be operated using a single acting or double acting configuration, which has an influence on its pressure rating.

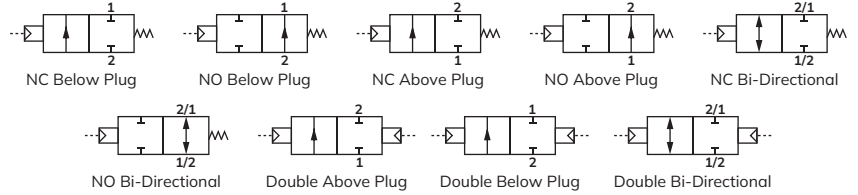

Specifications

Port :	1/2", 3/4", 1", 1 1/4", 1 1/2", 2" & 2 1/2" (Available in BSP / NPT)
End Connection :	Screwed / Flange / Tri-Clamp / Socket Weld
Body & Sleeve Material :	SS ASTM A351 Grade CF8 / CF8M / CF3M
Seal :	PTFE / PEEK / VITON
Shaft :	SS304 / SS316
Circumstance Temp :	-10°C to 70°C
Media Temp :	-10°C to 180°C
Other Specification Data:	Available on request - Adjust Stroke Limiter - Position Sensor

Features

- Convertible from single Acting to Double Acting.
- Multiple Function with the same operator - NC / NO / Bi-Directional.
- Rotatable Actuator- 360°.
- Transparent dome for visual confirmation of the valve's position/state
- Lubricated air not essential.
- Flow direction below or above the seat.
- Media: Steam, Air, Water, Chemical, Gases, Oil, Diesel, Hot Water.
- Application: Steam, Autoclave and Sterilizer, Ink and Paint dispensing, Industrial compressor bottling and dispensing equipment, textile dying and drying and pharmaceutical.

Actuator Type

Cover :	Nylon Glass-Filled (Corrosion resistive) with SS Liner
Seal :	NBR / VITON
Working Pressure :	Refer Below Pressure Chart Table
Life :	Three Million Cycle Tested
Other Technical Data :	Available on Request

Section View



Dimension With Screwed End (All dimensions in mm)

All Dimensions are approx.

Model No.	Actuator	Port Size	Diagram No.	A	B	C	D	E	F	G	H	I
ACP2054BNV1	40	1/2"	28.1	65	144	131	154	65	24	G 3/4"	32	M5
ACP2055BNV1	50	1/2"	28.1	65	153	141	163	70	24	G 3/4"	32	M5
ACP2056BNV1	63	1/2"	28.1	65	171	158	181	85	24	G 3/4"	32	M5
ACP3054BNV1	40	3/4"	28.1	77	150	134	161	65	24	G 1/2"	32	M5
ACP3055BNV1	50	3/4"	28.1	77	160	144	171	70	24	G 1/2"	32	M5
ACP3056BNV1	63	3/4"	28.1	77	177	161	187	85	24	G 1/2"	32	M5
ACP4055BNV1	50	1"	28.1	89	177	157	185	70	24	G 1/2"	32	M5
ACP4056BNV1	63	1"	28.1	89	194	174	202	85	24	G 1/2"	32	M5
ACP4059BNV1	90	1"	28.1	89	221	201	229	126	24	G 1/2"	32	M5
ACP5056BNV1	63	1 1/4"	28.1	110	199	175	209	85	24	G 3/4"	32	M5
ACP5059BNV1	90	1 1/4"	28.1	110	225	201	236	126	24	G 3/4"	32	M5
ACP6059BNV1	90	1 1/2"	28.1	124	239	211	247	126	24	G 3/4"	32	M5
ACP8059BNV1	90	2"	28.1	150	260	227	269	126	24	G 3/4"	32	M5
ACP9039BNV1	90	2 1/2"	28.1	168	281	239	261	126	24	G 3/4"	32	M5

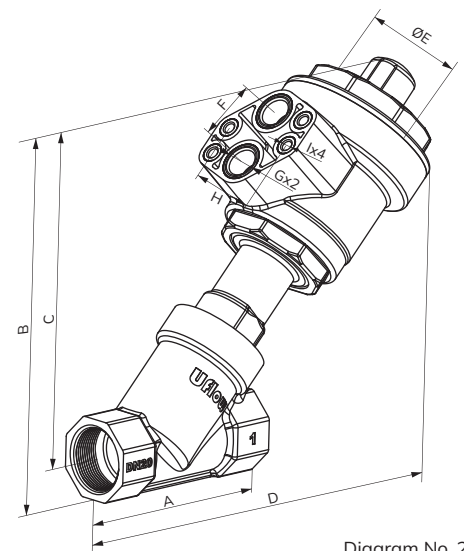
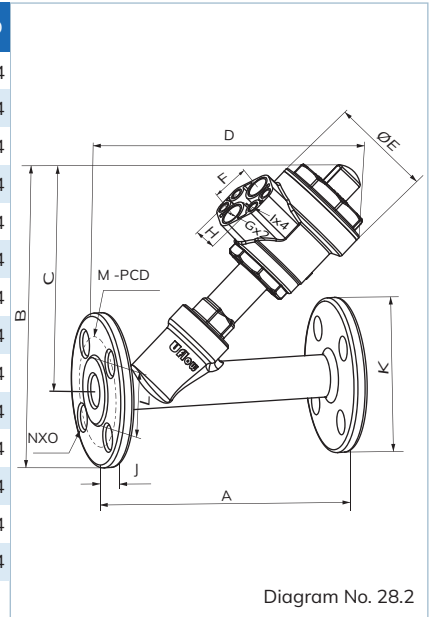

Diagram No. 28.1

Dimension With Flange (ASME 16.5 #150) (All dimensions in mm)

All Dimensions are approx.

Model No.	Actuator	Port Size	Diagram No.	A	B	C	D	E	F	G	H	I	J	K	L	M	NXO
ACP2054FNV1	40	½"	28.2	163	176	131	165	65	24	G¾"	32	M5	8	90	35	60	16X4
ACP2055FNV1	50	½"	28.2	163	186	141	175	70	24	G¾"	32	M5	8	90	35	60	16X4
ACP2056FNV1	63	½"	28.2	163	203	158	192	85	24	G¾"	32	M5	8	90	35	60	16X4
ACP3054FNV1	40	¾"	28.2	172	184	134	171	65	24	G¾"	32	M5	9	100	43	70	16X4
ACP3055FNV1	50	¾"	28.2	172	194	144	181	70	24	G¾"	32	M5	9	100	43	70	16X4
ACP3056FNV1	63	¾"	28.2	172	211	161	198	85	24	G¾"	32	M5	9	100	43	70	16X4
ACP4055FNV1	50	1"	28.2	181	212	157	196	70	24	G¾"	32	M5	10	110	51	79	16X4
ACP4056FNV1	63	1"	28.2	181	229	174	208	85	24	G¾"	32	M5	10	110	51	79	16X4
ACP4059FNV1	90	1"	28.2	181	256	201	240	126	24	G¾"	32	M5	10	110	51	79	16X4
ACP5056FNV1	63	1¼"	28.2	182	233	175	227	85	24	G¾"	32	M5	11	115	64	89	17X4
ACP5059FNV1	90	1¼"	28.2	182	259	202	254	126	24	G¾"	32	M5	11	115	64	89	17X4
ACP6059FNV1	90	1½"	28.2	212	274	211	269	126	24	G¾"	32	M5	13	125	73	98	16X4
ACP8059FNV1	90	2"	28.2	208	302	226	275	126	24	G¾"	32	M5	14	150	91	121	19X4
ACP9039FNV1	90	2½"	28.2	231	329	239	294	126	24	G¾"	32	M5	13	180	106	140	20X4



Dimension With Tri-Clamp (All dimensions in mm)

All Dimensions are approx.

Model No.	Actuator	Port Size	Diagram No.	A	B	C	D	E	F	G	H	I	J
ACP2054TNV1	40	½"	28.3	109	148	131	176	65	24	G¾"	32	M5	34
ACP2055TNV1	50	½"	28.3	109	158	141	185	70	24	G¾"	32	M5	34
ACP2056TNV1	63	½"	28.3	109	175	158	203	85	24	G¾"	32	M5	34
ACP3054TNV1	40	¾"	28.3	115	160	134	180	65	24	G¾"	32	M5	50
ACP3055TNV1	50	¾"	28.3	115	169	144	190	70	24	G¾"	32	M5	50
ACP3056TNV1	63	¾"	28.3	115	186	161	207	85	24	G¾"	32	M5	50
ACP4055TNV1	50	1"	28.3	130	182	157	206	70	24	G¾"	32	M5	50
ACP4056TNV1	63	1"	28.3	130	199	173	222	85	24	G¾"	32	M5	50
ACP4059TNV1	90	1"	28.3	130	225	200	249	126	24	G¾"	32	M5	50
ACP5056TNV1	63	1¼"	28.3	145	200	175	227	85	24	G¾"	32	M5	50
ACP5059TNV1	90	1¼"	28.3	145	227	202	254	126	24	G¾"	32	M5	50
ACP6059TNV1	90	1½"	28.3	160	243	211	264	126	24	G¾"	32	M5	64
ACP8059TNV1	90	2"	28.3	190	258	226	288	126	24	G¾"	32	M5	64

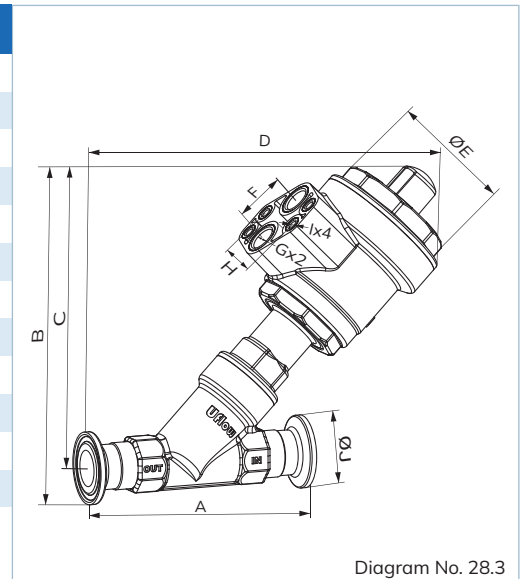

Technical Data

Pipe (Inch)	Body Material	Orifice (mm)	Seal & 'O' Ring Material	Flow Factor Kv m³ / hr
½"	CF8 / CF8M	15	PTFE / PEEK / VITON	6
¾"	CF8 / CF8M	20	PTFE / PEEK / VITON	10.9
1"	CF8 / CF8M	25	PTFE / PEEK / VITON	21
1¼"	CF8 / CF8M	32	PTFE / PEEK / VITON	35
1½"	CF8 / CF8M	40	PTFE / PEEK / VITON	49
2"	CF8 / CF8M	50	PTFE / PEEK / VITON	68
2½"	CF8 / CF8M	65	PTFE / PEEK / VITON	120

Pressure Chart

Pipe (Inch)	Actuator	NC				NO				Double Acting			
		Above Plug		Below Plug		Above Plug		Below Plug		Above Plug		Below Plug	
		Pilot Pressure	Line Pressure	Pilot Pressure	Line Pressure	Pilot Pressure	Line Pressure	Pilot Pressure	Line Pressure	Pilot Pressure	Line Pressure	Pilot Pressure	Line Pressure
½"	40	4.5	16	-	-	4.5	16	-	-	4.5	20	4	16
		4.5	20	-	-	6	18	-	-	3	16	4.5	20
¾"	40	5.5	16	-	-	-	-	-	-	3.8	16	4.5	16
		6.2	19	-	-	-	-	-	-	5	20	5	20
		-	-	-	-	-	-	-	-	-	-	-	-
¾"	50	4.5	16	-	-	4	13	6.5	12	3.5	16	5	16
		5.5	20	-	-	-	-	-	-	4.5	20	5.5	20
		-	-	-	-	-	-	-	-	-	-	-	-
1"	63	5.5	16	-	-	4.5	15	7	8	4.5	16	4.5	16
		4.5	20	-	-	-	-	-	-	4.5	20	5	20
		-	-	-	-	-	-	-	-	-	-	-	-
1¼"	63	6.5	16	-	-	4.5	13	-	-	3.5	16	6	16
		6.5	20	-	-	-	-	-	-	6	20	6.5	20
1½"	63	4.5	12	-	-	-	-	7	9	5	10	-	-
		-	-	-	-	4.5	8	-	-	7	16	-	-
		-	-	-	-	-	-	-	-	-	-	-	-
1½"	90	4.5	16	-	-	4.5	10	7	9	4.7	16	4	16
		5	20	-	-	-	-	-	-	5	20	5	20
		-	-	-	-	-	-	-	-	-	-	-	-
2"	90	5.8	16	-	-	5	16	7	10	5.5	16	7	18
		7	19	-	-	-	-	-	-	6.2	20	-	-
		-	-	-	-	-	-	-	-	-	-	-	-
2½"	90	7	10.5	-	-	-	-	-	-	-	-	-	-
		4.5	7	-	-	-	-	-	-	-	-	-	-

Pressure Above Plug

Pressure Below Plug

	A	B
Normally Open	Pilot Inlet	Exhaust
Normally Close	Exhaust	Pilot Inlet

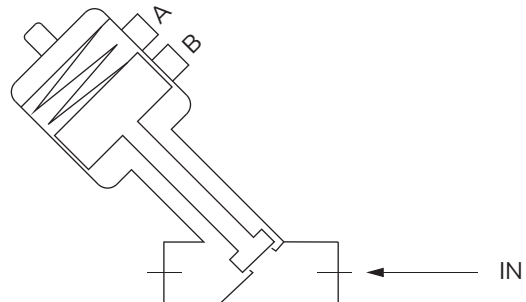
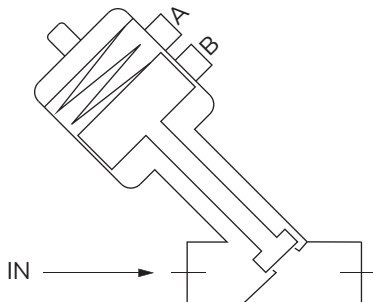

ANGLE SEAT VALVE WITH PLASTIC ACTUATOR OPERATED MODEL IDENTIFICATION CHART



PRODUCT TYPE	SEAL MATERIAL	PORT SIZE	PRESSURE RANGE	ACTUATOR SIZE	PORT CONNECTION	VALVE POSITION	CONFIGURATION	VERSION
A	P	2	02	4	B	N	BLANK	V0
	K	3	14	5	N	Z	C1	V1
		4	03	6	F	D	C2	V2
		5	05	8	T	C	C3	V3
		6	11	9	P	O
		8	04		S	B	C9	V9
		9	21		G	R	CA	VA
			38			L	CB	VB
			13			I		
			32					

BODY MATERIAL	
C	CF8
M	CF8M
3	CF3M
E	CF8 PED
H	CF8M PED
T	CF3 PED
U	CF3M PED

ACP2035BZV1
 1/2" ANGLE SEAT VALVE PLASTIC OPERATOR CF8-PTFE-0 TO 7 Bar-50mm NAMUR-BSP-NO ABOVE-VERSION 1

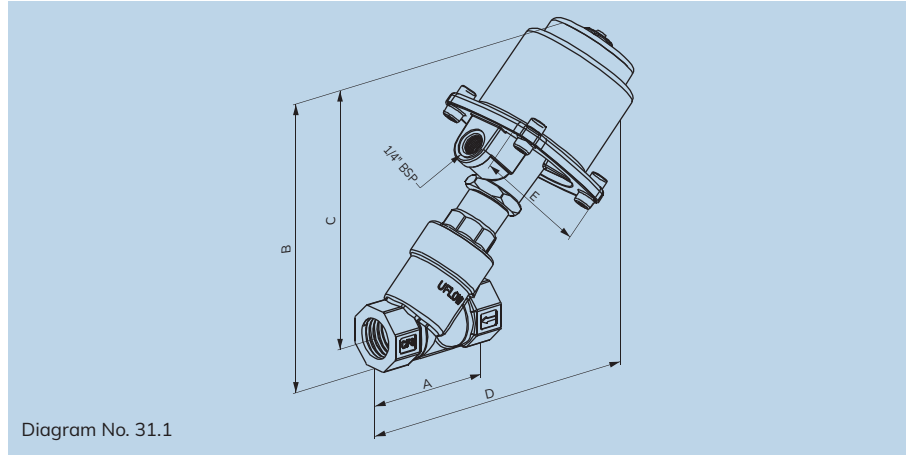
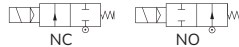

Diagram No. 31.1



Specifications

Port :	½", ¾", 1", 1¼", 1½" & 2" (Available in BSP/NPT)
End Connection :	Screwed / Flange / Tri-Clamp / Socket Weld
Body Material :	SS ASTM A351 Grade CF8 / CF8M / CF3M
Seal :	PTFE / VITON
Circumstance Temp :	-10°C to 70°C
Media Temp :	-10°C to 180°C
Media :	Steam, Air, Water, Chemical, Gases, Oil, Diesel, Hot Water
Other Specification Data:	Available on request - Adjust Stroke Limiter - Position Sensor

Dimension - NC (All dimensions in mm)

All Dimensions are approx.

Model No.	Port Size	Diagram No.	A	B	C	D	E
YCP205BNV1	½"	31.1	65	155	142	165	90
YCP305BNV1	¾"	31.1	77	161	145	171	90
YCP405BNV1	1"	31.1	89	182	162	190	90
YCP505BNV1	1¼"	31.1	110	198	174	209	90
YCP605BNV1	1½"	31.1	124	202	175	210	90
YCP803BNV1	2"	31.1	150	225	191	234	90

Section View

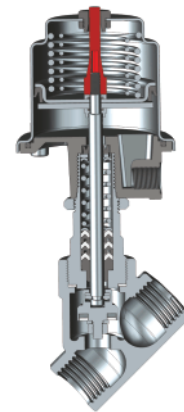

Actuator Type

Cover :	SS304
Plate :	Aluminium Die-Cast
Working Pressure :	3.5 to 7 bar air (Not Recommended actuator for pneumatic pressure above 7 bar)
Seal Material :	NBR / VITON
Life :	More than ten million cycle
Other Technical Data :	Available on Request

Technical Data

Model No.	Body Material	Pipe (Inch)	Orifice (mm)	Min. Operating Pressure Kg/cm ²	Max. Operating Pressure Kg/cm ²	Seal & 'O' Ring Material	Flow Factor Kv m ³ / hr
YCP205BNV1	CF8 / CF8M	½"	15	0	16	PTFE / VITON	6
YCP305BNV1	CF8 / CF8M	¾"	20	0	16	PTFE / VITON	10.9
YCP405BNV1	CF8 / CF8M	1"	25	0	16	PTFE / VITON	21
YCP505BNV1	CF8 / CF8M	1¼"	32	0	16	PTFE / VITON	35
YCP605BNV1	CF8 / CF8M	1½"	40	0	16	PTFE / VITON	49
YCP803BNV1	CF8 / CF8M	2"	50	0	07	PTFE / VITON	68

ANGLE SEAT VALVE WITH STEEL ACTUATOR OPERATED MODEL IDENTIFICATION CHART

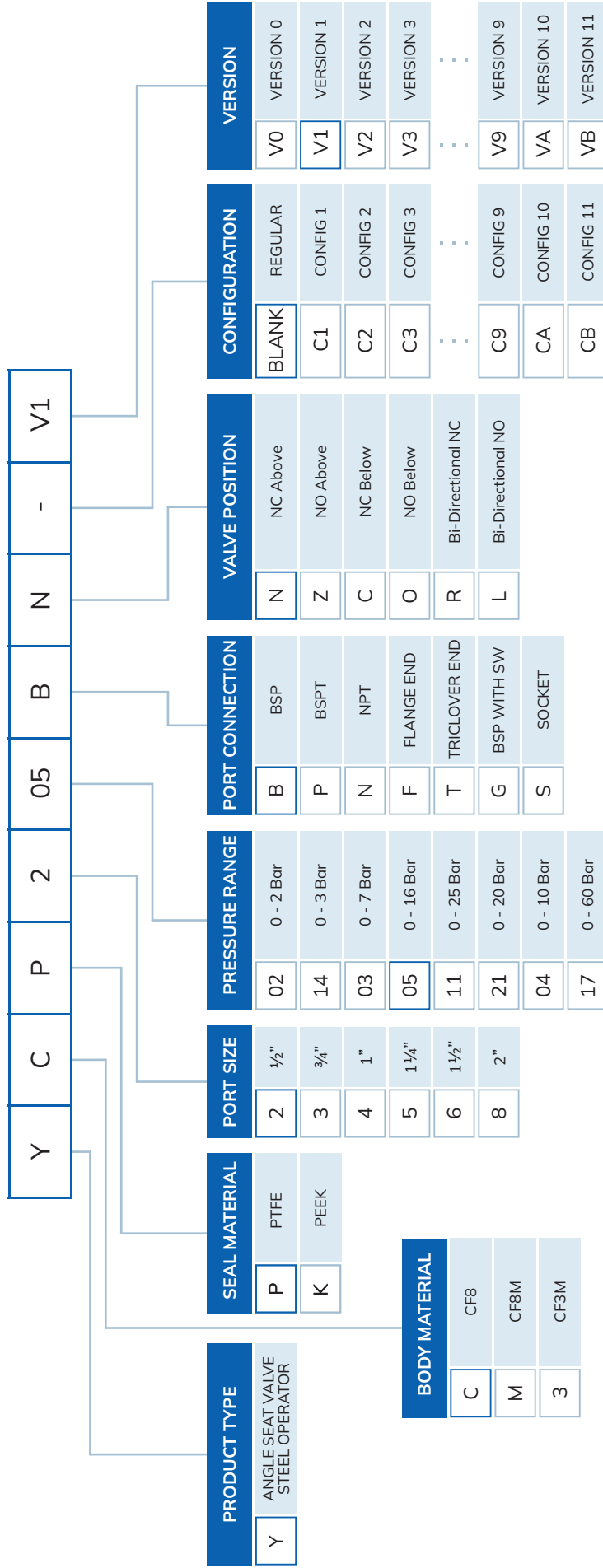

YCP205BNV1
 1/2" ANGLE SEAT VALVE STEEL OPERATOR CF8-PTFE-0 TO 16 Bar-BSP-NC ABOVE-VERSION 1

Note: The above chart is for identification purposes only, and it may not be possible to make all combinations for the above chart.



Specifications

Port :	Refer below technical data sheet (Available BSP / NPT)
End Connection :	Screw End
Body Material :	SS ASTM A351 Grade CF8
Seal :	PTFE / VITON
Circumstance Temp :	-10°C to 70°C
Media Temp :	-10°C to 180°C
Media :	Steam, Air, Water, Chemical, Gases, Oil, Diesel, Hot Water
Leakage :	As per ANSI B16.104 - 1976 Teflon seating class IV. For other soft seating class VI Drop Tight/Bubble Tight.
Stem Packing :	Self adjusting, Spring loaded Teflon packing.
Air Quality :	Lubricated /Non-lubricated.

Actuator (Spring Return) Type

Cover :	CF8
Plate :	CF8
Working Pressure :	4.5 to 7 bar air (Not Recommended actuator for pneumatic pressure above 7 bar)
Seal Material :	NBR / VITON
Life :	1 million cycle
Other Technical Data :	Available on Request

Mixing

Valves can be used for introducing two different fluids (mixing) through two different ports to common port 'AB'.

Diverting

One fluid coming through port 'AB' can be diverted to 'A' port or 'B' port.

Operation

In normal condition, 'A' port is closed and 'AB' port is connected to 'B' or 'B' port is connected to 'AB' port. On receiving pilot pressure, 'A' port is connected to 'AB' or 'AB' port is connected to 'A' closing port B.

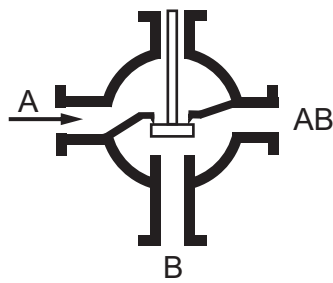
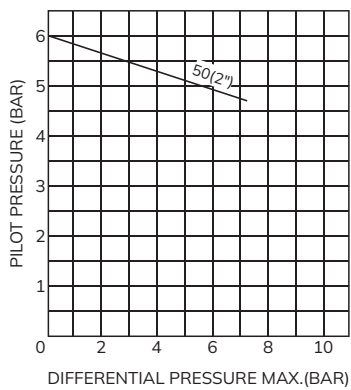

Pressure at Port 'A', AB Connected 'B' 'A' is Close.

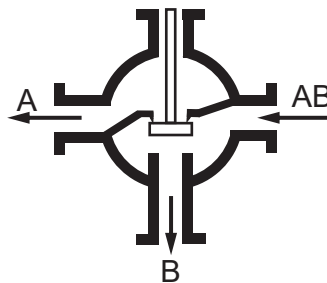

Diverting - Pressure at 'AB' Connected to 'B' 'A' Port is Close.

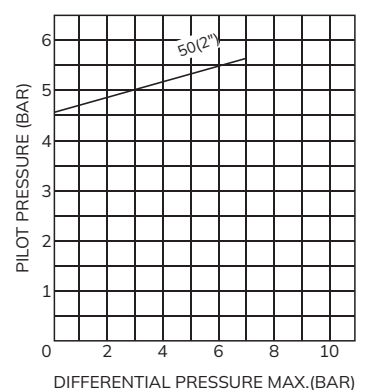

Technical Data

Model No.	Body Material	Pipe (Inch)	Orifice (mm)	Min. Operating Pressure Kg/cm ²	Max. Operating Pressure Kg/cm ²	Seal & 'O' Ring Material	Flow Factor Kv m ³ / hr
TCP803EBZV0	CF8	2"	45	0	7	PTFE	35

Dimension (All dimensions in mm)

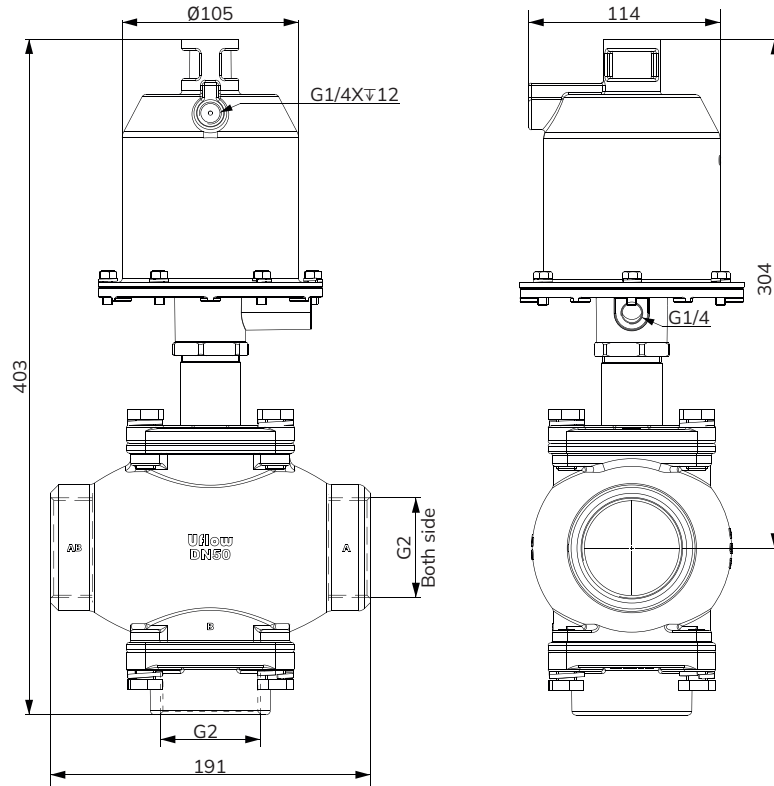

* All dimensions are approx

3 WAY CONTROL VALVE WITH STEEL ACTUATOR OPERATED MODEL IDENTIFICATION CHART

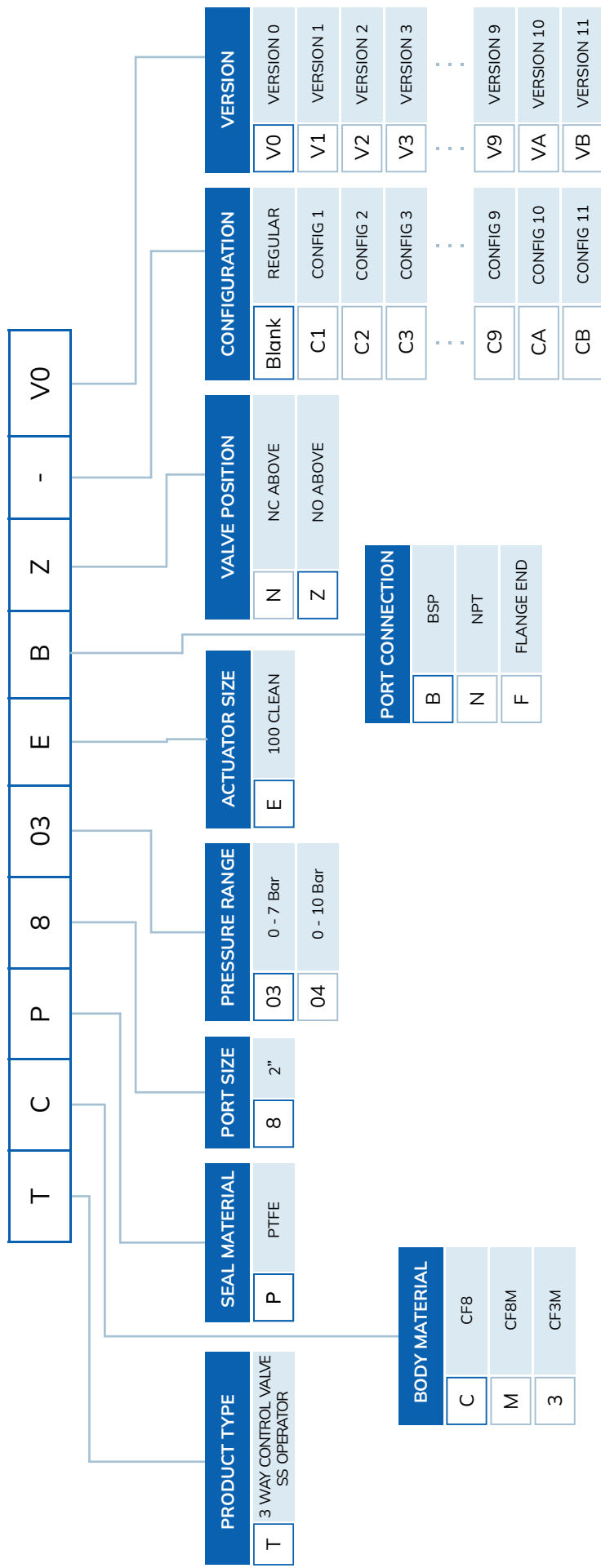

TCP803EBZV0
2" 3 WAY CONTROL VALVE CF8-PTFE-0 TO 7 Bar-100 CLEAN-BSP-NO ABOVE

Note: The above chart is for identification purposes only, and it may not be possible to make all combinations for the above chart.



PNEUMATIC ACTUATOR SERIES

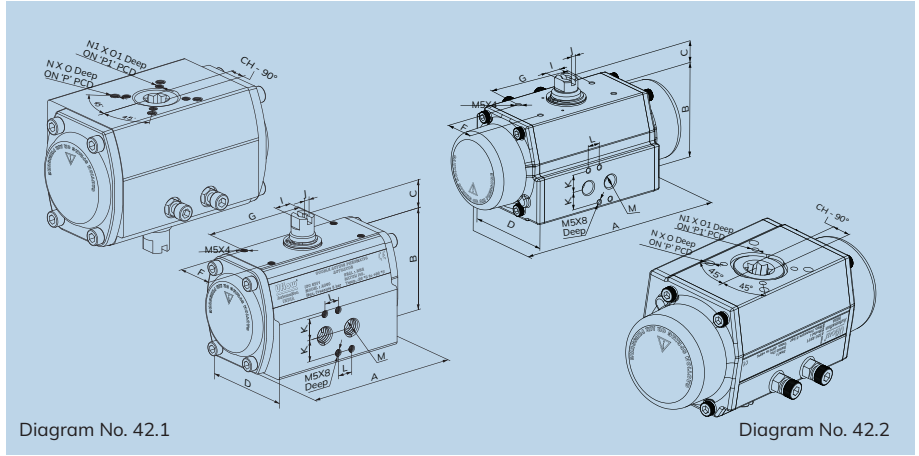

Features

Uflow has successfully developed Compact, Patented Aluminium Free Rack & Pinion Pneumatic Rotary Actuator and Consuming Low Volume of Air.

- ✓ Wear proof aluminium free Rack & Pinion design.
- ✓ Low air consumption with maximum torque due to compact design.
- ✓ Providing a hard-anodized body for high corrosion resistance.
- ✓ Smooth travelling stroke for extending the life of ball valve seat.
- ✓ Finer teeth module for smoother operation, and jerk-free sliding.
- ✓ Maintenance free design.
- ✓ Aluminium Extruded, Hard Anodized Body.
- ✓ Design Standard : ISO 5211.
- ✓ Approved as per ATEX.

Section View



Temperature Range

NBR	-20°C to +80°C
Viton	-20°C to +125°C
Flourosilicone	-60°C to +110°C

End Stroke (0° - 90°)

+5° Over travelling possible for opening
-5° Under travelling can be adjusted

Working Pressure

Maximum working pressure 8 bar

Air Consumption Comparison With Other Reputed Brand

Model	Piston Inward Stroke ml / bar	Piston Outward Stroke ml / bar
(Uflow)AD50	128	137
Other Brand Y	260	110
Other Brand X	200	180

Technical Data (All dimensions in mm)

All Dimensions are approx.

Model No. Double / Single	Diagram No.	A Double / Single	B	C	D	F	G	I	J	K	L	M	N	O	P	N1	O1	P1	CH 90°	ISO FLANGE
AD32ANBV2 / AS32ANB02V2	42.1 / 42.2	92 / 115	48	20	54	30	50	10	4	16	12	1/8"	M5	09	36	-	-	-	09	F03
AD40ANBV2 / AS40ANB02V2	42.1 / 42.2	124/160	66	20	64	30	80	13	4	16	12	1/4"	M5	12	50	M4	10	36	11	F03/F05
AD50ANBV2 / AS50ANB02V2	42.1 / 42.2	131/162	77	20	72	30	80	13	4	16	12	1/4"	M6	12	50	M5	10	36	11	F03/F05
AD63ANBV2 / AS63ANB02V2	42.1 / 42.2	147/203	87	20	86	30	80	15	4	16	12	1/4"	M8	12	70	M6	10	50	14	F05/F07
AD80ANBV2 / AS80ANB201V2	42.1 / 42.2	170/233	103	20	98	30	80	18	4	16	12	1/4"	M8	12	70	M6	10	50	17	F05/F07
AD90ANBV2 / AS90ANB6UV2	42.1 / 42.2	198/277	115	20	110	30	80	22	4	16	12	1/4"	M8	12	70	-	-	-	17	F07
AD100ANBV2 / AS100ANB6UV2	42.1 / 42.2	217/302	129	20	126	30	80	26	4	16	12	1/4"	M10	15	102	M8	14	70	22	F07/F10
AD110ANBV2 / AS110ANB6UV2	42.1 / 42.2	231/332	136	20	131	30	80	30	4	16	12	1/4"	M10	15	102	M8	14	70	22	F07/F10
AD125ANBV2 / AS125ANB6UV2	42.1 / 42.2	263/355	161	20	150	30	80	30	4	16	12	1/4"	M12	20	125	M10	14	102	22	F10/F12
AD150ANBV2 / AS150ANB6UV2	42.1 / 42.2	296	188	20	175	30	80	35	4	16	12	1/4"	M12	20	125	M10	14	102	27	F10/F12
AD175ANBV2 / AS175ANB6UV2	42.1 / 42.2	500	212	20.5	98	30	80	41	4	16	12	1/4"	M12	20	125	M10	20	102	27	F10/F12
AD200ANBV2 / AS200ANB7UV2	42.1 / 42.2	552	255	30	110	30	130	41	4	16	12	1/4"	M16	24	140	M10	15	102	36	F10/F14
AD250ANBV2 / AS250ANB7UV2	42.1 / 42.2	723	255	30	126	30	130	41	4	16	12	1/4"	M16	24	140	-	-	-	46	F14
AD300ANBV2 / AS300ANB7UV2	42.1 / 42.2	755	360	30	131	30	130	41	4	22.5	20	1/2"	M20	30	165	-	-	-	46	F16
AD350ANBV2 / AS350ANB7UV2	42.1 / 42.2	865	360	30	150	30	130	41	4	22.5	20	1/2"	M20	30	165	-	-	-	55	F16

Torque Chart (Double Acting)

TORQUE Nm (10Nm = 1 Kgm)

Model No.	Diagram No.	2 Bar	3 Bar	4 Bar	5 Bar	6 Bar	7 Bar	8 Bar	Piston Inward Stroke, ml/bar	Piston Outward Stroke, ml/bar
AD32ANBV2	42.1	3	5	6	8	9	11	12	36	40
AD40ANBV2	42.1	7	10	14	17	21	24	28	83	104
AD50ANBV2	42.1	11	16	22	27	32.5	38	43	128	137
AD63ANBV2	42.1	20	30	40	50	60	70	80	210	280
AD80ANBV2	42.1	35	52	69	87	103	121	138	360	450
AD90ANBV2	42.1	51	76	102	127	153	178	204	522	768
AD100ANBV2	42.1	73	110	146	183	220	256	293	780	1040
AD110ANBV2	42.1	90	135	180	225	270	315	360	966	1325
AD125ANBV2	42.1	127	190	254	318	381	446	508	2800	1810
AD150ANBV2	42.1	210	316	421	526	631	737	842	5390	3150
AD175ANBV2	42.1	300	450	600	750	900	1050	1200	7525	4720
AD200ANBV2	42.1	456	684	912	1140	1368	1596	1824	11980	7780
AD250ANBV2	42.1	741	1111	1482	1852	2223	2593	2964	14870	12145
AD300ANBV2	42.1	1125	1688	2251	2813	3376	3939	4502	37175	19630
AD350ANBV2	42.1	1540	2310	3080	3850	4620	5390	6160	40535	26430

Torque Chart (Single Acting)

TORQUE Nm (10Nm = 1 Kgm)

Size	Model No.	Spring Set	Spring Torque		3 Bar		4 Bar		5 Bar		6 Bar		Piston Outward Stroke, ml/bar
			0° (Min)	90° (Max)	90° (Min)	0° (Max)	90° (Min)	0° (Max)	90° (Min)	0° (Max)	90° (Min)	0° (Max)	
32	AS32ANB21V2	21	2	3	2	3	3	4	5	6	6	7	40
	AS32ANB12V2	12	3	5	-	-	1	3	3	5	4	6	
	AS32ANB22V2	22	4	6	-	-	1	2	2	4	3	5	
40	AS40ANB02V2	02	5	8	3	5	6	9	10	12	13	16	104
	AS40ANB21V2	21	5	8	2	5	6	8	9	12	12	15	
	AS40ANB12V2	12	6	10	1	4	4	7	7	11	11	14	
	AS40ANB22V2	22	8	12	-	-	2	6	5	9	9	13	
50	AS50ANB02V2	02	6	13	3	10	9	16	14	21	20	27	137
	AS50ANB21V2	21	8	14	2	8	8	14	13	19	19	25	
	AS50ANB12V2	12	9	16	-	-	6	13	11	18	17	24	
	AS50ANB22V2	22	12	18	-	-	4	10	9	15	15	21	
63	AS63ANB02V2	02	11	22	8	19	18	29	28	39	38	49	280
	AS63ANB21V2	21	15	24	6	15	16	25	26	35	36	45	
	AS63ANB12V2	12	16	29	1	14	11	24	21	34	31	44	
	AS63ANB22V2	22	21	35	-	-	5	19	15	29	25	39	
80	AS80ANB201V2	201	13	23	29	39	46	56	63	73	80	90	450
	AS80ANB211V2	211	19	34	18	33	35	50	52	67	69	84	
	AS80ANB121V2	121	23	40	12	29	29	46	46	63	63	80	
	AS80ANB112V2	112	23	43	9	29	26	46	43	63	60	80	
	AS80ANB212V2	212	26	47	5	26	22	43	39	60	56	77	
	AS80ANB222V2	222	36	61	-	-	8	33	25	50	42	67	

Torque Chart (Single Acting)

TORQUE Nm (10Nm = 1 KgM)

Size	Model No.	Spring Set	Spring Torque		3 Bar		4 Bar		5 Bar		6 Bar		Piston Outward Stroke, ml/bar
			0° (Min)	90° (Max)	90° (Min)	0° (Max)	90° (Min)	0° (Max)	90° (Min)	0° (Max)	90° (Min)	0° (Max)	
90	AS90ANB201V2	201	27	41	35	49	61	75	86	100	112	126	768
	AS90ANB211V2	211	34	54	22	42	48	68	73	93	99	119	
	AS90ANB121V2	121	36	58	18	40	44	66	69	91	95	117	
	AS90ANB112V2	112	43	68	8	33	34	59	59	84	85	110	
	AS90ANB212V2	212	49	77	-	27	25	53	50	78	76	104	
	AS90ANB222V2	222	57	90	-	19	12	45	37	70	63	96	
100	AS100ANB6UV2	6U	40	59	51	70	87	106	124	143	161	180	1040
	AS100ANB7U2V2	7U2	51	77	33	59	69	95	106	132	143	169	
	AS100ANB09V2	9	53	81	29	57	65	93	102	130	139	167	
	AS100ANB10UV2	10U	61	96	14	49	50	85	87	122	124	159	
	AS100ANB12V2	12	71	109	-	-	37	75	74	112	111	149	
	AS100ANB14V2	14	83	127	-	-	19	63	56	100	93	137	
110	AS110ANB6UV2	6U	48	75	60	87	105	132	150	177	195	222	1325
	AS110ANB7U2V2	7U2	60	94	41	75	86	120	131	165	176	210	
	AS110ANB09V2	9	66	101	34	69	79	114	124	159	169	204	
	AS110ANB10UV2	10U	78	120	15	57	60	102	105	147	150	192	
	AS110ANB12V2	12	88	135	-	47	45	92	90	137	135	182	
	AS110ANB14V2	14	102	157	-	33	23	78	68	123	113	168	
125	AS125ANB6UV2	6U	62	99	91	128	155	192	219	256	282	319	1810
	AS125ANB8UV2	8U	81	129	61	109	125	173	188	236	252	300	
	AS125ANB09V2	9	86	137	53	104	117	168	181	231	244	295	
	AS125ANB11V2	11	105	167	23	85	87	149	151	212	214	276	
	AS125ANB12UV2	12U	119	190	-	-	64	135	128	198	191	262	
	AS125ANB13UV2	13U	129	205	-	-	49	125	113	189	176	252	
150	AS150ANB6UV2	6U	105	170	146	211	251	316	356	421	461	526	3150
	AS150ANB8UV2	8U	137	222	94	179	199	284	304	389	409	494	
	AS150ANB09V2	9	144	234	82	172	187	277	294	382	391	487	
	AS150ANB11V2	11	176	285	30	140	135	245	240	350	345	455	
	AS150ANB12UV2	12U	201	326	-	115	95	220	200	325	305	430	
	AS150ANB13UV2	13U	217	352	-	99	69	204	174	309	279	414	
175	AS175ANB6UV2	6U	145	238	212	305	362	455	512	605	662	755	4720
	AS175ANB8UV2	8U	190	311	139	260	289	410	439	560	589	710	
	AS175ANB09V2	9	201	330	120	249	270	399	420	549	570	699	
	AS175ANB11V2	11	245	403	47	205	197	355	347	505	497	655	
	AS175ANB12UV2	12U	279	458	-	171	142	321	292	471	442	621	
	AS175ANB13UV2	13U	301	494	-	149	106	299	256	449	406	599	

Torque Chart (Single Acting)

TORQUE Nm (10Nm = 1 Kg)

Size	Model No.	Spring Set	Spring Torque		3 Bar		4 Bar		5 Bar		6 Bar		Piston Outward Stroke, ml/bar
			0° (Min)	90° (Max)	90° (Min)	0° (Max)	90° (Min)	0° (Max)	90° (Min)	0° (Max)	90° (Min)	0° (Max)	
200	AS200ANB7UV2	7U	235	425	259	449	487	677	715	905	943	1133	7780
	AS200ANB10V2	10	315	567	117	369	345	597	573	825	801	1053	
	AS200ANB14V2	14	440	794	-	244	118	472	346	700	574	928	
250	AS250ANB7UV2	7U	382	688	423	729	794	1100	1164	1470	1535	1841	12145
	AS250ANB10V2	10	509	919	192	602	563	973	933	1343	1304	1714	
	AS250ANB14V2	14	713	1287	-	398	195	769	565	1139	936	1510	
300	AS300ANB7UV2	7U	692	1055	633	996	1196	1559	1758	2121	2321	2684	19630
	AS300ANB10V2	10	925	1407	281	763	844	1326	1406	1888	1969	2451	
	AS300ANB14V2	14	1295	1970	-	393	281	956	843	1518	1406	2081	
350	AS350ANB7UV2	7U	947	1443	867	1363	1637	2133	2407	2903	3177	3673	26430
	AS350ANB10V2	10	1264	1925	385	1046	1155	1816	1925	2586	2695	3356	
	AS350ANB14V2	14	1769	2695	-	541	385	1311	1155	2081	1925	2851	

DOUBLE ACTING ROTARY ACTUATOR MODEL IDENTIFICATION CHART

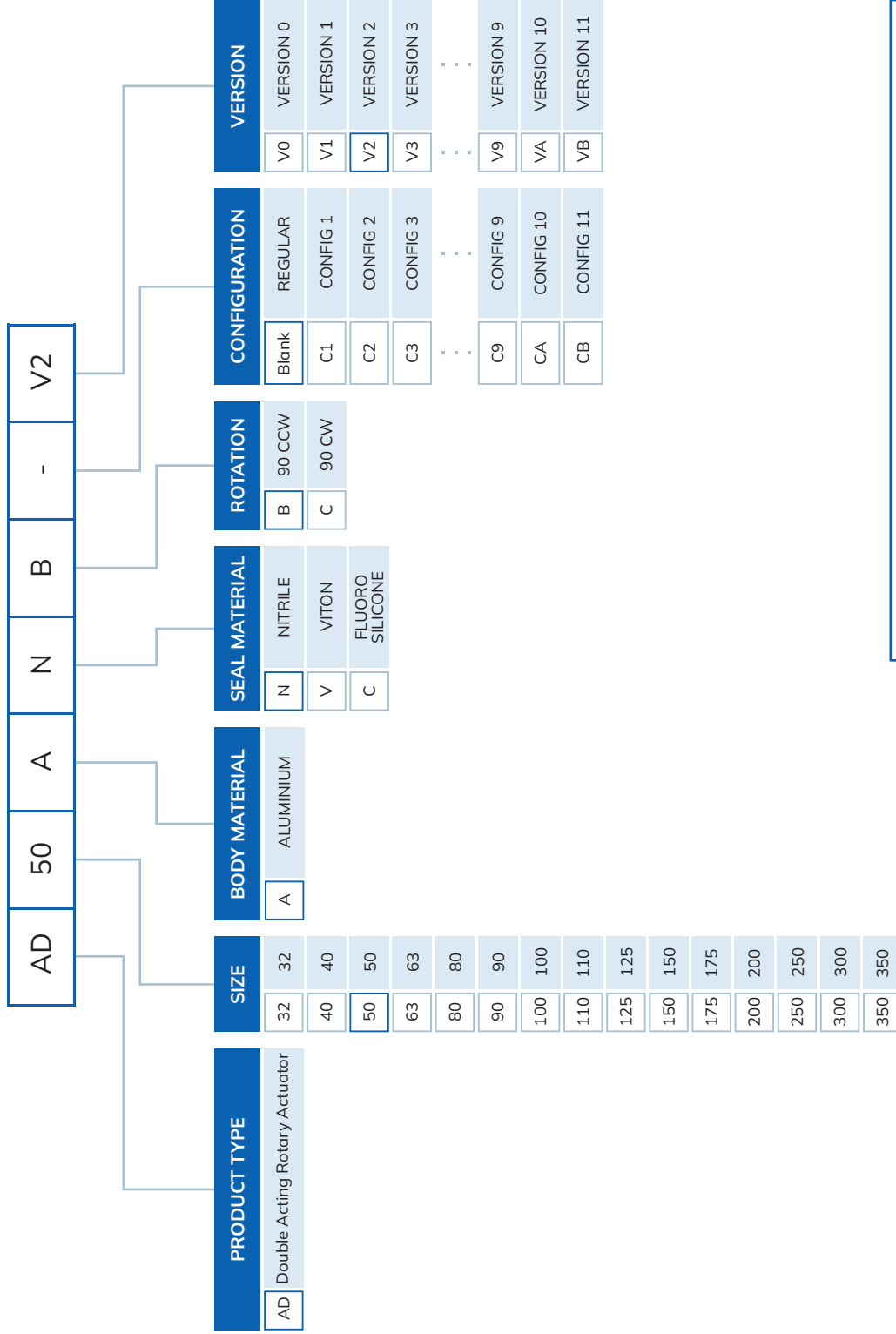

AD50ANBV2
DOUBLE ACTING ACTUATOR SIZE 50 ALUMINIUM-NITRILE-90 CCW-VERSION 2

SINGLE ACTING ROTARY ACTUATOR MODEL IDENTIFICATION CHART

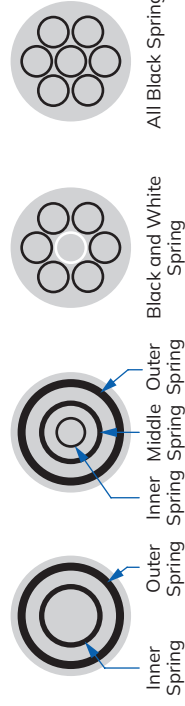
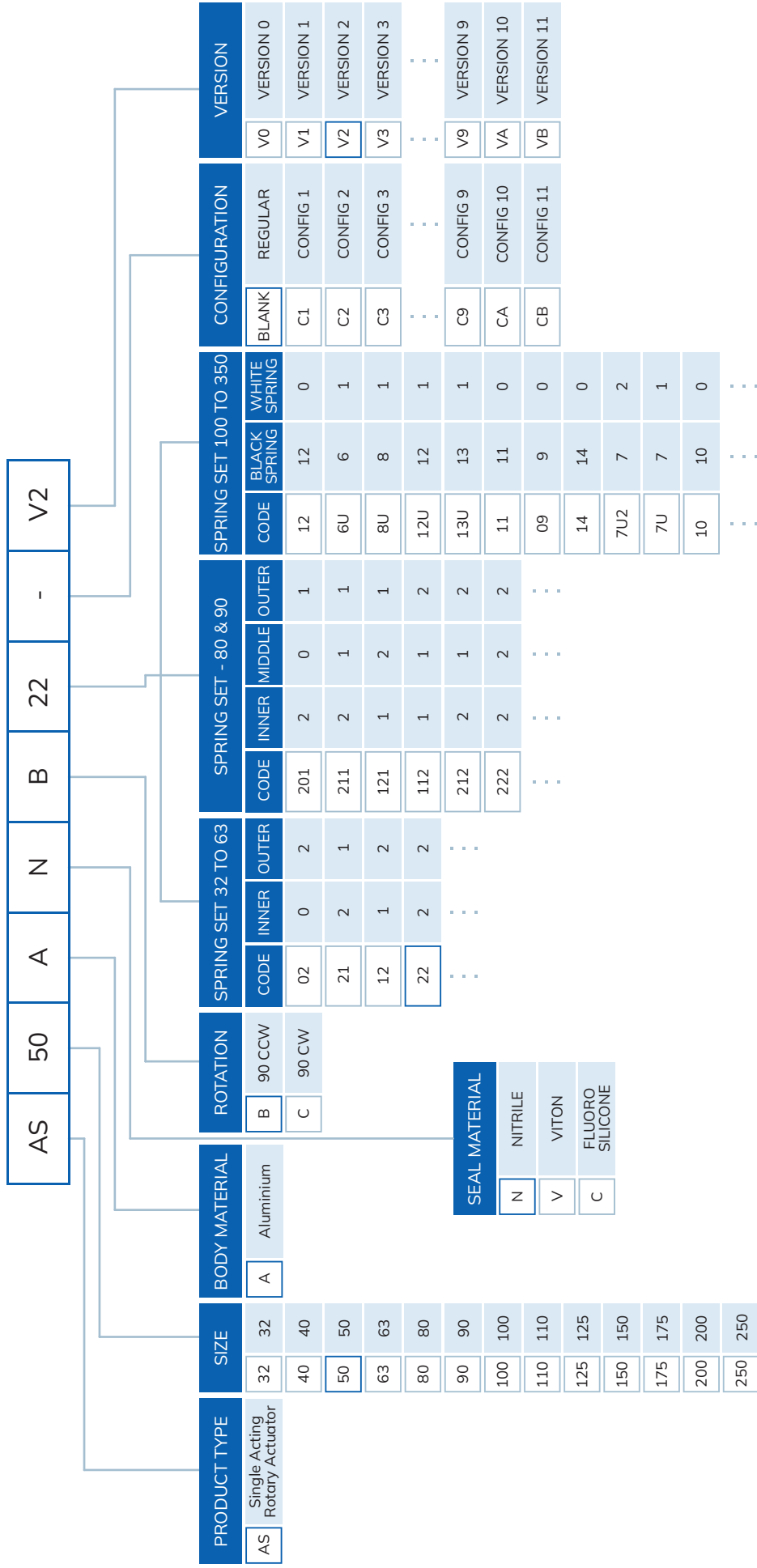

(CW) : Clockwise, fail safe open
(CCW) : Counter clockwise, fail safe close

AS50ANB22V2
SINGLE ACTING ACTUATOR SIZE 50 ALUMINIUM-NITRILE-90 CCW-WITH SPRING SET NO 22-VERSION 2



**BALL VALVE
SERIES**

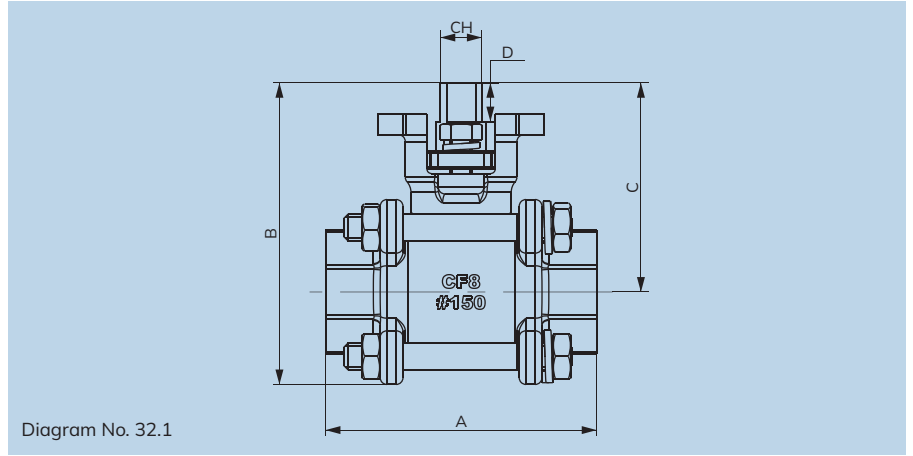

Specifications

Size :	DN15 - DN100
End Connection :	Screwed end (BSP / NPT), Socket Weld
Face to Face :	MFG. Standard
Design Standard :	ASME B16.11, ASME B16.34, API 598, BS EN ISO 17292, ISO 5211
Pressure Class :	150#, 300#
Body Material :	CF8 / CF8M / WCB / CF3M
Pipe End Material :	CF8 / CF8M / WCB / CF3M
Ball Material :	CF8 / CF8M
Body Seal Material :	PTFE / RPTFE / CFT / GFT / PEEK
Seat Ring Material :	PTFE / RPTFE / CFT / GFT / PEEK
Fastener Material :	SS304 / SS316
Stem Seal Material :	PTFE / RPTFE / CFT / GFT / PEEK
Stem Material :	SS304 / SS316 / SS410
Gland Bush Material :	SS304 / SS316 / SS410
Gland Material :	SS304 / SS316 / SS410

Features

- 3PC design twinseal ball valve.
- Full port ball valve.
- Blow out proof stem.
- Floating ball design.
- Hand Lever / Gear / Actuator Operated.
- Face to Face:- MFG standard.
- End Connection:- Screwed / Socket weld (ASME B16.11).
- Balls are precision machined and mirror finished for bubble-tight shut off with less operating torque.
- ISO 5211 top mounting pad available for easy Uflow make actuator mounting.

Section View

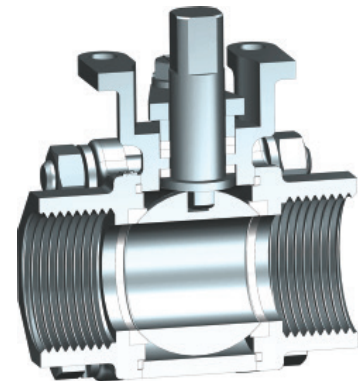

All dimensions are approx.

Dimension (All dimensions in mm)

Model No.	Diagram No.	Pipe (Inch)	A	B	CH	D	C	ISO 5211
BCPC2ABFBV0	32.1	½"	59.50	66	9.1	8.5	46	F03
BCPC3ABFBV0	32.1	¾"	57	71	9.1	9	50	F03
BCPC4ABFBV0	32.1	1"	75.70	90	11	13.5	61.5	F05
BCPC5ABFBV0	32.1	1¼"	85	102.7	11	13	70	F05
BCPC6ABFBV0	32.1	1½"	93.60	110	11	13	73.5	F05
BCPC8ABFBV0	32.1	2"	109	139.6	14	15.5	94	F05
BCPC9ABFBV0	32.1	2½"	139	173	14	15	108.5	F07
BCPCAABFBV0	32.1	3"	166	195	17	16.5	119.5	F07
BCPCBABFBV0	32.1	4"	193	236	22	23	144	F07

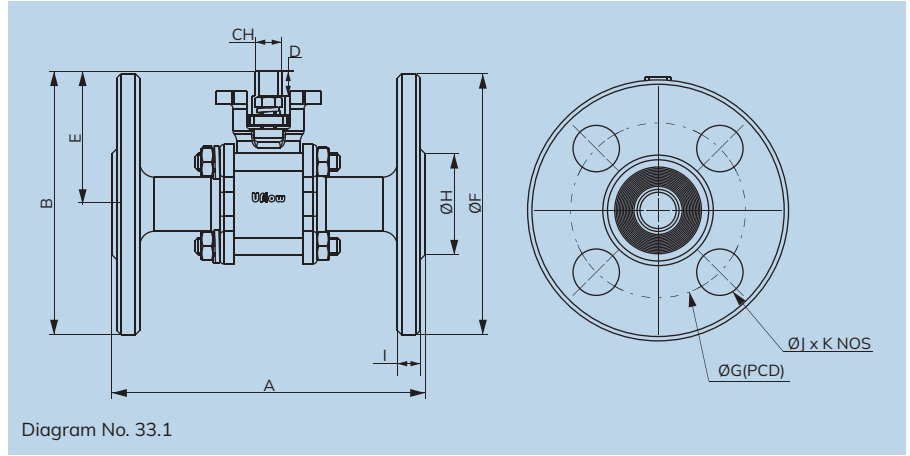

Specifications

Size :	DN15 - DN100
End Connection :	Flange end
Face to Face :	ASME B 16.10 (Flange end)
Pressure Class :	150#, 300#
Design Standard :	ASME B16.10, ASME B16.25, ASME B16.34, ASME B16.5, API 598, BS EN ISO 17292, ISO 5211
Body Material :	CF8 / CF8M / WCB / CF3M
Tail Piece Material :	CF8 / CF8M / WCB / CF3M
Ball Material :	CF8 / CF8M
Body Seal Material :	PTFE / RPTFE / CFT / GFT / PEEK
Seat Ring Material :	PTFE / RPTFE / CFT / GFT / PEEK
Fastener Material :	SS304 / SS316
Stem Seal Material :	PTFE / RPTFE / CFT / GFT / PEEK
Stem Material :	SS304 / SS316 / SS410
Gland Bush Material :	SS304 / SS316 / SS410
Gland Material :	SS304 / SS316 / SS410

Features

- 3PC design twinseal ball valve.
- Full port ball valve.
- Blow out proof stem.
- Floating ball design.
- Hand Lever / Gear / Actuator Operated.
- Face to Face:- ASME B16.10.
- End Connection:- Flanged (ASME B16.5), Butt-weld (ASME B16.25)
- Balls are precision machined and mirror finished for bubble-tight shut off with less operating torque.
- ISO 5211 top mounting pad available for easy Uflow make actuator mounting.

Section View

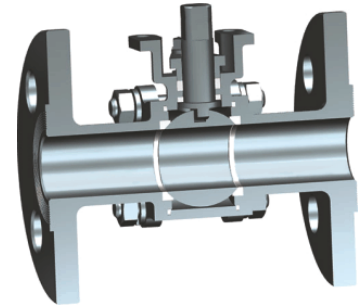

Dimension (All dimensions in mm)

All dimensions are approx.

Model No.	Diagram No.	Pipe (Inch)	A	B	CH	D	E	F	G	H	I	J	K	ISO 5211
BCPC2AFFBV0	33.1	½"	108	91	9.1	8.5	46	90	60.5	35	8	16	4	F03
BCPC3AFFBV0	33.1	¾"	117	100	9.1	9	50	100	70	44.5	9	16	4	F03
BCPC4AFFBV0	33.1	1"	127	117	11	13.5	61.5	110	79.5	48	9.6	16	4	F05
BCPC5AFFBV0	33.1	1¼"	140	127	11	13	70	115	89	63.5	11.2	16	4	F05
BCPC6AFFBV0	33.1	1½"	165	136	11	13	73.5	125	98.5	73	12.5	16	4	F05
BCPC8AFFBV0	33.1	2"	178	169	14	15.5	94	150	121	92	14.5	19	4	F05
BCPC9AFFBV0	33.1	2½"	190	198.5	14	15	108.5	180	139.5	105	16	19.5	4	F07
BCPCAFFBV0	33.1	3"	203	214.5	17	16.5	119.5	190	152.5	127	17.5	19.5	4	F07
BCPCBAFFBV0	33.1	4"	229	259	22	23	144	230	190.5	157	22.5	19	8	F07

BALL VALVE MODEL IDENTIFICATION CHART

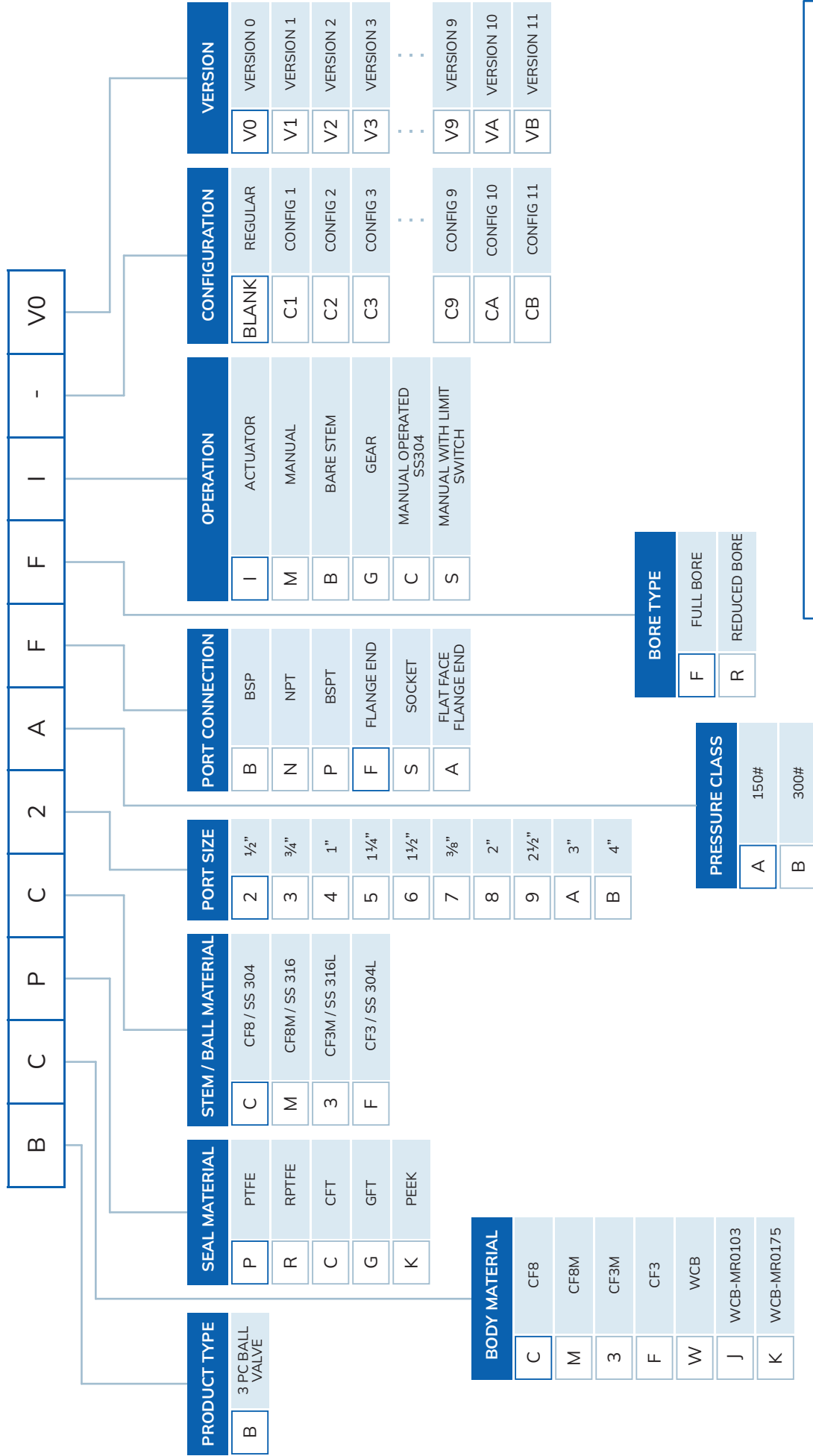

BCPC2AFFI0

1/2" 3 PC BALL VALVE CF8-PTFE- SS 304 - 150#- FLANGE END-FULL BORE-ACTUATORE



**BUTTERFLY VALVE
SERIES**

Specifications

End Connection :	Wafer - API 609 (CAT - A)
Size :	DN40 - DN300
Suitable :	ASME B16.5 150#
Pressure Range :	PN06, PN10, PN16
Leakage Class :	100% Tightness at fully differential pressure
Standard :	API 609, BS 5155, ISO 5211, API 598, ASME B16.5
Body Material :	Cast Iron(CI), SGI, WCB, CF8, CF8M
Disc Material :	SGI, CF8, CF8M, WCB
Stem Material :	SS410, SS304, SS316
Body Liner / Seat Material :	NBR, EPDM, VITON
Shaft Bearing Material :	PTFE

Features

- ☑ Bi-directional zero leakage butterfly valve.
- ☑ ISO Pad for mounting, Gear Operator / Actuator
- ☑ Extremely small play between the stem and disc due to 'Double D' drive.
- ☑ Accurate dual stem sealing prevents leakage.
- ☑ Butterfly valve can be mounted between flanges as per ASME.
- ☑ 100% Tested With Pneumatic And Fluid (Water) Media.
- ☑ Design Standard : ISO 5211, API 609, ASME B16.5 150#.
- ☑ Face to Face Dimension : API 609 (CAT A).
- ☑ Operator mounting flange : As per ISO 5211.
- ☑ Operator : Hand Lever / Gear / Actuator
- ☑ Leakage Class : 100% tightness at full differential Pressure.

Hand Lever Operated Wafer Type Butterfly Valve

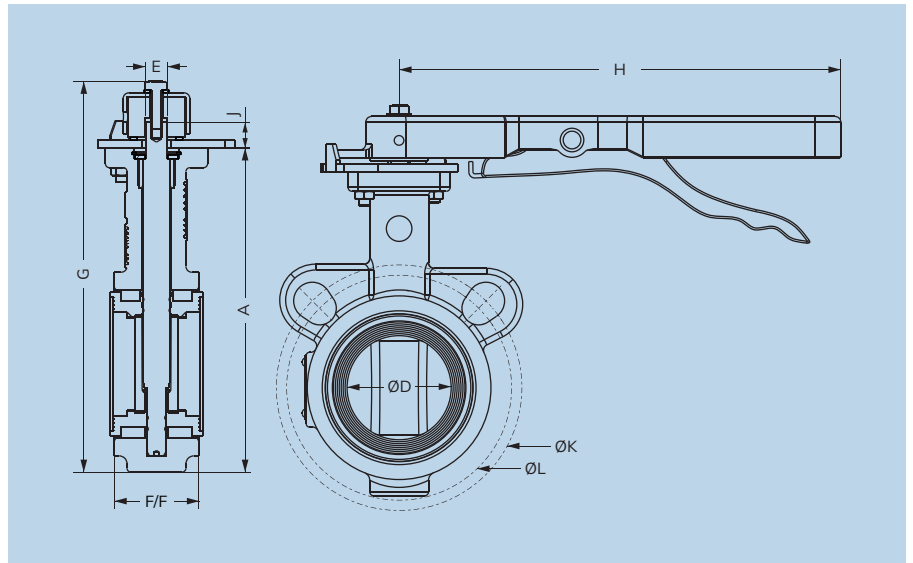

Technical Data (All dimensions are in mm)

All dimensions are approx.

Size	A	ØD	F/F	ØK	ØL	G	J	H	E	MOUNTING FLANGE
40 MM	140	40	33	105	98	173	12	225	11	F05
50 MM	165	50	43	125	114	199	13	225	11	F05
65 MM	192	65	46	145	127	226	12	225	11	F05
80 MM	218	80	46	164	146	252	14	225	11	F05
100 MM	243	100	52	190	179	275	17	260	14	F07
125 MM	276	125	56	216	200	310	20	260	17	F07
150 MM	310	150	56	241	225	344	19	260	17	F07
200 MM	404	200	60	298	292	442	22	290	22	F07/F10
250 MM	470	250	68	362	350	510	25	290	22	F07/F10

Pneumatic Operated Wafer Type Butterfly Valve - PN10

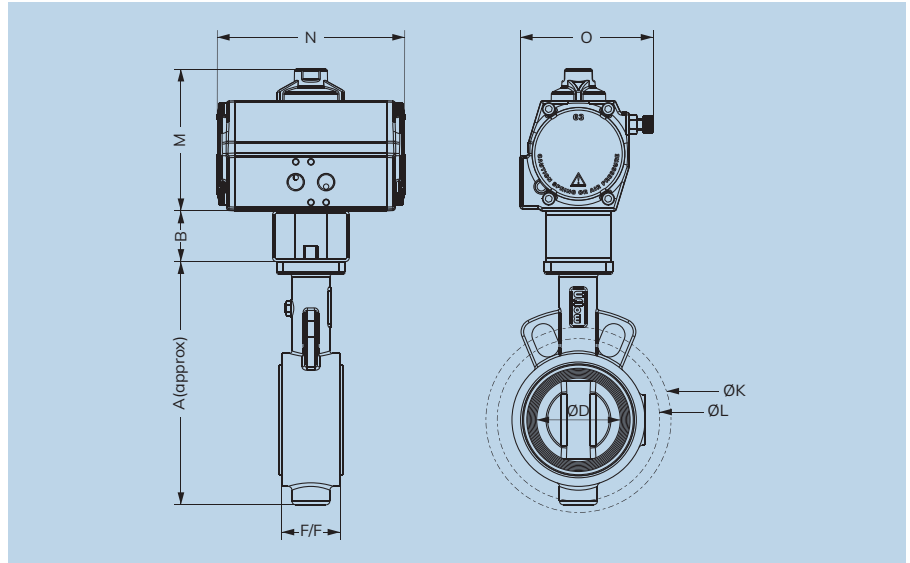

Technical Data - Butterfly Valve with Double Acting Actuator (All dimensions are in mm)

All dimensions are approx.

Size	Actuator	Coupler	A	B	ØD	F/F	ØK	ØL	M	N	O	Mounting Flange
40 MM	50	NA	140	-	40	33	105	98	99	130	85	F05
50 MM	50	NA	165	-	50	43	125	114	99	130	85	F05
65 MM	50	NA	192	-	65	46	145	127	99	130	85	F05
80 MM	50	NA	218	-	80	46	164	146	99	130	85	F05
100 MM	63	NA	243	-	100	52	190	179	112	147	105	F07
125 MM	80	NA	276	-	125	56	216	200	128	170	114	F07
150 MM	80	NA	310	-	150	56	241	225	128	170	114	F07
200 MM	100	NA	404	-	200	60	298	292	154	220	150	F07/F10
250 MM	125	NA	470	-	250	68	362	350	185	389	174	F07/F10
300 MM	150	NA	562	-	300	78	432	400	219	465	205	F12

Technical Data - Butterfly Valve with Single Acting Actuator (All dimensions are in mm)

All dimensions are approx.

Size	Actuator	Coupler	A	B	ØD	F/F	ØK	ØL	M	N	O	Mounting Flange
40 MM	50	NA	140	-	40	33	105	98	99	162	85	F05
50 MM	50	NA	165	-	50	43	125	114	99	162	85	F05
65 MM	63	C1455V0	192	40	65	46	145	127	112	202	105	F05
80 MM	80	C1755V0	218	40	80	46	164	146	128	234	114	F05
100 MM	100	C4277V0	243	40	100	52	190	179	153	324	151	F07
125 MM	100	C7277V0	276	40	125	56	216	200	153	324	151	F07
150 MM	125	C7270V0	310	61	150	56	241	225	185	389	173	F07
200 MM	150	C2800V0	404	61	200	60	298	292	219	465	205	F07/F10
250 MM	150	C2800V0	470	61	250	68	362	350	219	465	205	F07/F10

Pneumatic Operated Wafer Type Butterfly Valve - PN16

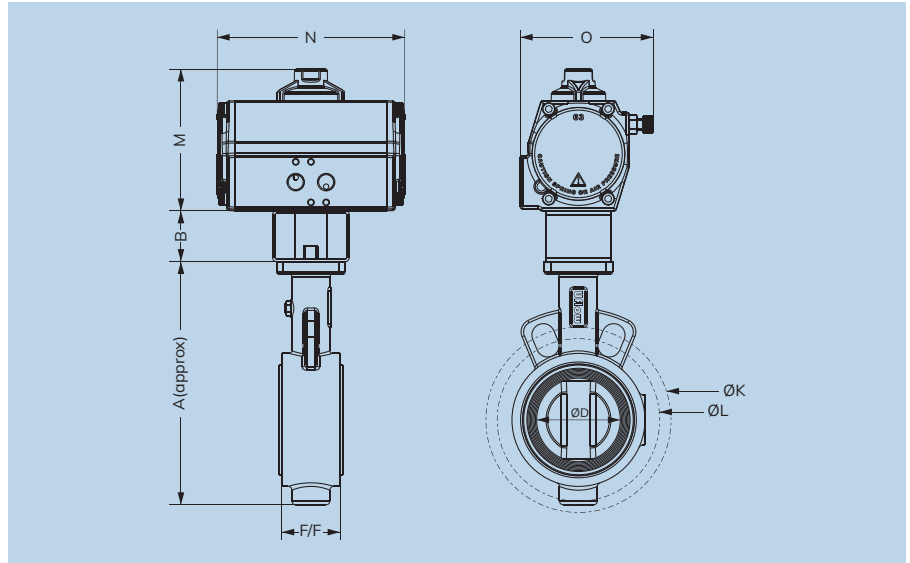

Technical Data - Butterfly Valve With Double Acting Actuator (All dimensions are in mm)

All dimensions are approx.

Size	Actuator	Coupler	A	B	ØD	F/F	ØK	ØL	M	N	O	Mounting Flange
40 MM	50	NA	140	-	40	33	105	98	99	130	85	F05
50 MM	50	NA	165	-	50	43	125	114	99	130	85	F05
65 MM	50	NA	192	-	65	46	145	127	99	130	85	F05
80 MM	63	C1455V0	218	40	80	46	164	146	112	147	105	F05
100 MM	80	C4777V0	243	40	100	52	190	179	128	170	114	F07
125 MM	80	NA	276	-	125	56	216	200	128	170	114	F07
150 MM	100	C7277V0	310	40	150	56	241	225	154	220	150	F07
200 MM	125	NA	404	-	200	60	298	292	185	389	174	F07/F10
250 MM	150	C2800V0	470	61	250	68	362	350	219	465	205	F07/F10

Technical Data - Butterfly Valve With Single Acting Actuator (All dimension are in mm)

All dimensions are approx.

Size	Actuator	Coupler	A	B	ØD	F/F	ØK	ØL	M	N	O	Mounting Flange
40 MM	63	C1455V0	140	40	40	33	105	98	112	202	105	F05
50 MM	80	C1755V0	165	40	50	43	125	114	128	234	114	F05
65 MM	80	C1755V0	192	40	65	46	145	127	128	234	114	F05
80 MM	100	C1257V0	218	40	80	46	164	146	153.5	324	151	F05
100 MM	100	C4277V0	243	40	100	52	190	179	153.5	324	151	F07
125 MM	125	C7270V0	276	61	125	56	216	200	185	389	173	F07
150 MM	150	C7870V0	310	61	150	56	241	225	219	465	205	F07

Gear Box Operated Wafer Type Butterfly Valve

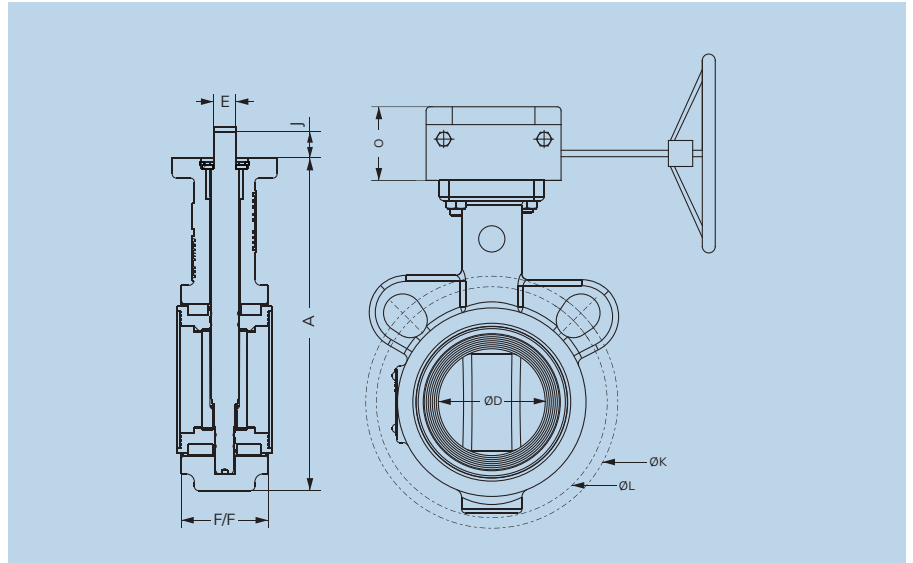

Technical Data (All dimensions are in mm)

All dimensions are approx.

Size	A	ØD	F/F	ØK	ØL	E	J	O	Mounting Flange
40 MM	140	40	33	105	98	11	12	50	F05
50 MM	165	50	43	125	114	11	13	50	F05
65 MM	192	65	46	145	127	11	12	50	F05
80 MM	218	80	46	164	146	11	14	50	F05
100 MM	243	100	52	190	179	14	17	53	F07
125 MM	276	125	56	216	200	17	20	53	F07
150 MM	310	150	56	241	225	17	19	53	F07
200 MM	404	200	60	298	292	22	22	63	F07/F10
250 MM	470	250	68	362	350	22	25	63	F07/F10
300 MM	561	300	78	432	399	27	32	70	F12

Applicable Flange Mounting

SIZE	ANSI	DIN 1092			BS10			JIS		
	150#	PN6	PN10	PN16	TABLE-E	TABLE-F	TABLE-H	5K	10K	16K
DN40	OK	OK	NA	NA	OK	OK	OK	NA	OK	NA
DN50	OK	OK	OK	OK	OK	OK	OK	NA	OK	NA
DN65	OK	OK	OK	OK	OK	OK	OK	OK	OK	OK
DN80	OK	OK	OK	OK	OK	OK	OK	OK	OK	NA
DN100	OK	NA	OK	OK	OK	OK	OK	NA	NA	NA
DN125	OK	OK	OK	OK	OK	NA	NA	OK	NA	NA
DN150	OK	OK	OK	OK	OK	NA	NA	OK	OK	NA
DN200	OK	NA	OK	OK	OK	NA	NA	NA	NA	NA
DN250	OK	NA	OK	NA	OK	NA	NA	NA	OK	NA
DN300	OK	NA	OK	NA	OK	NA	NA	NA	NA	NA

WAFER END BUTTERFLY VALVE MODEL IDENTIFICATION CHART

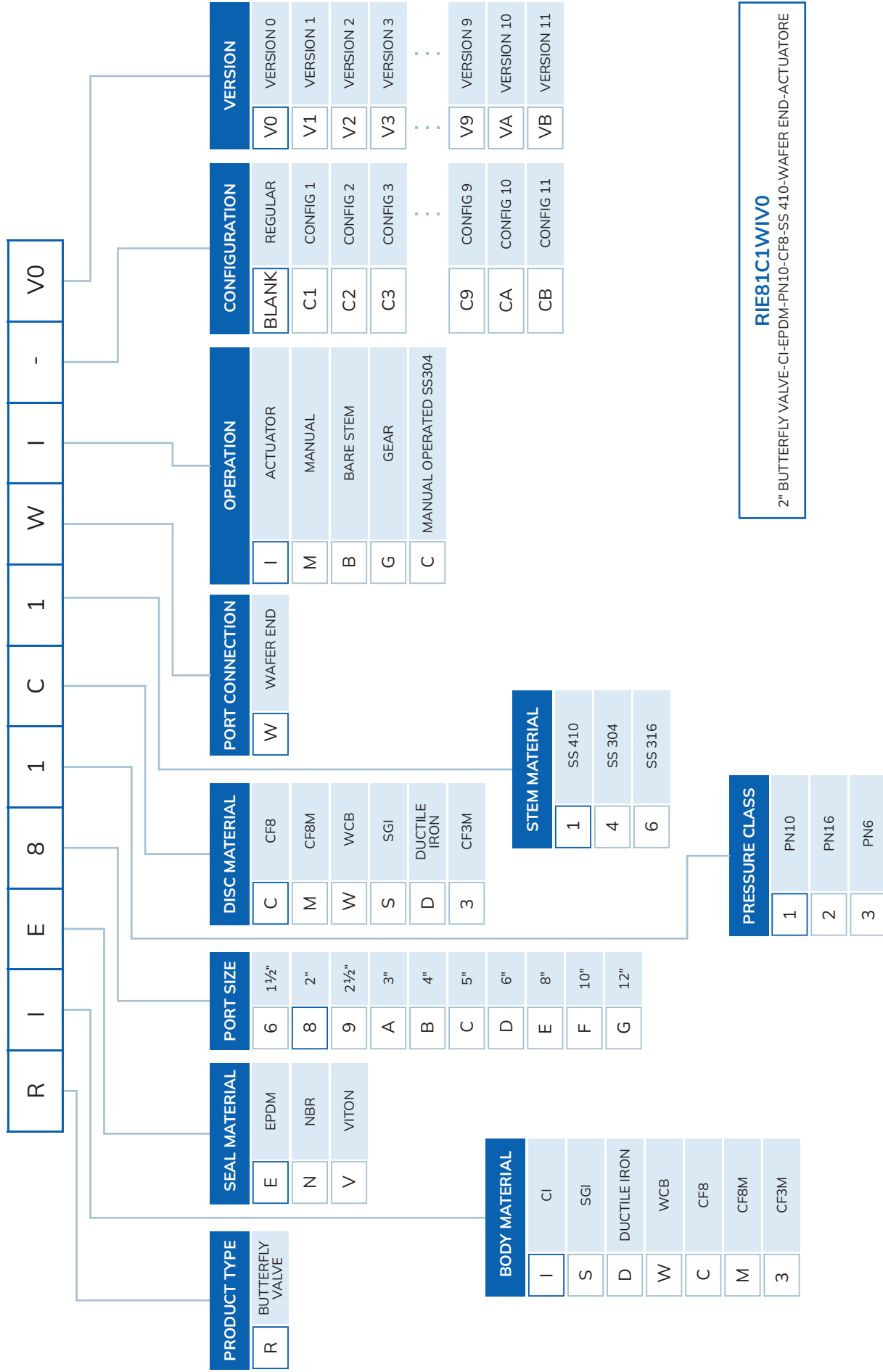

Specifications

End Connection :	Lug
Size :	DN50 - DN300
Suitable :	ASME B16.5 150#
Pressure Range :	PN06, PN10, PN16
Leakage Class :	100% Tightness at fully differential pressure
Standard :	API 609, BS 5155, ISO 5211, API 598, ASME B16.5
Body Material :	Cast Iron(CI), SGI, WCB, CF8, CF8M
Disc Material :	SGI, CF8, CF8M, WCB
Stem Material :	SS410, SS304, SS316
Body Liner / Seat Material :	NBR, EPDM, VITON
Shaft Bearing Material :	PTFE

Features

- ☑ Bi-directional zero leakage butterfly valve.
- ☑ ISO Pad for mounting, Gear Operator / Actuator
- ☑ Extremely small play between the stem and disc due to 'Double D' drive.
- ☑ Accurate dual stem sealing prevents leakage.
- ☑ Standard flanged drilling : PN10/PN16, JIS 10K/16K, ASME 125/150#
- ☑ 100% Tested With Pneumatic And Fluid (Water) Media.
- ☑ Design Standard : ISO 5211, API 609, ASME B16.5 150#.
- ☑ Face to Face Dimension : API 609 (CAT A).
- ☑ Operator mounting flange : As per ISO 5211.
- ☑ Operator : Hand Lever / Gear / Actuator
- ☑ Leakage Class : 100% tightness at full differential Pressure.

Hand Lever Operated Lug Type Butterfly Valve

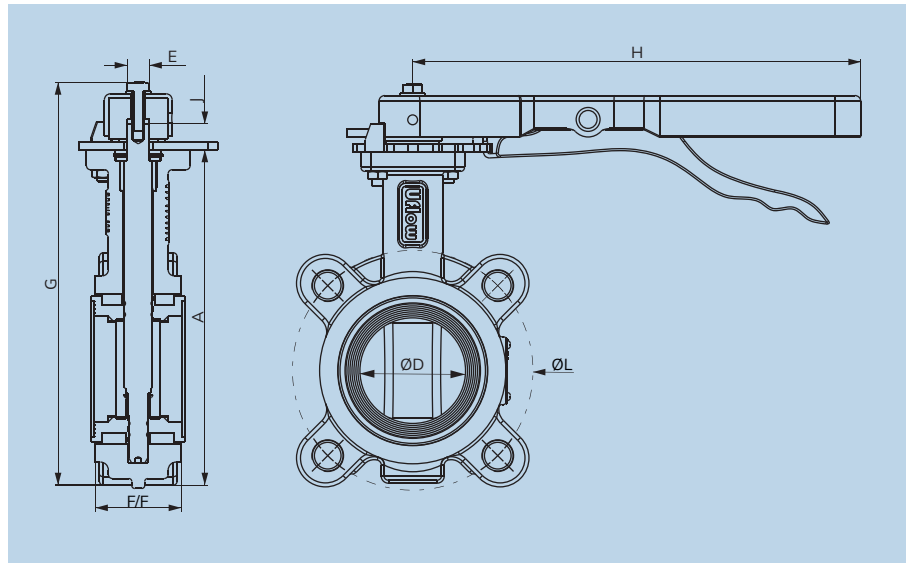

Technical Data (All dimensions are in mm)

All dimensions are approx.

Size	A	ØD	F/F	ØL	G	J	H	E	MOUNTING FLANGE
50 MM	170	50	43	120	204	13	225	11	F05
65 MM	192	65	46	140	226	12	225	11	F05
80 MM	219	80	46	152.5	252	14	225	11	F05
100 MM	258	100	52	190.5	289	17	260	14	F07
125 MM	287	125	56	216	320	20	260	17	F07
150 MM	318	150	56	241	353	19	260	17	F07
200 MM	393	200	60	298	431	22	290	22	F10
250 MM	465	250	68	362	505	25	290	22	F10

Pneumatic Operated Lug Type Butterfly Valve - PN10

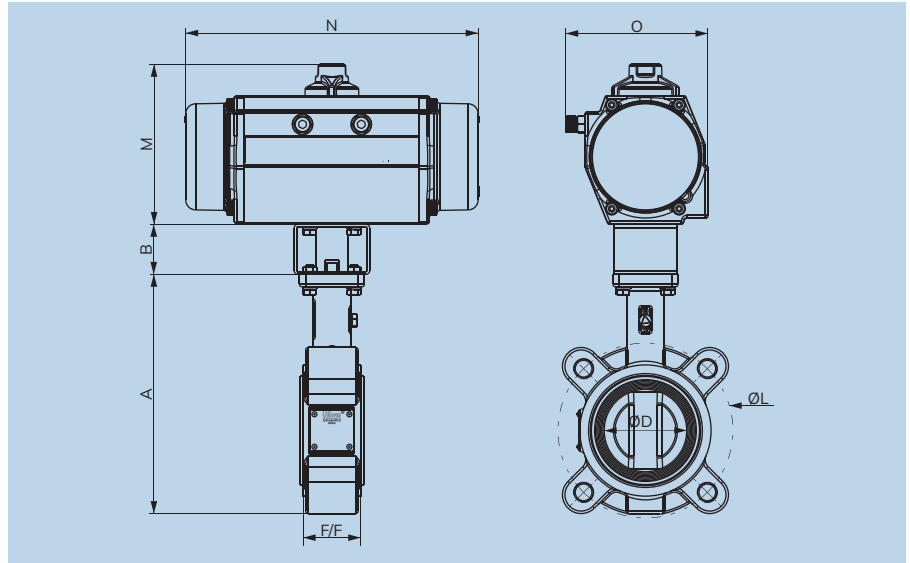

Technical Data - Butterfly Valve with Double Acting Actuator (All dimensions are in mm)

All dimensions are approx.

Size	Actuator	Coupler	A	B	ØD	F/F	ØL	M	N	O	Mounting Flange
50 MM	50	NA	170	-	50	43	120	99	130	85	F05
65 MM	50	NA	192	-	65	46	140	99	130	85	F05
80 MM	50	NA	219	-	80	46	152.5	99	130	85	F05
100 MM	63	NA	258	-	100	52	190.5	112	147	105	F07
125 MM	80	NA	287	-	125	56	216	128	170	114	F07
150 MM	80	NA	318	-	150	56	241	128	170	114	F07
200 MM	100	NA	393	-	200	60	298	154	220	150	F10
250 MM	125	NA	465	-	250	68	362	185	389	174	F10
300 MM	150	NA	552	-	300	78	432	219	465	205	F12

Technical Data - Butterfly Valve with Single Acting Actuator (All dimensions are in mm)

All dimensions are approx.

Size	Actuator	Coupler	A	B	ØD	F/F	ØL	M	N	O	Mounting Flange
50 MM	50	NA	170	-	50	43	120	99	162	84.9	F05
65 MM	63	C1455V0	192	40	65	46	140	112	202	105	F05
80 MM	80	C1755V0	219	40	80	46	152.5	128	234	114	F05
100 MM	100	C4277V0	258	40	100	52	190.5	153	324	151	F07
125 MM	100	C7277V0	287	40	125	56	216	153	324	151	F07
150 MM	125	C7270V0	318	61	150	56	241	185	389	173	F07
200 MM	150	C2800V0	393	61	200	60	298	219	465	205	F10
250 MM	150	C2800V0	465	61	250	68	362	219	465	205	F10

Pneumatic Operated Lug Type Butterfly Valve - PN16

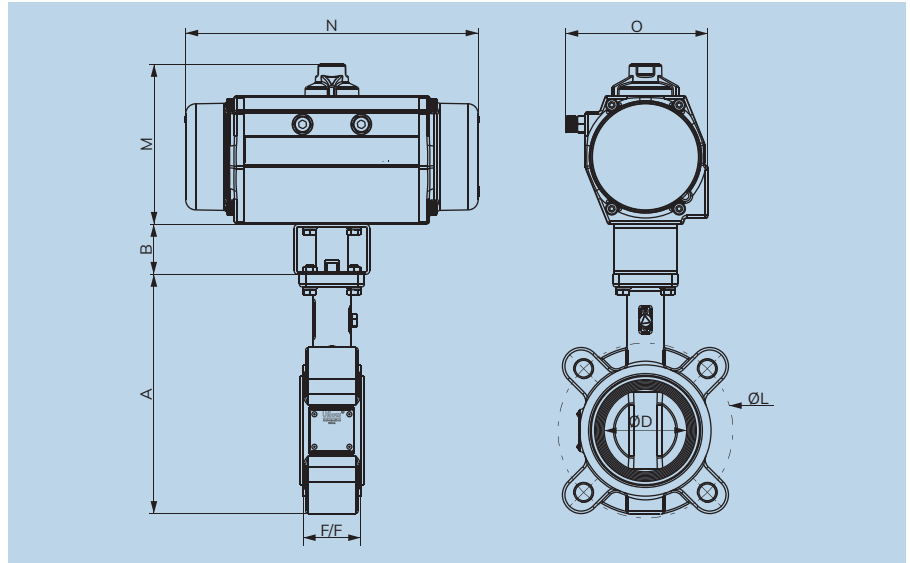

Technical Data - Butterfly Valve with Double Acting Actuator (All dimensions are in mm)

All dimensions are approx.

Size	Actuator	Coupler	A	B	ØD	F/F	ØL	M	N	O	Mounting Flange
50 MM	50	NA	170	-	50	43	120	99	130	85	F05
65 MM	50	NA	192	-	65	46	140	99	130	85	F05
80 MM	63	C1455V0	219	40	80	46	152.5	112	147	105	F05
100 MM	80	C4777V0	258	40	100	52	190.5	128	170	114	F07
125 MM	80	NA	287	-	125	56	216	128	170	114	F07
150 MM	100	C7277V0	318	40	150	56	241	154	220	150	F07
200 MM	125	NA	393	-	200	60	298	185	389	173	F10
250 MM	150	C2800V0	465	61	250	68	362	219	465	205	F10

Technical Data - Butterfly Valve with Single Acting Actuator (All dimension are in mm)

All dimensions are approx.

Size	Actuator	Coupler	A	B	ØD	F/F	ØL	M	N	O	Mounting Flange
50 MM	80	C1755V0	170	40	50	43	120	128	234	114	F05
65 MM	80	C1755V0	192	40	65	46	140	128	234	114	F05
80 MM	100	C1257V0	219	40	80	46	152.5	153.5	324	151	F05
100 MM	100	C4277V0	258	40	100	52	190.5	153.5	324	151	F07
125 MM	125	C7270V0	287	61	125	56	216	185	389	173	F07
150 MM	150	C7870V0	318	61	150	56	241	219	465	205	F07

Gear Box Operated Lug Type Butterfly Valve

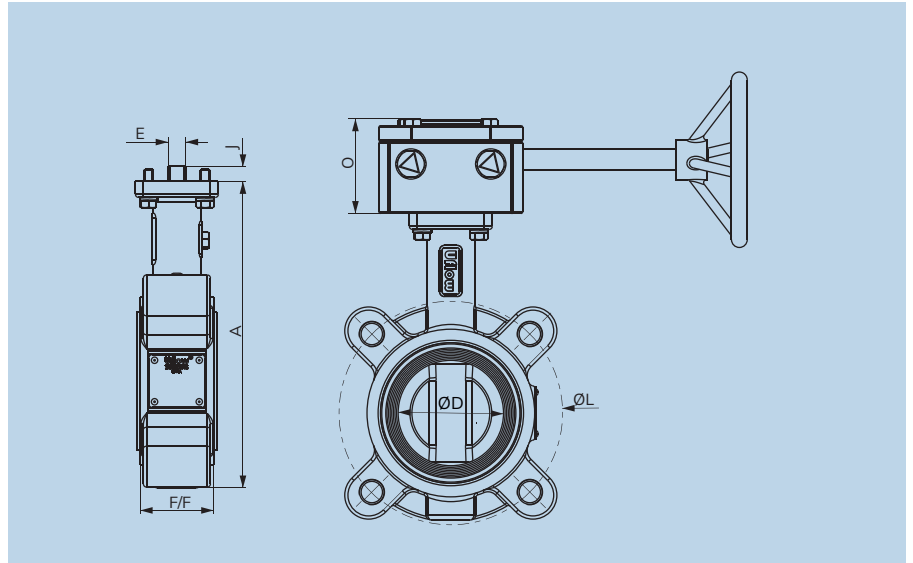

Technical Data (All dimensions are in mm)

All dimensions are approx.

Size	A	ØD	F/F	ØL	E	J	O	Mounting Flange
50 MM	170	50	43	120	11	13	50	F05
65 MM	192	65	46	140	11	12	50	F05
80 MM	219	80	46	153	11	14	50	F05
100 MM	258	100	52	191	14	17	53	F07
125 MM	287	125	56	216	17	20	53	F07
150 MM	318	150	56	241	17	19	53	F07
200 MM	393	200	60	298	22	22	63	F10
250 MM	465	250	68	362	22	25	63	F10
300 MM	552	300	78	432	27	32	70	F12

FULL LUG AND FLANGE END BUTTERFLY VALVE MODEL IDENTIFICATION CHART

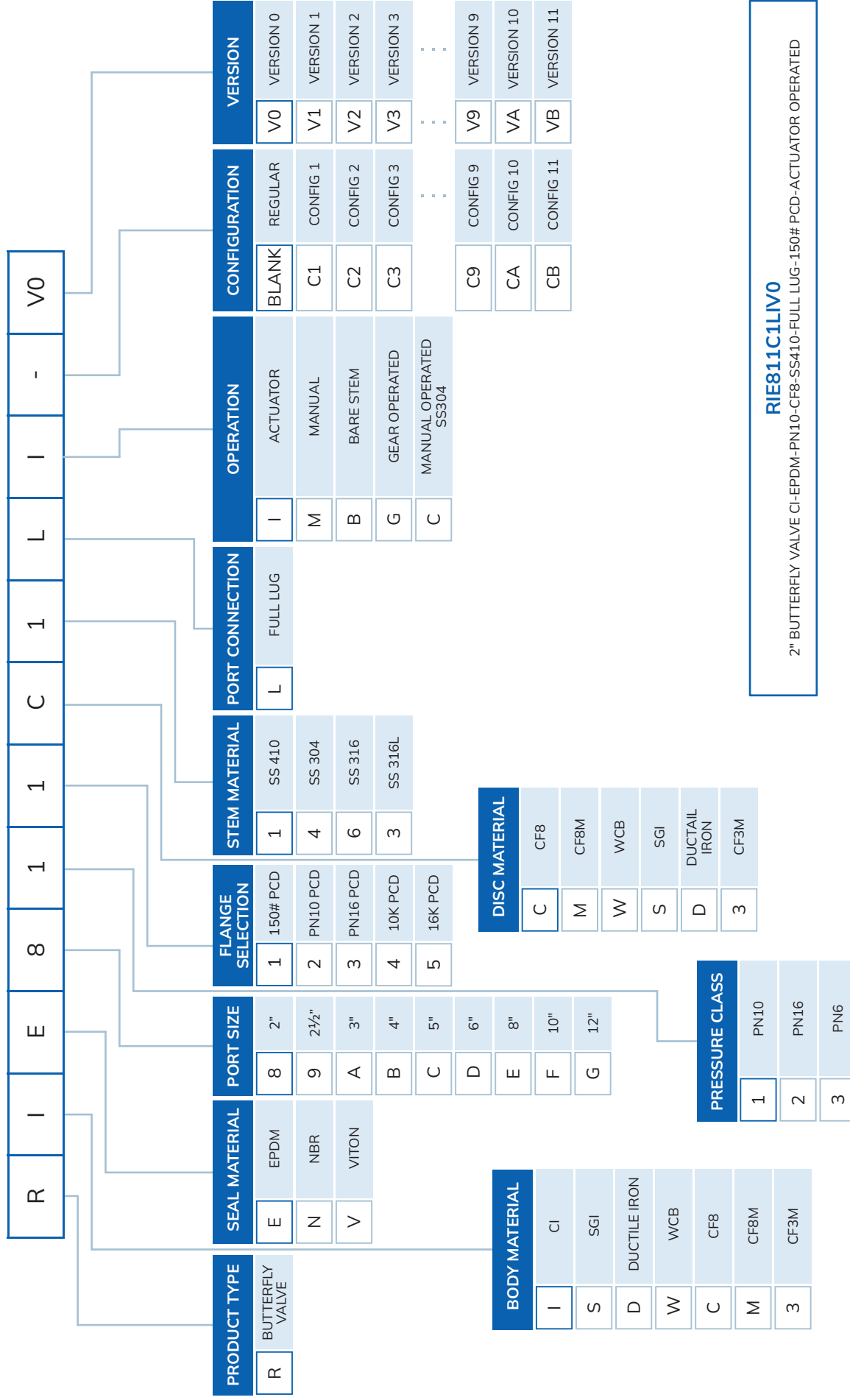

RIE811C1L1V0
2" BUTTERFLY VALVE CI-EPDM-PN10-CF8-SS410-FULL LUG-150# PCD-ACTUATOR OPERATED



Note: The above chart is for identification purposes only, and it may not be possible to make all combinations for the above chart.



LIMIT SWITCH
SERIES



Features for Compact Limit Switch

- ☑ Compact & Lightweight design
- ☑ Open / Close indicator visible from all directions.
- ☑ No extra attachment required for the indicator dome as it is inbuilt with a transparent cover.
- ☑ Cable entries with multiple connectivity option (M20 & 1/2" NPT).
- ☑ A stainless steel bracket is available as an option.
- ☑ Every adjustable serrated cam for fast & Fine switch adjustment & Also helpful for fine adjusting of feedback setting.
- ☑ Temperature range -20°C to +80°C
- ☑ Weatherproof limit switch.



Features for Standard Limit Switch

- ☑ Honeywell/ Cherry Microwitch Sensors
- ☑ Exproof to I, IIA, IIB, and IIC
- ☑ Aluminium Diecast, with powder coating, for superior corrosion resistance
- ☑ Easily settable colour coded cam
- ☑ The locked serrated cams, ensures the secured settings against any vibration
- ☑ Switch Box conforms to Ex d IIC, T6 Highest level of safety
- ☑ Special PCB eliminates all wiring from the switch element to the terminals. Complete protection against short circuit
- ☑ Temperature range -20 °C to +80 °C
- ☑ IP67 : Water, Rain and Dust Proof
- ☑ IP68 : Upto 100m on request
- ☑ Cable Entry M20, 1/2" NPT or 3/4" NPT
- ☑ ATEX EX d IIC, T6
- ☑ Shatterproof Polycarbonate Dome
- ☑ All fasteners are in Stainless Steel
- ☑ Up to Maximum 4 Sensor Elements

Dimension Drawing for Compact Limit Switch

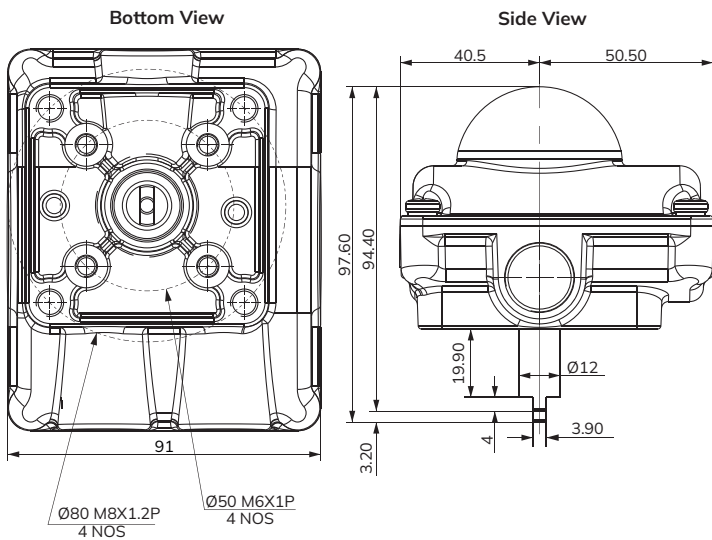

Dimension Drawing for Standard Limit Switch

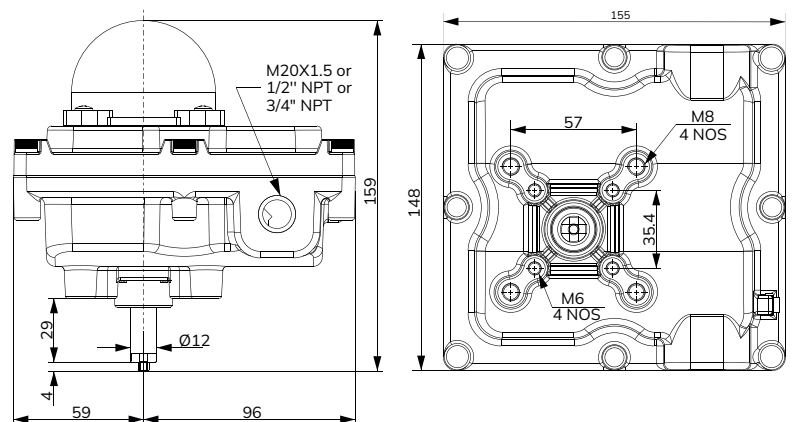

All dimensions in mm
All dimensions are approx.

LIMIT SWITCH MODEL IDENTIFICATION CHART

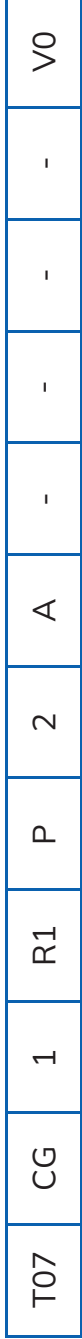

PRODUCT TYPE	SERIES	QUANTITY OF SWITCHES	ENCLOSURE MATERIAL	QUANTITY OF CONDUIT ENTRY	CABLE ENTRY	VISUAL INDICATOR	CONFIGURATION	VERSION
T07 Limit Switch	SG Standard Enclosure Type Limit Switch	1 1 SWITCH	P ALU + Plastic NOTE - Only with CG	2 2 Entries	A M20 X 1.5	- Red & Yellow	- REGULAR	V0 VERSION 0
	CG Compact Enclosure Type Limit Switch	2 2 SWITCH	A Diecast Aluminium	4 4 Entries	B 1/2" NPT	G Red & Green	C1 CONFIG 1	V1 VERSION 1
		4 4 SWITCH			C 3/4" NPT		C2 CONFIG 2	V2 VERSION 2
							C3 CONFIG 3	V3 VERSION 3
							⋮	⋮
							⋮	⋮
							C9 CONFIG 9	V9 VERSION 9
							CA CONFIG 10	VA VERSION 10
							CB CONFIG 11	VB VERSION 11

TEMP. RANGE
- General (-20 to +80°C)
C Cold Temp. (-40 to +80°C) (F2, R2 & W2)
H High Temp. (-20 to +100°C) (A1, D1, F1 & F2)

SWITCH TYPE	
R1	Honeywell V15S05-CZ100A05-01 SPDT 5 A, 125 Or 250 VAC, 100mA, 48 VDC (NO/NC), 30 mA, 250 VDC (NO/NC)
R2	Honeywell V7-1C17E9-201 SPDT 15 A, 125 Or 250 VAC, 500 mA, 125 VDC, (NO/NC) mA, 250 VDC (NO/NC)
W1	Honeywell V15S05-CZ100A05-01 DPDT 5 A, 125 Or 250 VAC, 100mA, 48 VDC (NO/NC), 30 mA, 250 VDC (NO/NC)
W2	Honeywell V7-1C17E9-201 DPDT 15 A, 125 Or 250 VAC, 500mA, 125 VDC, 250 mA, 250 VDC (NO/NC)
D1	P & F NJ2-V3-N FLAT 8V DC, 3mA, NC
D2	P & F NBB3-V3-Z4 FLAT 10-60V DC, 100mA, NO
F1	P & F SJ3.5-N SLOT 8V DC, > 3 mA; < 1 mA (NC)
F2	P & F SJ3.5-SN SLOT 8V DC, > 3 mA; < 1 mA (NC)
B1	P & F NJ2-V3-N Flat Limit Switch Having Total 4 Sensors 2 Open & 2 Close 8V DC, 3mA, NC
A1	P & F NJ2-12GM-N Cylindrical -
A2	P & F NBN4-12GM40-Z0 Cylindrical -

APPROVALS
- No Approval
A ATEX / IECEx Exd NOTE - Only with SG
P PESO NOTE - Only with SG
C CE
B BIS NOTE - Only with SG
E IP65 NOTE - Only with CG
I IP67 NOTE - Only with SG

T07CG1R1P2AV0
COMPACT ENCLOSURE TYPE LIMIT SWITCH-ALU+PLATIC-SPDT-1 SWITCH-2 ENTRIES-M20X1.5

Note: The above chart is for identification purposes only, and it may not be possible to make all combinations for the above chart.



ROTO SEAL COUPLING SERIES

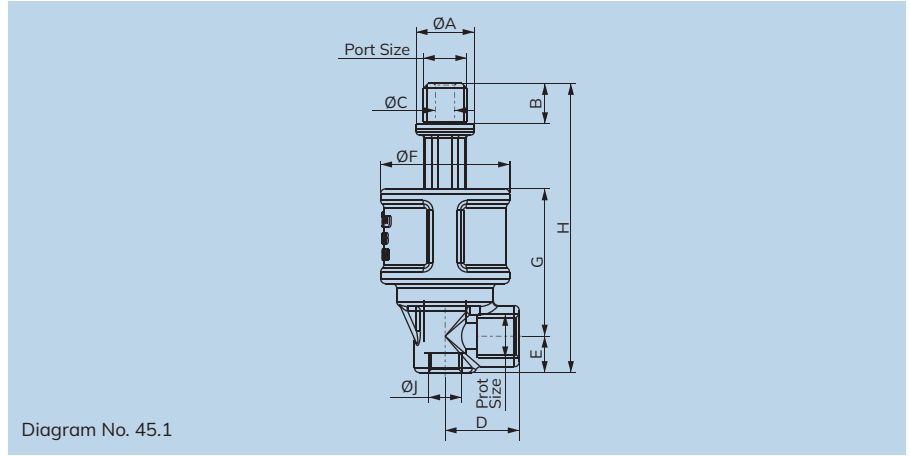
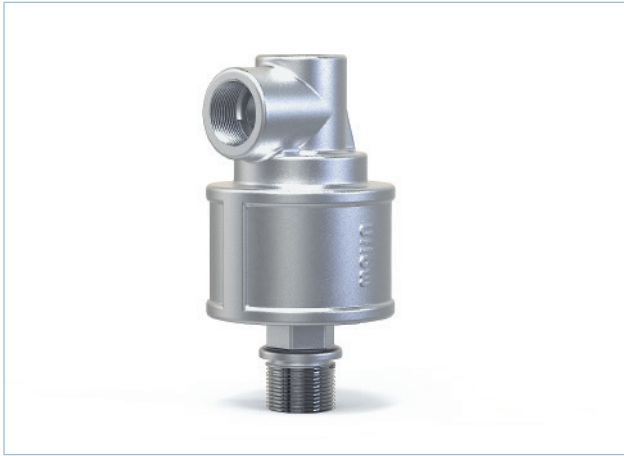

Specifications

Port :	¼", ⅜", ½", ¾", 1", 1¼", 1½" & 2" (Available BSP / NPT)
Media :	Air, Water, Oil & Gas
Pressure :	Upto 10 bar
Temperature :	Viton (FKM) -10°C to 180°C
RPM :	1000 RPM

Section View

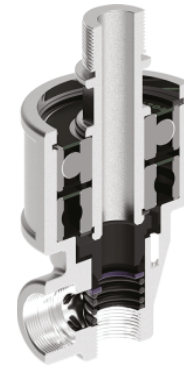

Features

- High-Performance Bearings & Seals.
- Dual Connection Available.

Technical Data (All dimensions in mm)

All Dimensions are approx.

Model No.	Diagram No.	Body Material	Port Size	Seal Material	A	B	C	D	E	F	G	H	J
UCV1BLV0 / UCV1BRV0	45.1	CF8 / CF8M	¼"	VITON	18	14	6	23	12	40	45	90	⅛"
UCV7BLV0 / UCV7BRV0	45.1	CF8 / CF8M	⅜"	VITON	22	14	10	23	13	48	53	99	¼"
UCV2BLV0 / UCV2BRV0	45.1	CF8 / CF8M	½"	VITON	26	16	12	28	17	56	61	106	⅜"
UCV3BLV0 / UCV3BRV0	45.1	CF8 / CF8M	¾"	VITON	32	19	19	40	21	72	72	145	½"
UCV4BLV0 / UCV4BRV0	45.1	CF8 / CF8M	1"	VITON	39	25	24	44	28	83	84	171	¾"
UCV5BLV0 / UCV5BRV0	45.1	CF8 / CF8M	1¼"	VITON	48	27	32	49	32	95	98	193	1"
UCV6BLV0 / UCV6BRV0	45.1	CF8 / CF8M	1½"	VITON	54	27	36	48	32	95	98	193	1¼"
UCV8BLV0 / UCV8BRV0	45.1	CF8 / CF8M	2"	VITON	68	32	47	62	40	123	124	269	1½"

ROTO SEAL MODEL IDENTIFICATION CHART

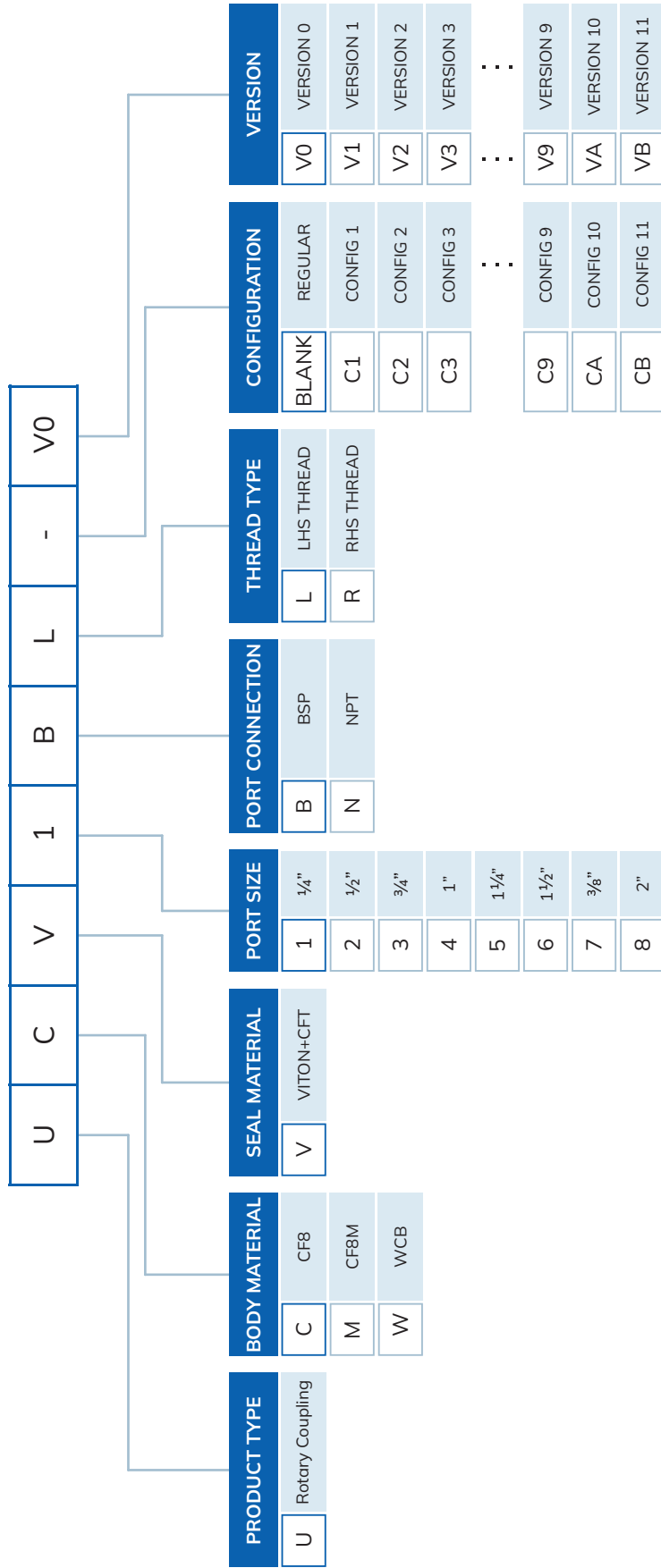

UCV1BLV0
1/4" ROTARY COUPLING CF8-VITON+CFT-BSP-LHS THREAD

Note: The above chart is for identification purposes only, and it may not be possible to make all combinations for the above chart.



IRRIGATION SERIES

Diaphragm Valve Specifications

Port :	Refer below technical data sheet (Available BSPT / NPT)
End Connection :	Screwed
Body Material :	Nylon GF
Diaphragm :	Natural Rubber
Max Media Temp :	60°C
Circumstance Temp :	-10°C to 60°C
Media :	Water
Main Features :	Internal Parts are in superior corrosion resistance steel, Suitable for irrigation.

2 Way - 3 Way Valve Specifications

Port :	Refer below technical data sheet (Available BSPT / NPT)		
End Connection :	Screwed		
Body Material :	Nylon GF		
Seal & 'O'Ring :	Nitrile (NBR)		
Max Media Temp :	5°C to 50°C		
Circumstance Temp :	-10°C to 50°C		
Media :	Water		
Main Features :	Internal Parts are in superior corrosion resistance steel, (Equivalent to SS316L) Suitable for irrigation.		
Operating Voltage :	24AC	12DC	24DC - Latching
Power Consumption :	8W	3W	8W - Latch, 3W - Delatch
Coil Features :	High Reliability Unaffected by Voltage Surges. Easy coil changes coil lockable in 4X90 position or freely movable in between as require.		
Other Specification Data :	Available on Request.		

Diaphragm Valve Specifications

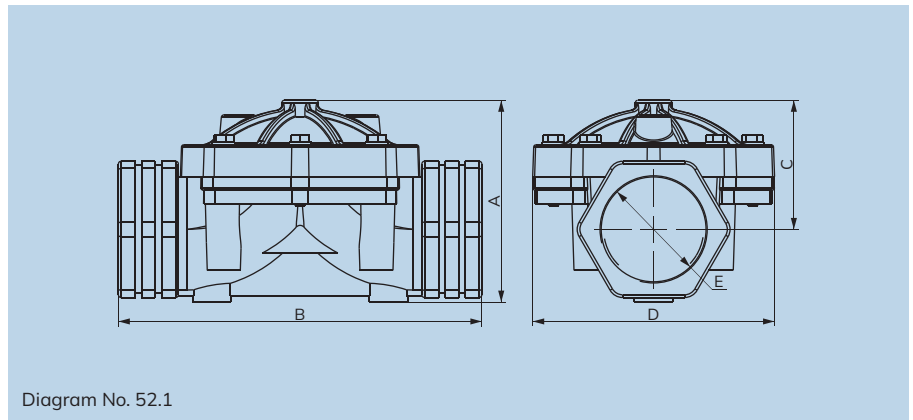

Technical Data

Model No.	Body Material	Pipe (Inch)	Min. Operating Pressure Kg/cm ²	Max. Operating Pressure Kg/cm ²	Seal & Diaphragm Material	Flow Factor Kv m ³ / hr
ENA622PV0	Nylon GF	1½"	1	10	Natural Rubber	60
ENA822PV0	Nylon GF	2"	1	10	Natural Rubber	70
ENA922PV0	Nylon GF	2½"	1	10	Natural Rubber	80
ENAA22PV0	Nylon GF	3"	1	10	Natural Rubber	90
ENAB22PV0	Nylon GF	4"	1	10	Natural Rubber	190

Dimension (All dimensions in mm)

Model No.	Diagram No.	A	B	C	D	E
ENA622PV0	52.1	111	200	71	133	1½"
ENA822PV0	52.1	111	200	71	133	2"
ENA922PV0	52.1	138	250	87	160	2½"
ENAA22PV0	52.1	138	250	87	160	3"
ENAB22PV0	52.1	316	352	203	Ø225	4"

EXTERNAL PILOT OPERATED DIAPHRAGM VALVE MODEL IDENTIFICATION CHART

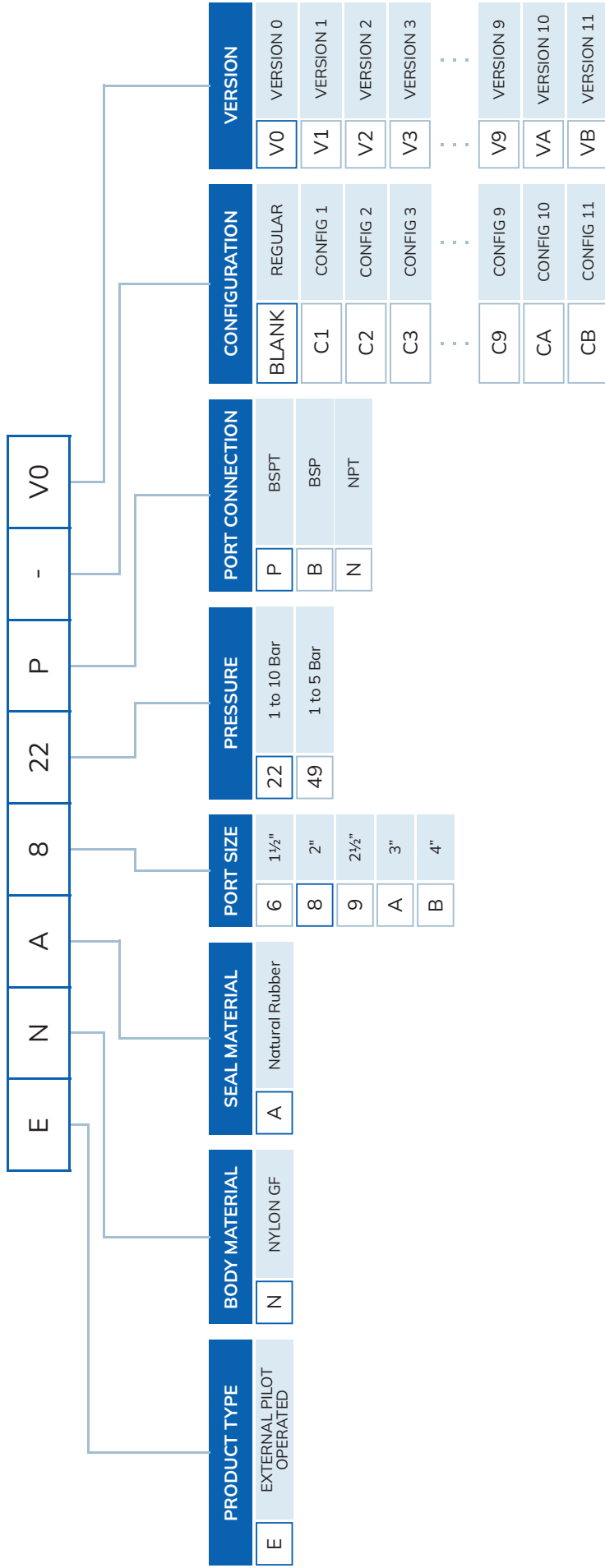

ENA822PV0
2" EXTERNAL PILOT OPERATED NYLON GF-NATURAL RUBBER-1 TO 10 Bar-BSPT

Note: The above chart is for identification purposes only, and it may not be possible to make all combinations for the above chart.

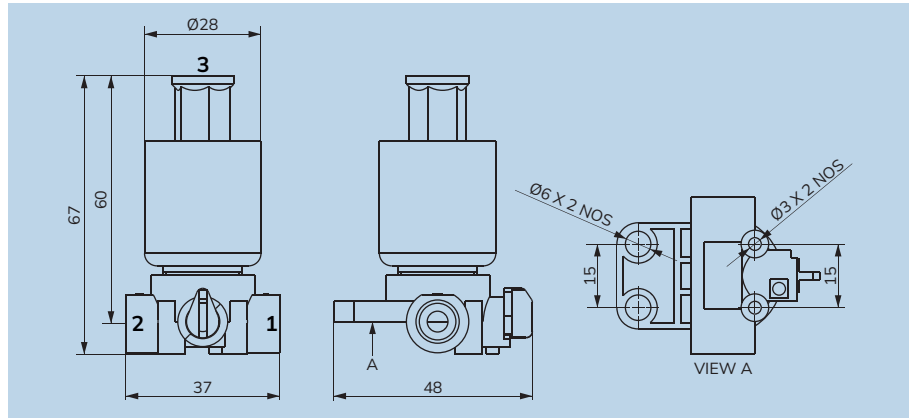

Technical Data

Model No.	Valve Type	Body Material	Pipe (Inch)	Orifice(mm)	Min. Operating Pressure Kg/cm ²	Max. Operating Pressure Kg/cm ²	Seal & Diaphragm Material	Flow Factor Kv m ³ / hr
DNN004PNDM016V0	2 Way	Nylon GF	1/8"	1.6	0	10	NITRILE (NBR)	0.07
TNN004PZCM012V0	3 Way	Nylon GF	1/8"	1.2	0	10	NITRILE (NBR)	0.042
TNN004PZU3012V0	3 Way	Nylon GF	1/8"	1.2	0	10	NITRILE (NBR)	0.042

Pipe Connection

Valve Position	Valve Type	Port No. - 1	Port No. - 2	Port No. - 3
Normally Close	3 Way	Input	Output	Exhaust
Normally Open	3 Way	Exhaust	Output	Input
Normally Close	2 Way	Output	Input	-

2 WAY - 3 WAY DIRECT ACTING PILOT SOLENOID VALVE MODEL IDENTIFICATION CHART

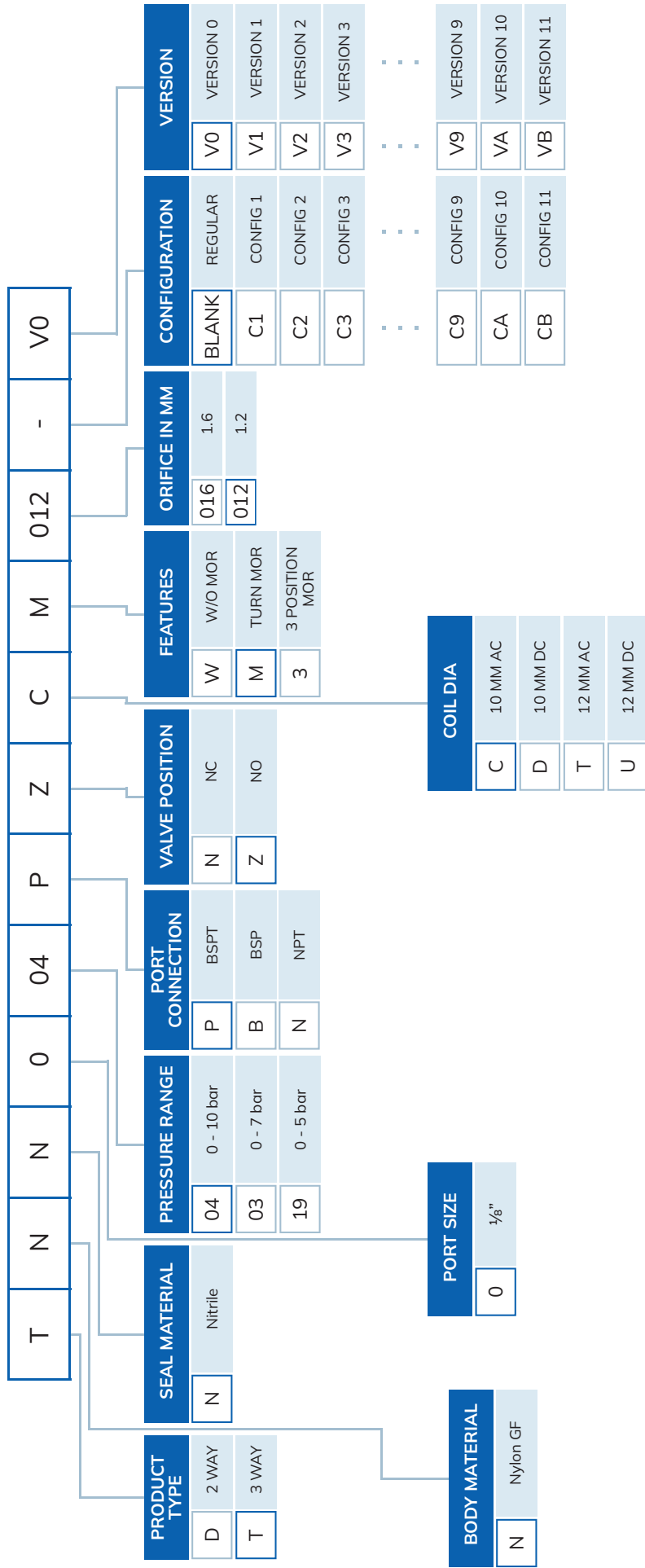

TNN004PZCM012V0

1/8" 3 WAY DIRECT ACTING NYLON GF-NITRILE-0 TO 10 Bar-BSPT-NO-10MM AC-TURN MOR-1.2MM ORIFICE

Note: The above chart is for identification purposes only, and it may not be possible to make all combinations for the above chart.

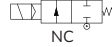
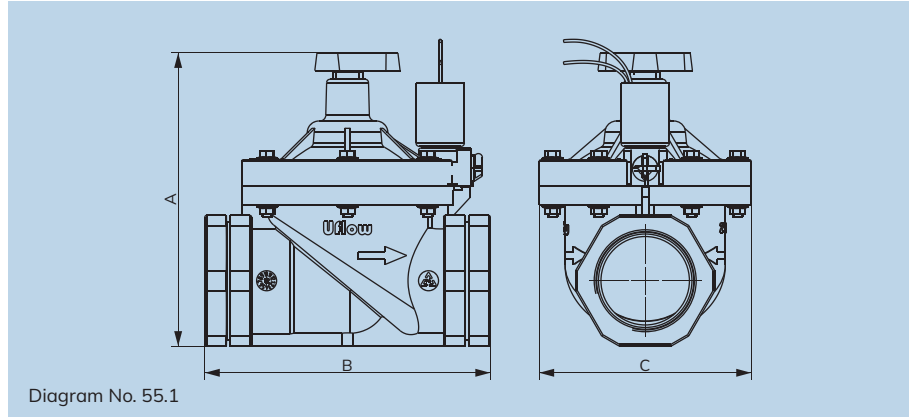

Specifications

Port :	¾", 1", 1½" & 2" (Available in BSP / BSPT / NPT)		
End Connection :	Screwed		
Body Material :	Nylon GF		
Diaphragm :	Natural Rubber		
Max Media Temp :	5°C to 50°C		
Ambient Temp :	-10°C to 50°C		
Media :	Water		
Operating Voltage :	24AC	24DC	12DC
Power Consumption :	8W	8W	8W
Coil Features :	High Reliability Unaffected by Voltage Surges. Easy coil changes coil lockable in 4X90 position or freely movable in between as require.		
Coil Housing :	IP65 Epoxy square coil, IP65 Metallic round enclosure, IP68 Weatherproof enclosure.		
Other Specification Data :	Available on Request		

NOTE: Use of filter in the inlet port is recommended.

Feature

- Inbuilt Flow Control Capabilities.
- Manual Override in All The Valve.
- Pressure Below Seat to Reduce Water Hummer.
- Low Head Loss With High Flow.

Technical Data

Model No.	Body Material	Pipe (Inch)	Orifice (mm)	Min. Operating Pressure mbar	Max. Operating Pressure bar	Seal & Diaphragm Material	Flow Factor Kv m ³ / hr
PNA306BNTFV0	Nylon GF	¾"	20	0.5	10	Natural Rubber	8
PNA406BNTFV0	Nylon GF	1"	25	0.5	10	Natural Rubber	12
PNA606BNTFV0	Nylon GF	1½"	40	0.5	10	Natural Rubber	23
PNA806BNTFV0	Nylon GF	2"	52	0.5	10	Natural Rubber	38

Dimension (All dimensions are in mm)

All Dimensions are approx.

Model No.	Port Size	Diagram No.	A	B	C
PNA306BNTFV0	¾"	55.1	108	110	81
PNA406BNTFV0	1"	55.1	114	110	81
PNA606BNTFV0	1½"	55.1	180	160	126
PNA806BNTFV0	2"	55.1	190	170	126

Section View

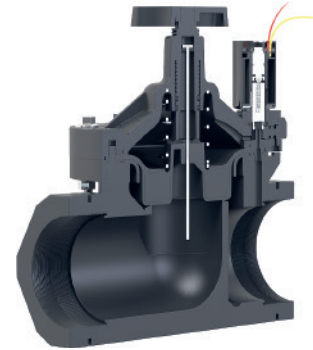

PILOT OPERATED DIAPHRAGM TYPE PLASTIC SOLENOID VALVE MODEL IDENTIFICATION CHART

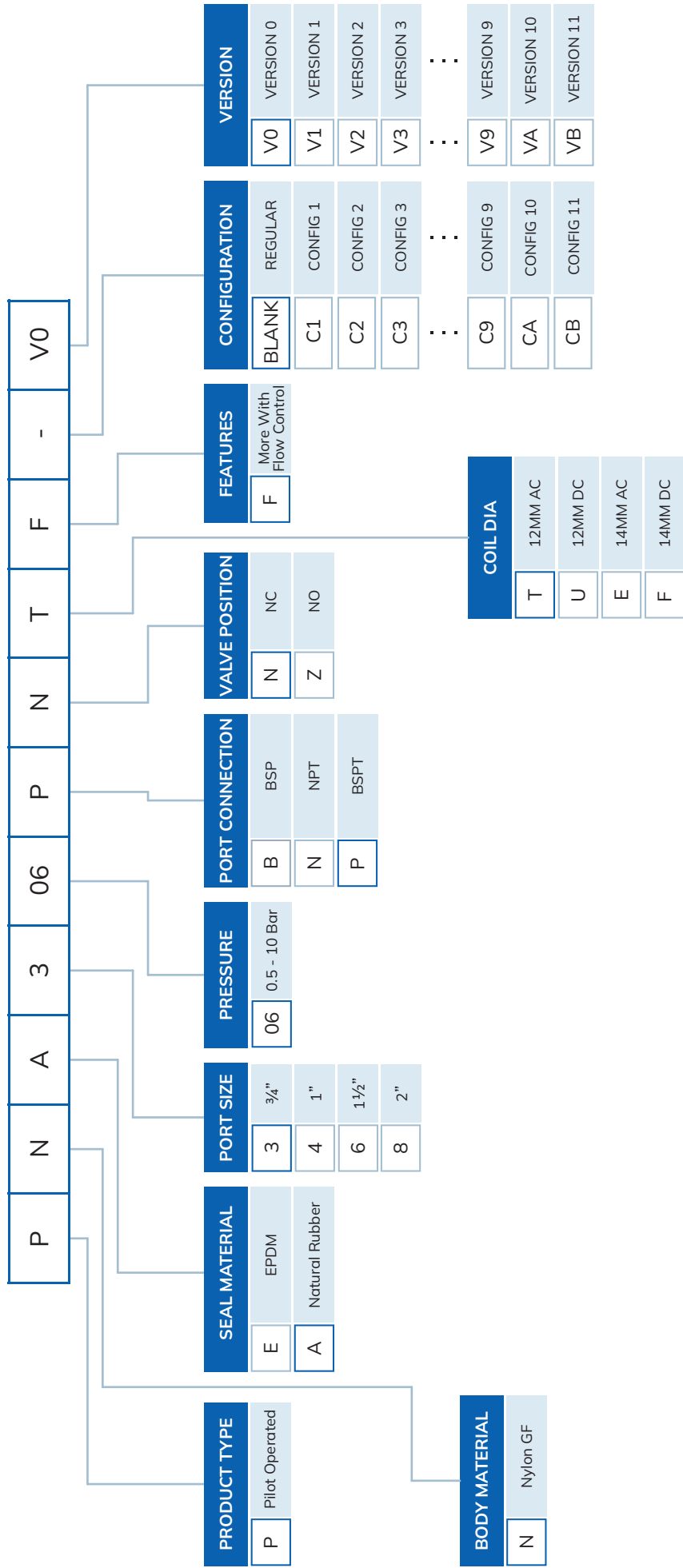

PNA306PNTFV0

3/4" PILOT OPERATED DIAPHRAGM NYLON GF-NATURAL RUBBER-0.5 TO 10-BSPT-NC-12MM AC-MOR WITH FLOW CONTROL



MEDICAL VALVES & REGULATOR SERIES

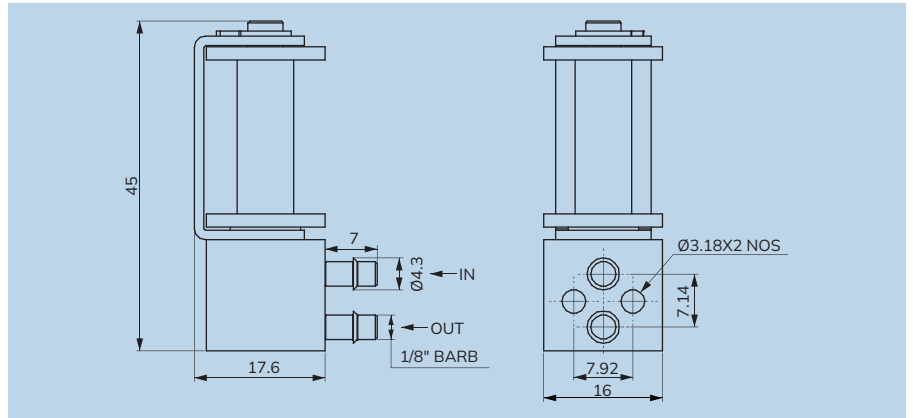
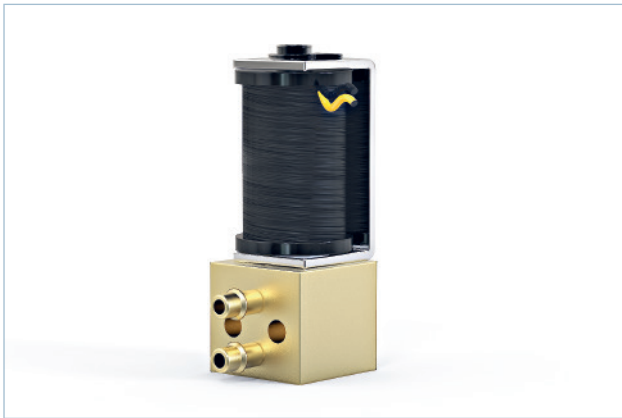

Specifications

Valve Type:	2 Way Normally Closed Proportional Valve
Port:	1/8" BARB, Manifold Mounting
Body Material:	Brass
Seal:	NBR Optional FKM, Viton
Media:	Air, Oxygen, Nitrous Oxide, Carbon Dioxide, Heliox & Other Medical Gases
Main Features :	Flow adjustment, Opening time adjustment, Quick release initial flow adjustment
LPM:	6LPM @ 10PSI Differential Pressure
Operating Environment:	32°F to 132°F (0°C to 55°C)
Storage Temperature:	-40°F to 158°F (-40°C to 70°C)
Dimensions:	L-17.6mm, W-16mm, H-45mm
Weight:	58g
Power:	9V DC (2 Watts)
Electric Termination:	15" Lead Wire
Stem Base:	Stainless steel
All Others:	NBR/FKM, Stainless Steel, Aluminium(Manifold)

Features

- Low power consumption generates less heat
- Proven performance tested to 100 million life cycles
- Uses either DC current or pulse width modulation with closed loop feedback to deliver optimal system performance.

Applications

- Ventilators
- Anesthesia Delivery & Monitors
- Insufflators
- Pressure and Flow Control

Performance Characteristics

Leak Rate:	<0.2 sccm of helium (bubble tight)
Hysteresis:	25% of full scale current (Max)
Response time:	10ms Typical
Reliability:	100 Million Cycles, 0.95 Reliability Factor, 95% Confidence Interval

NOTE: Contact for customized configuration: eg custom calibration and electrical connections.

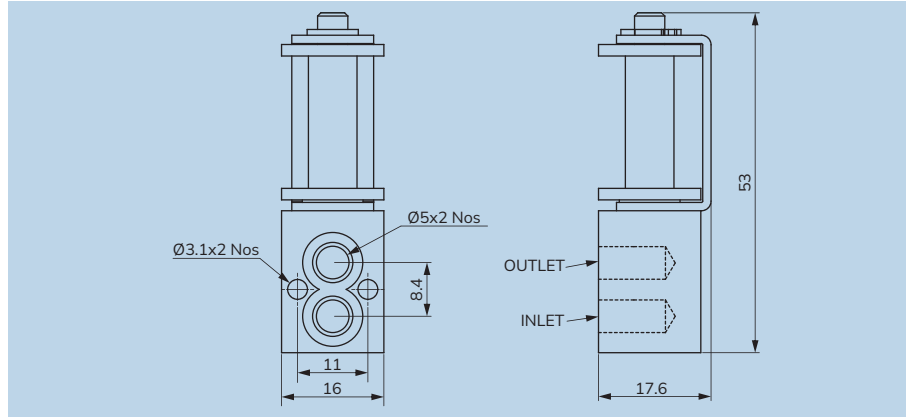

Specifications

Valve Type:	2 Way Normally Closed Proportional Valve
Port:	Manifold Mounting
Body Material:	Brass
Seal:	Silicon
Media:	Air, Oxygen, Nitrous Oxide, Carbon Dioxide, Heliox & Other Medical Gases
LPM:	150LPM @ 35PSI Differential Pressure
Operating Environment:	32 °F to 132 °F (0 °C to 55 °C)
Storage Temperature:	-40 °F to 158 °F (-40 °C to 70 °C)
Dimensions:	L-17.6mm, W-16mm, H-53mm
Weight:	56g
Power:	12V DC (2.5 Watts)
Electric Termination:	15" Lead Wire
Stem Base:	Stainless steel
All Others:	Silicon, VITON, Stainless Steel, Aluminium(Manifold)

Features

- Low power consumption generates less heat
- Proven performance tested to 100 million life cycles
- Uses either DC current or pulse width modulation with closed loop feedback to deliver optimal system performance.

Applications

- Ventilators
- Anesthesia Delivery & Monitors
- Insufflators
- Pressure and Flow Control

Performance Characteristics

Leak Rate:	The leakage shall not exceed the following values: Internal: 5.0 sccm of Air up to 101 psi (7 bar) External: 0.5 sccm of Air up to 101 psi (7 bar)
Hysteresis:	25% of full scale current (Max)
Response time:	10ms Typical
Reliability:	100 Million Cycles, 0.95 Reliability Factor, 95% Confidence Interval

NOTE: Contact for customized configuration: eg custom calibration and electrical connections.

Manifold Dimensions

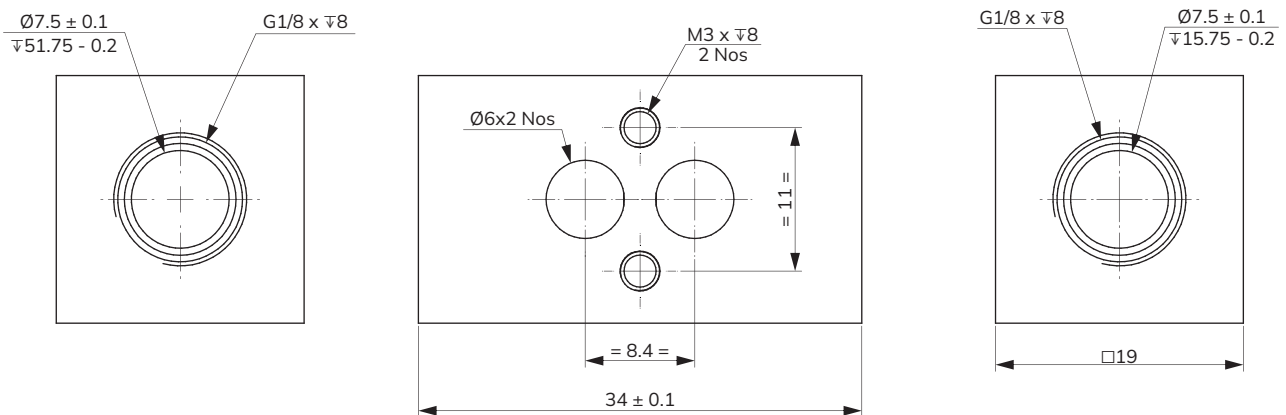

NOTE: In order to provide the best possible solution for your application, please provide the following requirements when contacting Applications Engineering:

- Media, Inlet & Outlet Pressures
- System Supply Voltage
- Minimum Required Flow Rate
- Media & Ambient Temperature Range

PROPORTIONAL SOLENOID VALVE MODEL IDENTIFICATION CHART

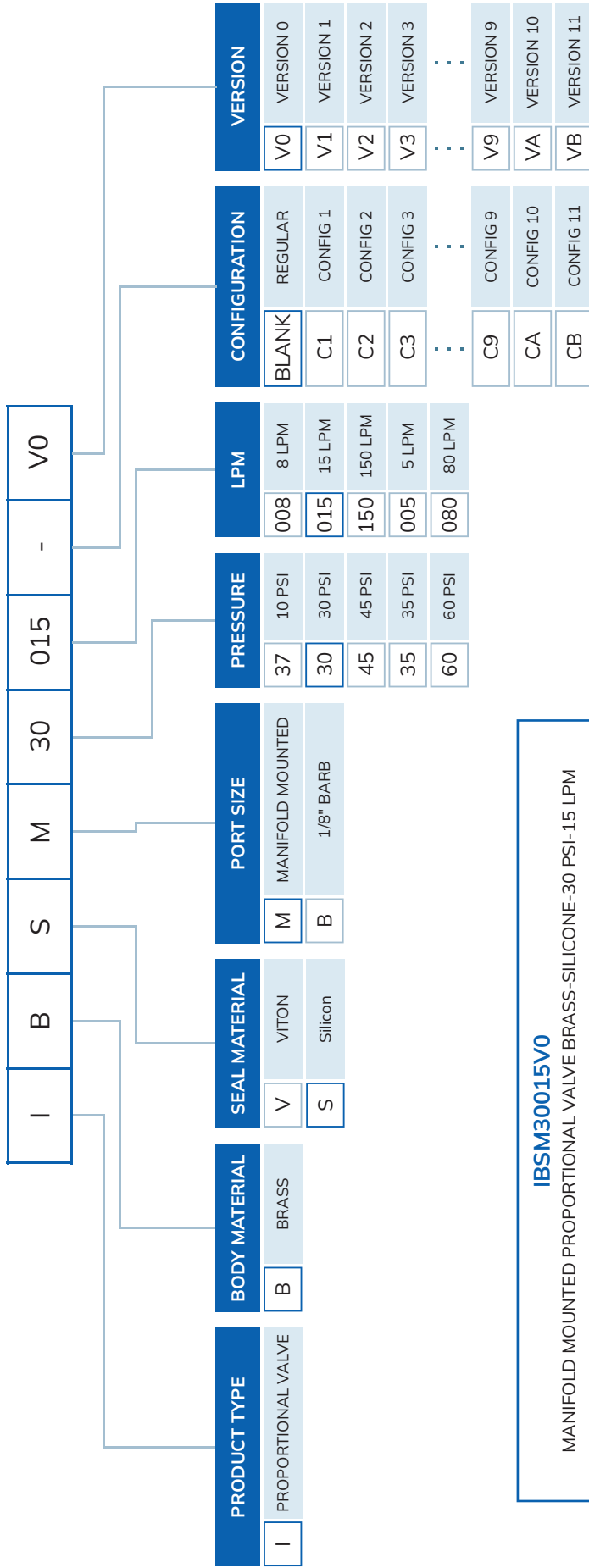

IBSM30015V0
MANIFOLD MOUNTED PROPORTIONAL VALVE BRASS-SILICONE-30 PSI-15 LPM

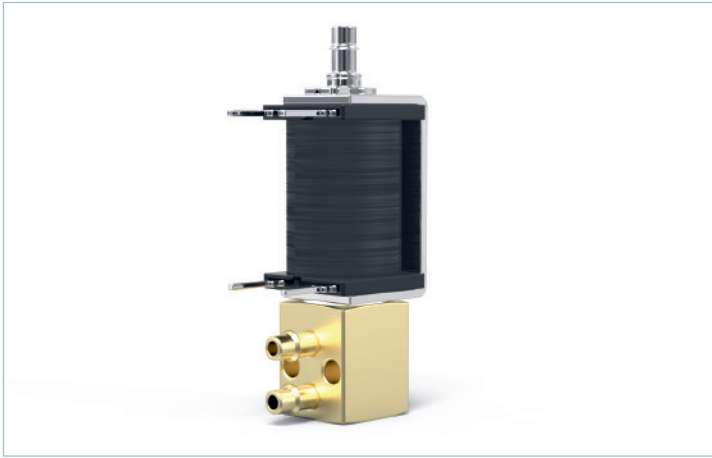

Specifications

Port :	1/8" - Barb
Seal Matrial :	Nitrile (NBR)
Media Temp :	-30°C to 90°C
Operating Voltage :	5V DC
Power Consumption :	0.5 W
Media :	Air, Gas
Main Features :	Internal Parts are in superior corrosion resistance steel, (Equivalent to ss316L) Suitable for Food Industries, Pharmaceuticals, Chemical application & Highly Corrosive Environment.

FLOW SCHEMATIC

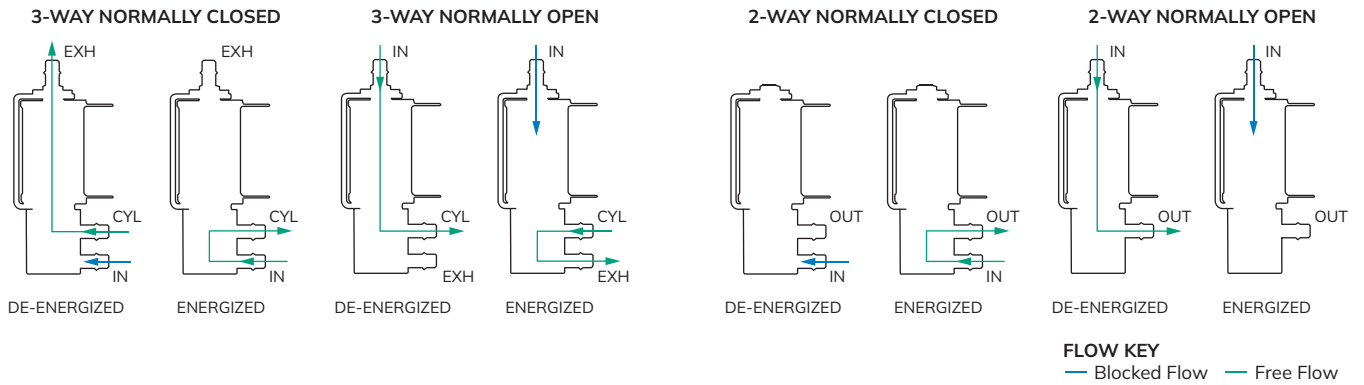

Features

- Design for extreme low wattage condition with a compact size.
- High speed response time.
- Reliable operation over 200 million cycles.
- Lubrication not essential

Applications

- Medical and Therapeutic Healthcare
- Clinical Chemistry and Analysis Equipment
- Drop-on-Demand Printing
- Environmental Instrumentation

Technical Data

Valve Model No.	Coil Model No.	Body Material	Pipe (Inch)	Orifice (mm)	Min. Operating Pressure PSI	Max. Operating Pressure PSI	Seal Material	Flow Factor Cv
TRN034JZNW013V0	R4E0AB	Brass	1/8" - Barb	1.3	0	10	Nitrile (NBR)	0.038

DIMENSIONS DRAWING (MM)

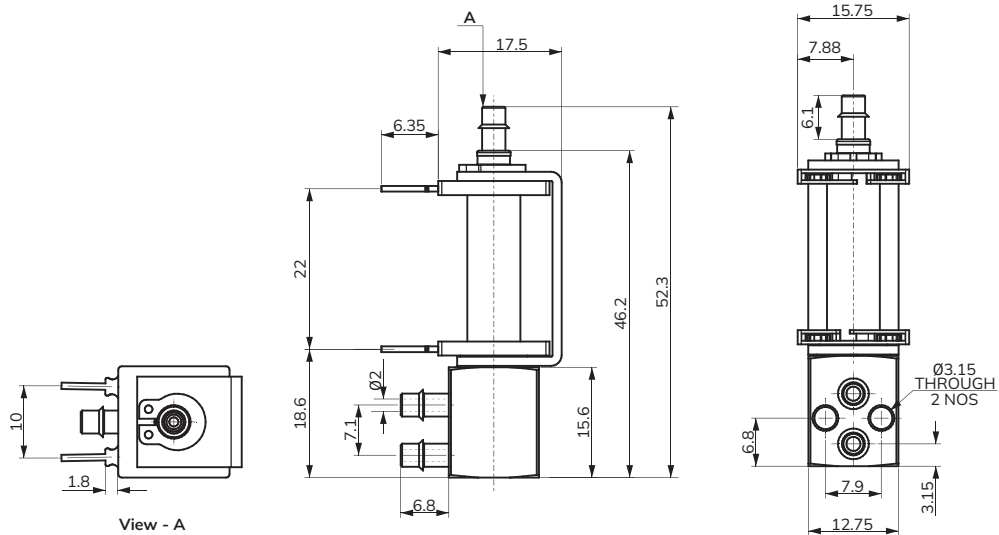

* All dimensions are approx

Scribble Note....

A series of horizontal dashed lines spanning the width of the page, intended for writing notes. The lines are evenly spaced and extend across the entire width of the page.

Our Clients



Global Presence...



Made In India



CONTACT US:

✉ sales@uflowvalve.com ☎ +91 851 109 8822 🌐 www.uflowvalve.com

📍 Uflow Automation, Ankur Industrial Complex, Survey No: 275/276, Plot No: 31, Nr. Intol Cast Pvt. Ltd. Shapar(Veraval) Dist.: Gujarat (India) - 360 024.