

# AIR PREPARATION UNITS

## FRCL MODULAR Series FRCLM1

Cat No FRCLM1 - 01 - C

### FILTER REGULATOR COMBINATION - LUBRICATOR, MODULAR - 1/4, 3/8, 1/2, 3/4, 1"

Individual Filter- Regulator combination & Lubricator units easily removable / mountable without disturbing the pipe line

#### Features

- Modular type for easy and fast maintenance
- Suitable for wall mounting
- Filter
  - Bronze filtering element
  - Separator and shield for efficient moisture separation
  - Press type manual drain for easy operation
- Regulator
  - Diaphragm operated, relieving type
  - Pressure compensated by balanced poppet
  - Flow compensated ( with venturi ) in models FRCLM14, FRCLM15 and FRCLM17 for faster response
  - Non raising ' Press to lock ' adjusting knob for locking at any set pressure
- Lubricator
  - Fog / Mist type Lubricator
  - Fine adjustment of lubrication
  - Lubrication proportional to flow
- Steel bowl guard, bayonet type on FRCLM14, FRCLM15 & FRCLM17 models and threaded type on FRCLM13 model
- Good flow and regulating characteristics



#### Technical Specifications

Model	FRCLM 13	FRCLM 14	FRCLM 15	FRCLM 17	FRCLM 17
Medium	Compressed air				
Port size	G1/4	G3/8	G1/2	G3/4	G1
Pressure gauge port size	G1/8	G1/8	G1/8	G1/4	G1/4
Flow rate <sup>®</sup> (lts / min)	500	1250	2800	3500	4000
Maximum supply pressure (bar)	10				
Regulating pressure range <sup>#</sup> (bar)	0.2 - 2, 0.2 - 4, 0.5 - 7, 0.5 - 10 (Standard)				
Ambient / Medium temperature	5° - 50° C				
Filtration <sup>#</sup> (µm)	1, 5, 25, 40 (standard), 50, 100				
Min operating flow (lts / min)	12	40	45	50	50
Bowl capacity FRC (ml) (at maximum condensate level)	9	32	44	165	165
Bowl capacity Lubricator (ml) (at maximum oil level)	20	57	152	200	200
Recommended oil	ISO VG 32 (Servo System 32)				
Bowl material	Polycarbonate				
Installation	Vertical (as shown in the picture)				
Materials of construction	Aluminium, Bronze, Brass, Steel, Acetal, Polycarbonate, SS, Nitrile				
Optional accessories *	Pressure gauge				
Weight (Kg)	0.63	1.15	2.27	4.18	4.07

<sup>®</sup> Supply pressure 7 bar , Set pressure 6 bar , Pressure drop Δp = 1bar ( For standard models )

<sup>#</sup> For details see " How to order "

<sup>\*</sup> For details refer optional accessories Cat No APA - 01 - C

# AIR PREPARATION UNITS

## FRCL MODULAR Series FRCLM1

Cat No FRCLM1 - 01 - C

Model FRCLM1361, FRCLM1462, FRCLM1563

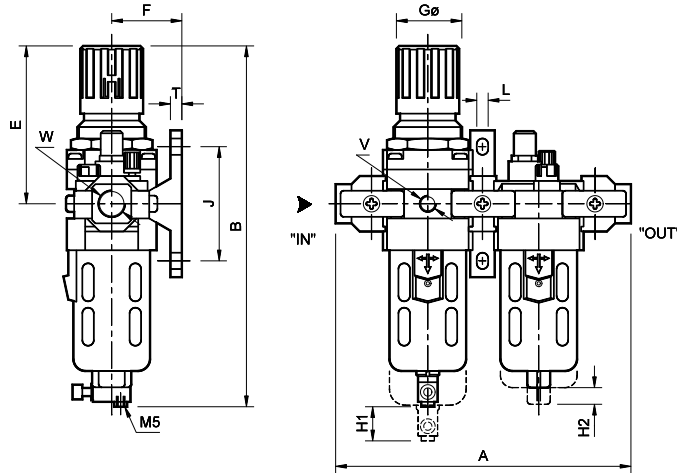

Model FRCLM1764, FRCLM1765

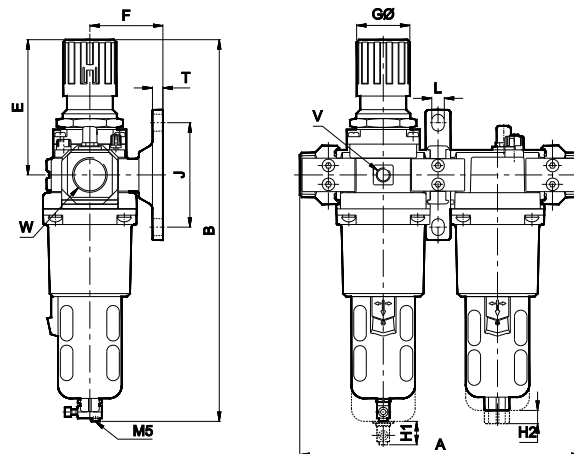

Model	W	V	A	B	E	F	GØ	J	L	T	H1	H2
FRCLM13	G1/4	G1/8	146	170	68	35	28	50	7	7	50	35
FRCLM14	G3/8	G1/8	182	220	95	45	40	70	7	7	55	45
FRCLM15	G1/2	G1/8	220	280	125	55	51	90	9	9	80	45
FRCLM17	G3/4	G1/4	270	370	130	70	51	100	12	10	80	45
FRCLM17	G1	G1/4	270	370	130	70	51	100	12	10	80	45

### Precautions

1. Note the direction of flow before installation and connect piping accordingly.
2. Flush pipings for dirt, dust, rust and other foreign particles.
3. Install in clean atmosphere.
4. Nipples of taper threads ( R ) to be used with teflon tape. Ensure teflon tape doesnot enter the unit during tightening. Nipples of straight threads ( G ) to be used with sealing washer.
5. Polycarbonate bowls may get damaged and possibly fail if exposed to synthetic oils, thinner, solvents, trichloroethylene, kerosene or other aromatic hydrocarbons.

### Pressure Setting

Pull the knob and adjust by turning the knob clockwise to increase the pressure. Push the knob back to its locked position. ( Turning the knob counter clockwise will reduce the pressure )

# AIR PREPARATION UNITS

## FRCL MODULAR Series FRCLM1

Cat No FRCLM1 - 01 - C

### Flow Graphs

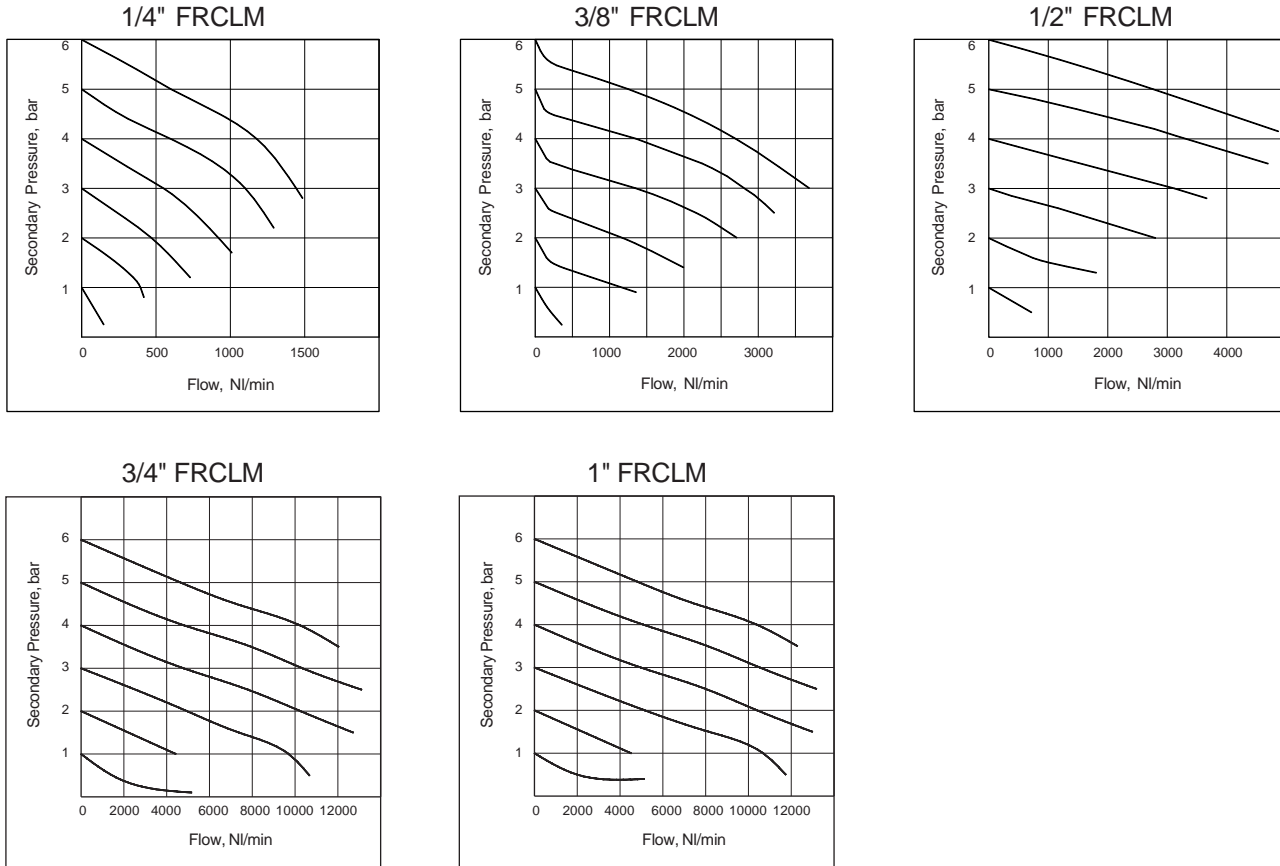

Flow graphs are for 40µm filtrations only

### How To Order

**FRCLM1**

Body & Port size	
361	G1/4
462	G3/8
563	G1/2
764	G3/4
765	G1

Filtration in µm	
0	- 1
1	- 5
2	- 25
3	- 40 (Standard)
4	- 50
5	- 100

Pressure range	
1	0.2 - 2 bar
2	0.2 - 4 bar
3	0.5 - 7 bar
4	0.5 - 10 bar (Standard)

**Ordering example** : Filter Regulator Combination and Lubricator Modular - 3/8 size ( with G3/8 port ) with 5µm Filter and pressure range 0.5 - 7 bar : Ordering No : FRCLM 146213.

If ordered as 3/8 FRCLM, our standard model FRCLM 146234, with 40µm Filter and pressure range 0.5 - 10 bar will be supplied.